



Design Considerations

- Area Required
- Slope
- Water Availability
- Aesthetics
- Environmental Side-effects

Description

Wet ponds (a.k.a. stormwater ponds, retention ponds, wet extended detention ponds) are constructed basins that have a permanent pool of water throughout the year (or at least throughout the wet season) and differ from constructed wetlands primarily in having a greater average depth. Ponds treat incoming stormwater runoff by settling and biological uptake. The primary removal mechanism is settling as stormwater runoff resides in this pool, but pollutant uptake, particularly of nutrients, also occurs to some degree through biological activity in the pond. Wet ponds are among the most widely used stormwater practices. While there are several different versions of the wet pond design, the most common modification is the extended detention wet pond, where storage is provided above the permanent pool in order to detain stormwater runoff and promote settling. The schematic diagram is of an on-line pond that includes detention for larger events, but this is not required in all areas of the state.

California Experience

Caltrans constructed a wet pond in northern San Diego County (I-5 and La Costa Blvd.). Largest issues at this site were related to vector control, vegetation management, and concern that endangered species would become resident and hinder maintenance activities.

Advantages

- If properly designed, constructed and maintained, wet basins can provide substantial aesthetic/recreational value and wildlife and wetlands habitat.
- Ponds are often viewed as a public amenity when integrated into a park setting.

Targeted Constituents

<input checked="" type="checkbox"/>	Sediment	■
<input checked="" type="checkbox"/>	Nutrients	▲
<input checked="" type="checkbox"/>	Trash	■
<input checked="" type="checkbox"/>	Metals	■
<input checked="" type="checkbox"/>	Bacteria	■
<input checked="" type="checkbox"/>	Oil and Grease	■
<input checked="" type="checkbox"/>	Organics	■

Legend (*Removal Effectiveness*)

- Low
- High
- ▲ Medium



- Due to the presence of the permanent wet pool, properly designed and maintained wet basins can provide significant water quality improvement across a relatively broad spectrum of constituents including dissolved nutrients.
- Widespread application with sufficient capture volume can provide significant control of channel erosion and enlargement caused by changes to flow frequency relationships resulting from the increase of impervious cover in a watershed.

Limitations

- Some concern about safety when constructed where there is public access.
- Mosquito and midge breeding is likely to occur in ponds.
- Cannot be placed on steep unstable slopes.
- Need for base flow or supplemental water if water level is to be maintained.
- Require a relatively large footprint
- Depending on volume and depth, pond designs may require approval from the State Division of Safety of Dams

Design and Sizing Guidelines

- Capture volume determined by local requirements or sized to treat 85% of the annual runoff volume.
- Use a draw down time of 48 hours in most areas of California. Draw down times in excess of 48 hours may result in vector breeding, and should be used only after coordination with local vector control authorities. Draw down times of less than 48 hours should be limited to BMP drainage areas with coarse soils that readily settle and to watersheds where warming may be detrimental to downstream fisheries.
- Permanent pool volume equal to twice the water quality volume.
- Water depth not to exceed about 8 feet.
- Wetland vegetation occupying no more than 25% of surface area.
- Include energy dissipation in the inlet design and a sediment forebay to reduce resuspension of accumulated sediment and facilitate maintenance.
- A maintenance ramp should be included in the design to facilitate access to the forebay for maintenance activities and for vector surveillance and control.
- To facilitate vector surveillance and control activities, road access should be provided along at least one side of BMPs that are seven meters or less in width. Those BMPs that have shoreline-to-shoreline distances in excess of seven meters should have perimeter road access on both sides or be designed such that no parcel of water is greater than seven meters from the road.

Construction/Inspection Considerations

- In areas with porous soils an impermeable liner may be required to maintain an adequate permanent pool level.
- Outlet structures and piping should be installed with collars to prevent water from seeping through the fill and causing structural failure.
- Inspect facility after first large storm to determine whether the desired residence time has been achieved.

Performance

The observed pollutant removal of a wet pond is highly dependent on two factors: the volume of the permanent pool relative to the amount of runoff from the typical event in the area and the quality of the base flow that sustains the permanent pool. A recent study (Caltrans, 2002) has documented that if the permanent pool is much larger than the volume of runoff from an average event, then displacement of the permanent pool by the wet weather flow is the primary process. A statistical comparison of the wet pond discharge quality during dry and wet weather shows that they are not significantly different. Consequently, there is a relatively constant discharge quality during storms that is the same as the concentrations observed in the pond during ambient (dry weather) conditions. Consequently, for most constituents the performance of the pond is better characterized by the average effluent concentration, rather than the “percent reduction,” which has been the conventional measure of performance. Since the effluent quality is essentially constant, the percent reduction observed is mainly a function of the influent concentrations observed at a particular site.

The dry and wet weather discharge quality is, therefore, related to the quality of the base flow that sustains the permanent pool and of the transformations that occur to those constituents during their residence in the basin. One could potentially expect a wide range of effluent concentrations at different locations even if the wet ponds were designed according to the same guidelines, if the quality of the base flow differed significantly. This may explain the wide range of concentration reductions reported in various studies.

Concentrations of nutrients in base flow may be substantially higher than in urban stormwater runoff. Even though these concentrations may be substantially reduced during the residence time of the base flow in the pond, when this water is displaced by wet weather flows, concentrations may still be quite elevated compared to the levels that promote eutrophication in surface water systems. Consequently comparing influent and effluent nutrient concentrations during wet weather can make the performance seem highly variable.

Relatively small perennial flows may often substantially exceed the wet weather flow treated. Consequently, one should also consider the load reduction observed under ambient conditions when assessing the potential benefit to the receiving water.

Siting Criteria

Wet ponds are a widely applicable stormwater management practice and can be used over a broad range of storm frequencies and sizes, drainage areas and land use types. Although they have limited applicability in highly urbanized settings and in arid climates, they have few other restrictions. Wet basins may be constructed on- or off-line and can be sited at feasible locations along established drainage ways with consistent base flow. An off-line design is preferred. Wet basins are often utilized in smaller sub-watersheds and are particularly appropriate in areas with residential land

uses or other areas where high nutrient loads are considered to be potential problems (e.g., golf courses).

Ponds do not consume a large area (typically 2–3 percent of the contributing drainage area); however, these facilities are generally large. Other practices, such as filters or swales, may be "squeezed" into relatively unusable land, but ponds need a relatively large continuous area. Wet basins are typically used in drainage basins of more than ten acres and less than one square mile (Schueler et al., 1992). Emphasis can be placed in siting wet basins in areas where the pond can also function as an aesthetic amenity or in conjunction with other stormwater management functions.

Wet basin application is appropriate in the following settings: (1) where there is a need to achieve a reasonably high level of dissolved contaminant removal and/or sediment capture; (2) in small to medium-sized regional tributary areas with available open space and drainage areas greater than about 10 ha (25 ac.); (3) where base flow rates or other channel flow sources are relatively consistent year-round; (4) in residential settings where aesthetic and wildlife habitat benefits can be appreciated and maintenance activities are likely to be consistently undertaken.

Traditional wet extended detention ponds can be applied in most regions of the United States, with the exception of arid climates. In arid regions, it is difficult to justify the supplemental water needed to maintain a permanent pool because of the scarcity of water. Even in semi-arid Austin, Texas, one study found that 2.6 acre-feet per year of supplemental water was needed to maintain a permanent pool of only 0.29 acre-feet (Saunders and Gilroy, 1997). Seasonal wet ponds (i.e., ponds that maintain a permanent pool only during the wet season) may prove effective in areas with distinct wet and dry seasons; however, this configuration has not been extensively evaluated.

Wet ponds may pose a risk to cold water systems because of their potential for stream warming. When water remains in the permanent pool, it is heated by the sun. A study in Prince George's County, Maryland, found that stormwater wet ponds heat stormwater by about 9°F from the inlet to the outlet (Galli, 1990).

Additional Design Guidelines

Specific designs may vary considerably, depending on site constraints or preferences of the designer or community. There are several variations of the wet pond design, including constructed wetlands, and wet extended detention ponds. Some of these design alternatives are intended to make the practice adaptable to various sites and to account for regional constraints and opportunities. In conventional wet ponds, the open water area comprises 50% or more of the total surface area of the pond. The permanent pool should be no deeper than 2.5 m (8 feet) and should average 1.2 – 2 m (4-6 feet) deep. The greater depth of this configuration helps limit the extent of the vegetation to an aquatic bench around the perimeter of the pond with a nominal depth of about 1 foot and variable width. This shallow bench also protects the banks from erosion, enhances habitat and aesthetic values, and reduces the drowning hazard.

The wet extended detention pond combines the treatment concepts of the dry extended detention pond and the wet pond. In this design, the water quality volume is detained above the permanent pool and released over 24 hours. In addition to increasing the residence time, which improves pollutant removal, this design also attenuates peak runoff rates. Consequently, this design alternative is recommended.

Pretreatment incorporates design features that help to settle out coarse sediment particles. By removing these particles from runoff before they reach the large permanent pool, the maintenance burden of the pond is reduced. In ponds, pretreatment is achieved with a sediment forebay. A sediment forebay is a small pool (typically about 10 percent of the volume of the permanent pool). Coarse particles remain trapped in the forebay, and maintenance is performed on this smaller pool, eliminating the need to dredge the entire pond.

There are a variety of sizing criteria for determining the volume of the permanent pool, mostly related to the water quality volume (i.e., the volume of water treated for pollutant removal) or the average storm size in a particular area. In addition, several theoretical approaches to determination of permanent pool volume have been developed. However, there is little empirical evidence to support these designs. Consequently, a simplified method (i.e., permanent pool volume equal to twice the water quality volume) is recommended.

Other design features do not increase the volume of a pond, but can increase the amount of time stormwater remains in the device and eliminate short-circuiting. Ponds should always be designed with a length-to-width ratio of at least 1.5:1, where feasible. In addition, the design should incorporate features to lengthen the flow path through the pond, such as underwater berms designed to create a longer route through the pond. Combining these two measures helps ensure that the entire pond volume is used to treat stormwater. Wet ponds with greater amounts of vegetation often have channels through the vegetated areas and contain dead areas where stormwater is restricted from mixing with the entire permanent pool, which can lead to less pollutant removal. Consequently, a pond with open water comprising about 75% of the surface area is preferred.

Design features are also incorporated to ease maintenance of both the forebay and the main pool of ponds. Ponds should be designed with a maintenance access to the forebay to ease this relatively routine (every 5–7 year) maintenance activity. In addition, ponds should generally have a drain to draw down the pond for vegetation harvesting or the more infrequent dredging of the main cell of the pond.

Cold climates present many challenges to designers of wet ponds. The spring snowmelt may have a high pollutant load and a large volume to be treated. In addition, cold winters may cause freezing of the permanent pool or freezing at inlets and outlets. Finally, high salt concentrations in runoff resulting from road salting, and sediment loads from road sanding, may impact pond vegetation as well as reduce the storage and treatment capacity of the pond.

One option to deal with high pollutant loads and runoff volumes during the spring snowmelt is the use of a seasonally operated pond to capture snowmelt during the winter and retain the permanent pool during warmer seasons. In this option, proposed by Oberts (1994), the pond has two water quality outlets, both equipped with gate valves. In the summer, the lower outlet is closed. During the fall and throughout the winter, the lower outlet is opened to draw down the permanent pool. As the spring melt begins, the lower outlet is closed to provide detention for the melt event. The manipulation of this system requires some labor and vigilance; a careful maintenance agreement should be confirmed.

Several other modifications may help to improve the performance of ponds in cold climates. Designers should consider planting the pond with salt-tolerant vegetation if the facility receives road runoff. In order to counteract the effects of freezing on inlet and outlet structures, the use of inlet and outlet structures that are resistant to frost, including weirs and larger diameter pipes, may be

useful. Designing structures on-line, with a continuous flow of water through the pond, will also help prevent freezing of these structures. Finally, since freezing of the permanent pool can reduce the effectiveness of pond systems, it is important to incorporate extended detention into the design to retain usable treatment area above the permanent pool when it is frozen.

Summary of Design Recommendations

- (1) **Facility Sizing** – The basin should be sized to hold the permanent pool as well as the required water quality volume. The volume of the permanent pool should equal twice the water quality volume.
- (2) **Pond Configuration** - The wet basin should be configured as a two stage facility with a sediment forebay and a main pool. The basins should be wedge-shaped, narrowest at the inlet and widest at the outlet. The minimum length to width ratio should be 1.5 where feasible. The perimeter of all permanent pool areas with depths of 4.0 feet or greater should be surrounded by an aquatic bench. This bench should extend inward 5-10 feet from the perimeter of the permanent pool and should be no more than 18 inches below normal depth. The area of the bench should not exceed about 25% of pond surface. The depth in the center of the basin should be 4 – 8 feet deep to prevent vegetation from encroaching on the pond open water surface.
- (3) **Pond Side Slopes** - Side slopes of the basin should be 3:1 (H:V) or flatter for grass stabilized slopes. Slopes steeper than 3:1 should be stabilized with an appropriate slope stabilization practice.
- (4) **Sediment Forebay** - A sediment forebay should be used to isolate gross sediments as they enter the facility and to simplify sediment removal. The sediment forebay should consist of a separate cell formed by an earthen berm, gabion, or loose riprap wall. The forebay should be sized to contain 15 to 25% of the permanent pool volume and should be at least 3 feet deep. Exit velocities from the forebay should not be erosive. Direct maintenance access should be provided to the forebay. The bottom of the forebay may be hardened (concrete) to make sediment removal easier. A fixed vertical sediment depth marker should be installed in the forebay to measure sediment accumulation.
- (5) **Outflow Structure** - Figure 2 presents a schematic representation of suggested outflow structures. The outlet structure should be designed to drain the water quality volume over 24 hours with the orifice sized according to the equation presented in the Extended Detention Basin fact sheet. The facility should have a separate drain pipe with a manual valve that can completely or partially drain the pond for maintenance purposes. To allow for possible sediment accumulation, the submerged end of the pipe should be protected, and the drain pipe should be sized to drain the pond within 24 hours. The valve should be located at a point where it can be operated in a safe and convenient manner.

For on-line facilities, the principal and emergency spillways must be sized to provide 1.0 foot of freeboard during the 25-year event and to safely pass the 100-year flood. The embankment should be designed in accordance with all relevant specifications for small dams.

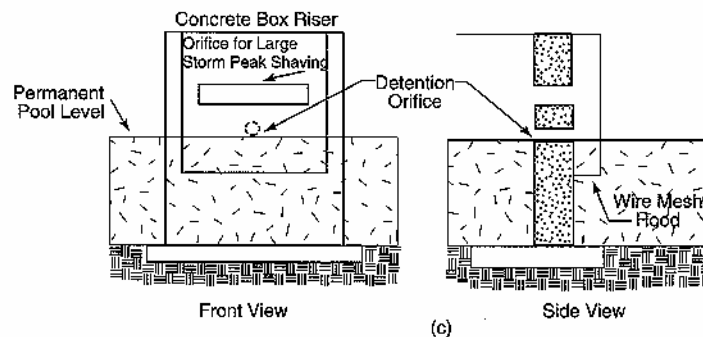
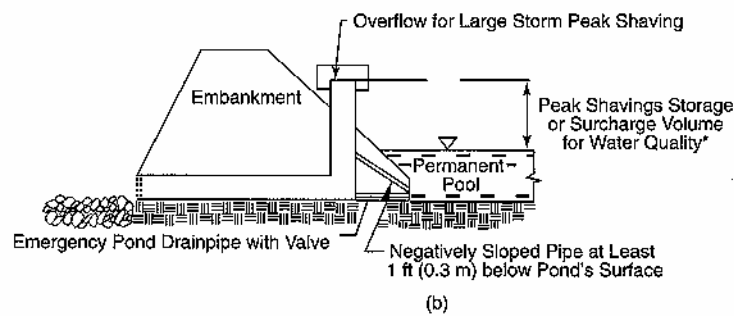
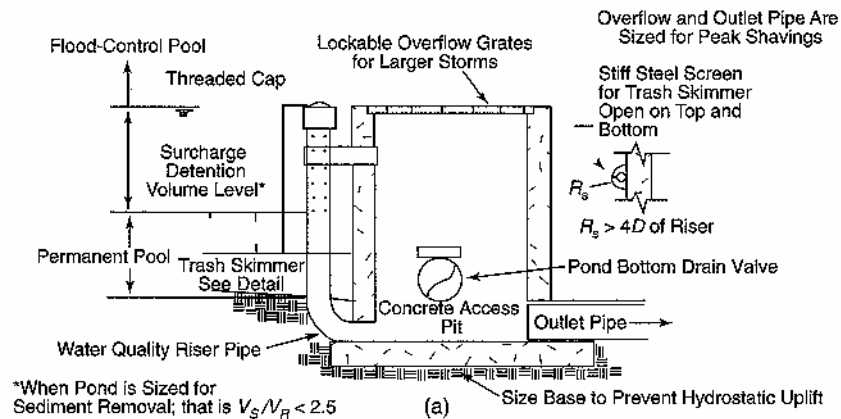

- (6) **Splitter Box** - When the pond is designed as an off-line facility, a splitter structure is used to isolate the water quality volume. The splitter box, or other flow diverting approach, should be designed to convey the 25-year event while providing at least 1.0 foot of freeboard along pond side slopes.
- (7) **Vegetation** - A plan should be prepared that indicates how aquatic and terrestrial areas will be vegetatively stabilized. Wetland vegetation elements should be placed along the aquatic bench or in the shallow portions of the permanent pool. The optimal elevation for planting of wetland vegetation is within 6 inches vertically of the normal pool elevation. A list of some wetland vegetation native to California is presented in Table 1.

Botanical Name	Common Name
BACCHARIS SALICIFOLIA	MULE FAT
FRANKENIA GRANDIFOLIA	HEATH
SALIX GOODINGII	BLACK WILLOW
SALIX LASIOLEPIS	ARROYO WILLOW
SAMUCUS MEXICANUS	MEXICAN ELDERBERRY
HAPLOPAPPUS VENETUS	COAST GOLDENBRUSH
DISTICHIS SPICATA	SALT GRASS
LIMONIUM CALIFORNICUM	COASTAL STATICE
ATRIPLEX LENTIFORMIS	COASTAL QUAIL BUSH
BACCHARIS PILULARIS	CHAPARRAL BROOM
MIMULUS LONGIFLORUS	MONKEY FLOWER
SCIRPUS CALIFORNICUS	BULRUSH
SCIRPUS ROBUSTUS	BULRUSH
TYPHA LATIFOLIA	BROADLEAF CATTAIL
JUNCUS ACUTUS	RUSH

Maintenance

The amount of maintenance required for a wet pond is highly dependent on local regulatory agencies, particular health and vector control agencies. These agencies are often extremely concerned about the potential for mosquito breeding that may occur in the permanent pool. Even though mosquito fish (*Gambusia affinis*) were introduced into a wet pond constructed by Caltrans in the San Diego area, mosquito breeding was routinely observed during inspections. In addition, the vegetation at this site became sufficiently dense on the bench around the edge of the pool that mosquito fish were unable to enter this area to feed upon the mosquito larvae. The vegetation at this site was particularly vigorous because of the high nutrient concentrations in the perennial base flow (15.5 mg/L NO₃-N) and the mild climate, which permitted growth year round. Consequently, the vector control agency required an annual harvest of vegetation to address this situation. This harvest can be very expensive.

On the other hand, routine harvesting may increase nutrient removal and prevent the export of these constituents from dead and dying plants falling in the water. A previous study (Faulkner and Richardson, 1991) documented dramatic reductions in nutrient removal after the first several years of operation and related it to the vegetation achieving a maximum density. That content then decreases through the growth season, as the total biomass increases. In effect, the total amount of

nutrients/m² of wetland remains essentially the same from June through September, when the plants start to put the P back into the rhizomes. Therefore harvesting should occur between June and September. Research also suggests that harvesting only the foliage is less effective, since a very small percentage of the removed nutrients is taken out with harvesting.

Since wet ponds are often selected for their aesthetic considerations as well as pollutant removal, they are often sited in areas of high visibility. Consequently, floating litter and debris are removed more frequently than would be required simply to support proper functioning of the pond and outlet. This is one of the primary maintenance activities performed at the Central Market Pond located in Austin, Texas. In this type of setting, vegetation management in the area surrounding the pond can also contribute substantially to the overall maintenance requirements.

One normally thinks of sediment removal as one of the typical activities performed at stormwater BMPs. This activity does not normally constitute one of the major activities on an annual basis. At the concentrations of TSS observed in urban runoff from stable watersheds, sediment removal may only be required every 20 years or so. Because this activity is performed so infrequently, accurate costs for this activity are lacking.

In addition to regular maintenance activities needed to maintain the function of wet ponds, some design features can be incorporated to ease the maintenance burden. In wet ponds, maintenance reduction features include techniques to reduce the amount of maintenance needed, as well as techniques to make regular maintenance activities easier.

One potential maintenance concern in wet ponds is clogging of the outlet. Ponds should be designed with a non-clogging outlet such as a reverse-slope pipe, or a weir outlet with a trash rack. A reverse-slope pipe draws from below the permanent pool extending in a reverse angle up to the riser and establishes the water elevation of the permanent pool. Because these outlets draw water from below the level of the permanent pool, they are less likely to be clogged by floating debris.

Typical maintenance activities and frequencies include:

- Schedule semiannual inspections for burrows, sediment accumulation, structural integrity of the outlet, and litter accumulation.
- Remove accumulated trash and debris in the basin at the middle and end of the wet season. The frequency of this activity may be altered to meet specific site conditions and aesthetic considerations.
- Where permitted by the Department of Fish and Game or other agency regulations, stock wet ponds/constructed wetlands regularly with mosquito fish (*Gambusia spp.*) to enhance natural mosquito and midge control.
- Introduce mosquito fish and maintain vegetation to assist their movements to control mosquitoes, as well as to provide access for vector inspectors. An annual vegetation harvest in summer appears to be optimum, in that it is after the bird breeding season, mosquito fish can provide the needed control until vegetation reaches late summer density, and there is time for re-growth for runoff treatment purposes before the wet season. In certain cases, more frequent plant harvesting may be required by local vector control agencies.

- Maintain emergent and perimeter shoreline vegetation as well as site and road access to facilitate vector surveillance and control activities.
- Remove accumulated sediment in the forebay and regrade about every 5-7 years or when the accumulated sediment volume exceeds 10 percent of the basin volume. Sediment removal may not be required in the main pool area for as long as 20 years.

Cost

Construction Cost

Wet ponds can be relatively inexpensive stormwater practices; however, the construction costs associated with these facilities vary considerably. Much of this variability can be attributed to the degree to which the existing topography will support a wet pond, the complexity and amount of concrete required for the outlet structure, and whether it is installed as part of new construction or implemented as a retrofit of existing storm drain system.

A recent study (Brown and Schueler, 1997) estimated the cost of a variety of stormwater management practices. The study resulted in the following cost equation, adjusting for inflation:

$$C = 24.5V^{0.705}$$

where:

C = Construction, design and permitting cost;

V = Volume in the pond to include the 10-year storm (ft³).

Using this equation, typical construction costs are:

\$45,700 for a 1 acre-foot facility

\$232,000 for a 10 acre-foot facility

\$1,170,000 for a 100 acre-foot facility

In contrast, Caltrans (2002) reported spending over \$448,000 for a pond with a total permanent pool plus water quality volume of only 1036 m³ (0.8 ac.-ft.), while the City of Austin spent \$584,000 (including design) for a pond with a permanent pool volume of 3,100 m³ (2.5 ac.-ft.). The large discrepancies between the costs of these actual facilities and the model developed by Brown and Schueler indicate that construction costs are highly site specific, depending on topography, soils, subsurface conditions, the local labor, rate and other considerations.

Maintenance Cost

For ponds, the annual cost of routine maintenance has typically been estimated at about 3 to 5 percent of the construction cost; however, the published literature is almost totally devoid of actual maintenance costs. Since ponds are long-lived facilities (typically longer than 20 years), major maintenance activities are unlikely to occur during a relatively short study.

Caltrans (2002) estimated annual maintenance costs of \$17,000 based on three years of monitoring of a pond treating runoff from 1.7 ha. Almost all the activities are associated with the annual vegetation harvest for vector control. Total cost at this site falls within the 3-5% range reported

above; however, the construction costs were much higher than those estimated by Brown and Schueler (1997). The City of Austin has been reimbursing a developer about \$25,000/yr for wet pond maintenance at a site located at a very visible location. Maintenance costs are mainly the result of vegetation management and litter removal. On the other hand, King County estimates annual maintenance costs at about \$3,000 per pond; however, this cost likely does not include annual extensive vegetation removal. Consequently, maintenance costs may vary considerably at sites in California depending on the aggressiveness of the vegetation management in that area and the frequency of litter removal.

References and Sources of Additional Information

Amalfi, F.A., R. Kadlec, R.L. Knight, G. O'Meara, W.K. Reisen, W.E. Walton, and R. Wass. 1999. A Mosquito Control Strategy For The Tres Rios Demonstration Constructed Wetlands. CH2M Hill, Tempe, AZ, 140 pp.

Bannerman, R., and R. Dodds. 1992. Unpublished data. Bureau of Water Resources Management, Wisconsin Department of Natural Resources, Madison, WI.

Borden, R. C., J.L. Dorn, J.B. Stillman, and S.K. Liehr; 1996. *Evaluation of Ponds and Wetlands for Protection of Public Water Supplies*. Draft Report. Water Resources Research Institute of the University of North Carolina, Department of Civil Engineering, North Carolina State University, Raleigh, NC.

Brown, W., and T. Schueler. 1997. *The Economics of Stormwater BMPs in the Mid-Atlantic Region*. Prepared for the Chesapeake Research Consortium, Edgewater, MD, by the Center for Watershed Protection; Ellicott City, MD.

Caltrans, 2002, *Proposed Final Report: BMP Retrofit Pilot Program*, California Dept. of Transportation Report CTSW-RT-01-050, and Sacramento, CA.

City of Austin, TX. 1991. *Design Guidelines for Water Quality Control Basins*. Public Works Department, Austin, TX.

City of Austin, TX. 1996. Evaluation of Non-Point Source Controls: A 319 Grant Project. Draft Water Quality Report Series, Public Works Department, Austin, TX.

Cullum, M. 1985. Stormwater Runoff Analysis at a Single Family Residential Site. Publication 85-1. University of Central Florida, Orlando, FL. pp. 247–256.

Dorman, M.E., J. Hartigan, R.F. Steg, and T. Quasebarth. 1989. *Retention, Detention and Overland Flow for Pollutant Removal From Highway Stormwater Runoff*. Vol. 1 Research Report. FHWA/RD 89/202. Federal Highway Administration, Washington, DC.

Dorothy, J.M., and K. Staker. 1990. A preliminary Survey For Mosquito Breeding In Stormwater Retention Ponds In Three Maryland Counties. Mosquito Control, Maryland Department of Agriculture, College Park, MD. 5 pp.

Driscoll, E.D. 1983. *Performance of Detention Basins for Control of Urban Runoff Quality*. Presented at the 1983 International Symposium on Urban Hydrology, Hydraulics and Sedimentation Control, University of Kentucky, Lexington, KY.

- Emmerling-Dinovo, C. 1995. Stormwater detention basins and residential locational decisions. *Water Resources Bulletin*, 31(3):515–52.
- Faulkner, S. and Richardson, C., 1991, Physical and chemical characteristics of freshwater wetland soils, in *Constructed Wetlands for Wastewater Treatment*, ed. D. Hammer, Lewis Publishers, 831 pp.
- Gain, W.S. 1996. *The Effects of Flow Path Modification on Water Quality Constituent Retention in an Urban Stormwater Detention Pond and Wetland System*. Water Resources Investigations Report 95-4297. U.S. Geological Survey, Tallahassee, FL.
- Galli, F. 1990. *Thermal Impacts Associated with Urbanization and Stormwater Best Management Practices*. Prepared for the Maryland Department of the Environment, Baltimore, MD, by the Metropolitan Council of Governments, Washington, DC.
- Glick, Roger, 2001, personal communication, City of Austin Watershed Protection Dept., Austin, TX.
- Holler, J.D. 1989. Water Quality Efficiency Of An Urban Commercial Wet Detention Stormwater Management System At Boynton Beach Mall in South Palm Beach County, FL. *Florida Scientist* 52(1):48–57.
- Holler, J.D. 1990. Nonpoint Source Phosphorous Control By A Combination Wet Detention/ Filtration Facility In Kissimmee, FL. *Florida Scientist* 53(1):28–37.
- Horner, R.R., J. Guedry, and M.H. Kortenhoff. 1990. *Improving the Cost Effectiveness of Highway Construction Site Erosion and Pollution Control*. Final Report. Washington State Transportation Commission, Olympia, WA.
- Kantrowitz .I. and W. Woodham 1995. *Efficiency of a Stormwater Detention Pond in Reducing Loads of Chemical and Physical Constituents in Urban Stream flow, Pinellas County, Florida*. Water Resources Investigations Report 94-4217. U.S. Geological Survey, Tallahassee, FL.
- Martin, E. 1988. Effectiveness of an urban runoff detention pond/wetland system. *Journal of Environmental Engineering* 114(4):810–827.
- Maryland Department of the Environment (MDE). 2000. *Maryland Stormwater Design Manual*. <http://www.mde.state.md.us/environment/wma/stormwatermanual>.
- McLean, J. 2000. Mosquitoes In Constructed Wetlands: A Management Bugaboo? In T.R. Schueler and H.K. Holland [eds.], *The Practice of Watershed Protection*. pp. 29-33. Center for Watershed Protection, Ellicott City, MD.
- Metzger, M. E., D. F. Messer, C. L. Beitia, C. M. Myers, and V. L. Kramer. 2002. The Dark Side Of Stormwater Runoff Management: Disease Vectors Associated With Structural BMPs. *Stormwater* 3(2): 24-39.
- Oberts, G.L. 1994. Performance of stormwater ponds and wetlands in winter. *Watershed Protection Techniques* 1(2):64–68.

Oberts, G.L., P.J. Wotzka, and J.A. Hartsoe. 1989. *The Water Quality Performance of Select Urban Runoff Treatment Systems*. Publication No. 590-89-062a. Prepared for the Legislative Commission on Minnesota Resources, Metropolitan Council, St. Paul, MN.

Oberts, G.L., and L. Wotzka. 1988. The water quality performance of a detention basin wetland treatment system in an urban area. In *Nonpoint Source Pollution: Economy, Policy, Management and Appropriate Technology*. American Water Resources Association, Middleburg, VA.

Occoquan Watershed Monitoring Laboratory. 1983. Metropolitan Washington Urban Runoff Project. Final Report. Prepared for the Metropolitan Washington Council of Governments, Washington, DC, by the Occoquan Watershed Monitoring Laboratory, Manassas, VA.

Ontario Ministry of the Environment. 1991. *Stormwater Quality Best Management Practices*. Marshall Macklin Monaghan Limited, Toronto, Ontario.

Protection Agency, Office of Water, Washington, DC, by the Watershed Management Institute, Ingleside, MD.

Santana, F.J., J.R. Wood, R.E. Parsons, and S.K. Chamberlain. 1994. Control Of Mosquito Breeding In Permitted Stormwater Systems. Sarasota County Mosquito Control and Southwest Florida Water Management District, Brooksville, FL., 46 pp.

Saunders, G. and M. Gilroy, 1997. *Treatment of Nonpoint Source Pollution with Wetland/Aquatic Ecosystem Best Management Practices*. Texas Water Development Board, Lower Colorado River Authority, Austin, TX.

Schueler, T. 1997a. Comparative pollutant removal capability of urban BMPs: A reanalysis. *Watershed Protection Techniques* 2(4):515–520.

Schueler, T. 1997b. Influence of groundwater on performance of stormwater ponds in Florida. *Watershed Protection Techniques* 2(4):525–528.

Urbonas, B., J. Carlson, and B. Vang. 1994. Joint Pond-Wetland System in Colorado. Denver Urban Drainage and Flood Control District, Denver, CO.

U.S. Environmental Protection Agency (USEPA). 1995. *Economic Benefits of Runoff Controls*. U.S. Environmental Protection Agency, Office of Wetlands, Oceans, and Watersheds, Washington, DC.

Watershed Management Institute (WMI). 1997. *Operation, Maintenance, and Management of Stormwater Management Systems*. Prepared for U.S. Environmental Protection Agency, Office of Water, Washington, DC, by the Watershed Management Institute, Ingleside, MD.
Water Environment Federation and ASCE, 1998, *Urban Runoff Quality Management*, WEF Manual of Practice No. 23 and ASCE Manual and Report on Engineering Practice No. 87.

Wu, J. 1989. Evaluation of Detention Basin Performance in the Piedmont Region of North Carolina. Report No. 89-248. North Carolina Water Resources Research Institute, Raleigh, NC.

Yousef, Y., M. Wanielista, and H. Harper. 1986. Design and Effectiveness of Urban Retention Basins. In *Urban Runoff Quality—Impact and Quality Enhancement Technology*. B. Urbonas and L.A. Roesner (Eds.). American Society of Civil Engineering, New York, New York. pp. 338–350.

Information Resources

- Center for Watershed Protection (CWP). 1995. *Stormwater Management Pond Design Example for Extended Detention Wet Pond*. Center for Watershed Protection, Ellicott City, MD.
- Center for Watershed Protection (CWP). 1997. *Stormwater BMP Design Supplement for Cold Climates*. Prepared for U.S. Environmental Protection Agency, Office of Wetlands, Oceans and Watersheds, Washington, DC, by the Center for Watershed Protection, Ellicott City, MD.
- Denver Urban Drainage and Flood Control District. 1992. *Urban Storm Drainage Criteria Manual—Volume 3: Best Management Practices*. Denver Urban Drainage and Flood Control District, Denver, CO.
- Galli, J. 1992. *Preliminary Analysis of the Performance and Longevity of Urban BMPs Installed in Prince George's County, Maryland*. Prince George's County, Maryland, Department of Natural Resources, Largo, MD.
- MacRae, C. 1996. Experience from Morphological Research on Canadian Streams: Is Control of the Two-Year Frequency Runoff Event the Best Basis for Stream Channel Protection? In *Effects of Watershed Development and Management on Aquatic Ecosystems*. American Society of Civil Engineers. Snowbird, UT. pp. 144–162.
- Minnesota Pollution Control Agency. 1989. *Protecting Water Quality in Urban Areas: Best Management Practices*. Minnesota Pollution Control Agency, Minneapolis, MN.
- U.S. Environmental Protection Agency (USEPA). 1993. *Guidance Specifying Management Measures for Sources of Nonpoint Pollution in Coastal Waters*. EPA-840-B-92-002. U.S. Environmental Protection Agency, Office of Water, Washington, DC.

