



Design Considerations

- Aesthetics
- Hydraulic Head

Description

Stormwater media filters are usually two-chambered including a pretreatment settling basin and a filter bed filled with sand or other absorptive filtering media. As stormwater flows into the first chamber, large particles settle out, and then finer particles and other pollutants are removed as stormwater flows through the filtering media in the second chamber. There are a number of design variations including the Austin sand filter, Delaware sand filter, and multi-chambered treatment train (MCTT).

California Experience

Caltrans constructed and monitored five Austin sand filters, two MCTTs, and one Delaware design in southern California. Pollutant removal was very similar for each of the designs; however operational and maintenance aspects were quite different. The Delaware filter and MCTT maintain permanent pools and consequently mosquito management was a critical issue, while the Austin style which is designed to empty completely between storms was less affected. Removal of the top few inches of sand was required at 3 of the Austin filters and the Delaware filter during the third year of operation; consequently, sizing of the filter bed is a critical design factor for establishing maintenance frequency.

Advantages

- Relatively high pollutant removal, especially for sediment and associated pollutants.
- Widespread application with sufficient capture volume can provide significant control of channel erosion and enlargement caused by changes to flow frequency relationships resulting from the increase of impervious cover in a watershed.

Limitations

Targeted Constituents

✓	Sediment	■
✓	Nutrients	●
✓	Trash	■
✓	Metals	■
✓	Bacteria	▲
✓	Oil and Grease	■
✓	Organics	■

Legend (Removal Effectiveness)

- Low
- High
- ▲ Medium



- More expensive to construct than many other BMPs.
- May require more maintenance than some other BMPs depending upon the sizing of the filter bed.
- Generally require more hydraulic head to operate properly (minimum 4 feet).
- High solids loads will cause the filter to clog.
- Work best for relatively small, impervious watersheds.
- Filters in residential areas can present aesthetic and safety problems if constructed with vertical concrete walls.
- Certain designs (e.g., MCTT and Delaware filter) maintain permanent sources of standing water where mosquito and midge breeding is likely to occur.

Design and Sizing Guidelines

- Capture volume determined by local requirements or sized to treat 85% of the annual runoff volume.
- Filter bed sized to discharge the capture volume over a period of 48 hours.
- Filter bed 18 inches thick above underdrain system.
- Include energy dissipation in the inlet design to reduce resuspension of accumulated sediment.
- A maintenance ramp should be included in the design to facilitate access to the sedimentation and filter basins for maintenance activities (particularly for the Austin design).
- Designs that utilize covered sedimentation and filtration basins should be accessible to vector control personnel via access doors to facilitate vector surveillance and controlling the basins if needed.

Construction/Inspection Considerations

- Tributary area should be completely stabilized before media is installed to prevent premature clogging.

Performance

The pollutant removal performance of media filters and other stormwater BMPs is generally characterized by the percent reduction in the influent load. This method implies a relationship between influent and effluent concentrations. For instance, it would be expected that a device that is reported to achieve a 75% reduction would have an effluent concentration equal to 25% of the influent concentrations. Recent work in California (Caltrans, 2002) on various sand filter designs indicates that this model for characterizing performance is inadequate. Figure 4 presents a graph relating influent and effluent TSS concentrations for the Austin full sedimentation design.

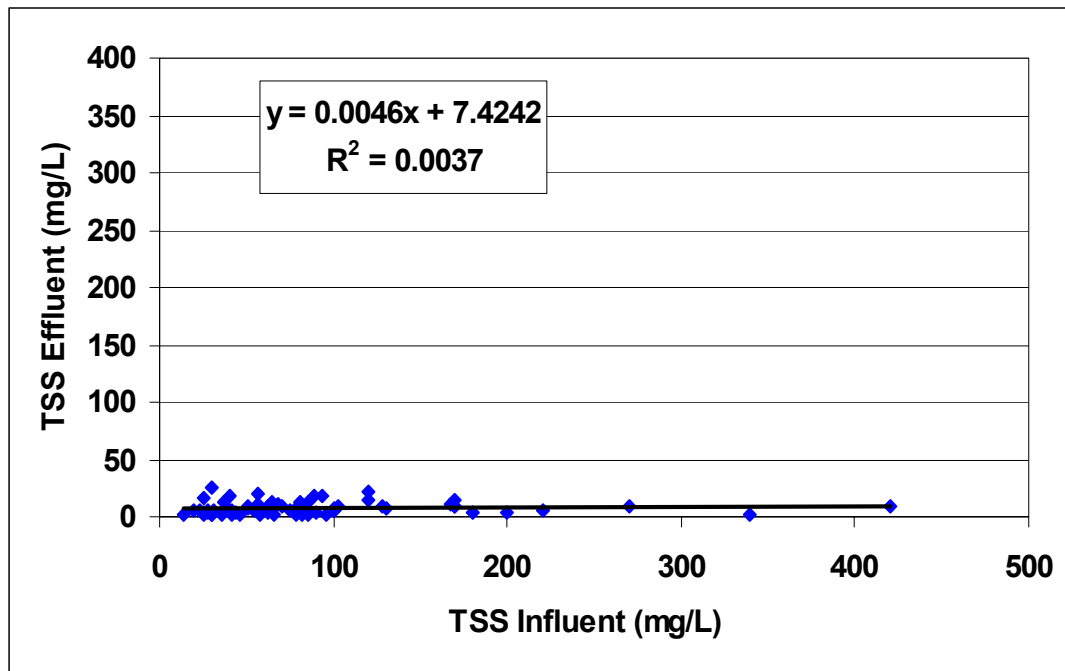

Figure 4
Comparison of Influent and Effluent Concentrations for TSS

It is clearly evident that the effluent concentration is relative constant and independent of influent concentration. Consequently, the performance is more accurately characterized by the effluent concentration, which is about 7.5 mg/L. Constant effluent concentrations also are observed for all other particle related constituents such as particulate metals (total - dissolved) and particulate phosphorus.

The small uncertainty in the estimate of the mean effluent concentration highlights the very consistent effluent quality for TSS produced by sand filters. In addition, it demonstrates that a calculated percent reduction for TSS and other constituents with similar behavior for Austin sand filters is a secondary characteristic of the device and depends primarily on the specific influent concentrations observed. The distinction between a constant effluent quality and a percent reduction is extremely important to recognize if the results are to be used to estimate effluent quality from sand filters installed at other sites with different influent concentrations or for estimating compliance with water quality standards for storms with high concentrations of particulate constituents.

If the conventionally derived removal efficiency (90%) were used to estimate the TSS concentrations in the treated runoff from storms with high influent concentrations, the estimated effluent concentration would be too high. For instance, the storm with the highest observed influent concentration (420 mg/L) would be expected to have a concentration in the treated runoff of 42 mg/L, rather than the 10 mg/L that was measured. In fact, the TSS effluent concentrations for all events with influent concentrations greater than 200 mg/L were 10 mg/L or less.

The stable effluent concentration of a sand filter under very different influent TSS concentrations implies something about the properties of the influent particle size distribution. If one assumes that

only the smallest size fraction can pass through the filter, then the similarity in effluent concentrations suggests that there is little difference in the total mass of the smallest sized particles even when the total TSS concentration varies greatly. Further, the difference in TSS concentration must then be caused by changes in the relative amount of the larger size fractions. Further research is necessary to determine the range of particle size that is effectively removed in the filter and the portion of the size fraction of suspended solids that it represents in urban stormwater.

Sand filters are effective stormwater management practices for pollutant removal. Conventional removal rates for all sand filters and organic filters are presented in Table 1. With the exception of nitrates, which are always exported from filtering systems because of the conversion of ammonia and organic nitrogen to nitrate, they perform relatively well at removing pollutants.

Table 1 Sand filter removal efficiencies (percent)

	Sand Filter (Glick et al, 1998)	Compost Filter System		Multi-Chamber Treatment Train		
		Stewart, 1992	Leif, 1999	Pitt et al., 1997	Pitt, 1996	Greb et al., 1998
TSS	89	95	85	85	83	98
TP	59	41	4	80	-	84
TN	17	-	-	-	-	-
Nitrate	-76	-34	-95	-	14	-
Metals	72-86	61-88	44-75	65-90	91-100	83-89
Bacteria	65	-	-	-	-	-

From the few studies available, it is difficult to determine if organic filters necessarily have higher removal efficiencies than sand filters. The MCTT may have high pollutant removal for some constituents, although an evaluation of these devices by the California Department of Transportation indicated no significant difference for most conventional pollutants.

In addition to the relatively high pollutant removal in media filters, these devices, when sized to capture the channel forming storm volume, are highly effective at attenuating peak flow rates and reducing channel erosion.

Siting Criteria

In general, sand filters are preferred over infiltration practices, such as infiltration trenches, when contamination of groundwater with conventional pollutants is of concern. This usually occurs in areas where underlying soils alone cannot treat runoff adequately - or ground water tables are high. In most cases, sand filters can be constructed with impermeable basin or chamber bottoms, which help to collect, treat, and release runoff to a storm drainage system or directly to surface water with no contact between contaminated runoff and groundwater. In regions where evaporation exceeds rainfall and a wet pond would be unlikely to maintain the required permanent pool, a sand filtration system can be used.

The selection of a sand filter design depends largely on the drainage area's characteristics. For example, the Washington, D.C. and Delaware sand filter systems are well suited for highly impervious areas where land available for structural controls is limited, since both are installed underground. They have been used to treat runoff from parking lots, driveways, loading docks, service stations, garages, airport runways/taxiways, and storage yards. The Austin sand filtration system is more suited for large drainage areas that have both impervious and pervious surfaces. This system is located at grade and is used to treat runoff from any urban land use.

It is challenging to use most sand filters in very flat terrain because they require a significant amount of hydraulic head (about 4 feet), to allow flow through the system. One exception is the perimeter sand filter, which can be applied with as little as 2 feet of head.

Sand filters are best applied on relatively small sites (up to 25 acres for surface sand filters and closer to 2 acres for perimeter or underground filters). Filters have been used on larger drainage areas, of up to 100 acres, but these systems can clog when they treat larger drainage areas unless adequate measures are provided to prevent clogging, such as a larger sedimentation chamber or more intensive regular maintenance.

When sand filters are designed as a stand-alone practice, they can be used on almost any soil because they can be designed so that stormwater never infiltrates into the soil or interacts with the ground water. Alternatively, sand filters can be designed as pretreatment for an infiltration practice, where soils do play a role.

Additional Design Guidelines

Pretreatment is a critical component of any stormwater management practice. In sand filters, pretreatment is achieved in the sedimentation chamber that precedes the filter bed. In this chamber, the coarsest particles settle out and thus do not reach the filter bed. Pretreatment reduces the maintenance burden of sand filters by reducing the potential for these sediments to clog the filter. When pretreatment is not provided designers should increase the size of the filter area to reduce the clogging potential. In sand filters, designers should select a medium sand as the filtering medium. A fine aggregate (ASTM C-33) that is intended for use in concrete is commonly specified.

Many guidelines recommend sizing the filter bed using Darcy's Law, which relates the velocity of fluids to the hydraulic head and the coefficient of permeability of a medium. The resulting equation, as derived by the city of Austin, Texas, (1996), is

$$A_f = WQV d / [k t (h+d)]$$

Where:

A_f = area of the filter bed (ft²);

d = depth of the filter bed (ft; usually about 1.5 feet, depending on the design);

k = coefficient of permeability of the filtering medium (ft/day);

t = time for the water quality volume to filter through the system (days; usually assumed to be 1.67 days); and

h = average water height above the sand bed (ft; assumed to be one-half of the maximum head).

Typical values for k , as assembled by CWP (1996), are shown in Table 2.

Table 2 Coefficient of permeability values for stormwater filtering practices (CWP, 1996)	
Filter Medium	Coefficient of Permeability (ft/day)
Sand	3.5
Peat/Sand	2.75
Compost	8.7

The permeability of sand shown in Table 2 is extremely conservative, but is widely used since it is incorporated in the design guidelines of the City of Austin. When the sand is initially installed, the permeability is so high (over 100 ft/d) that generally only a portion of the filter area is required to infiltrate the entire volume, especially in a “full sedimentation” Austin design where the capture volume is released to the filter basin over 24 hours.

The preceding methodology results in a filter bed area that is oversized when new and the entire water quality volume is filtered in less than a day with no significant height of water on top of the sand bed. Consequently, the following simple rule of thumb is adequate for sizing the filter area. If the filter is preceded by a sedimentation basin that releases the water quality volume (WQV) to the filter over 24 hours, then

$$A_f = WQV/18$$

If no pretreatment is provided then the filter area is calculated more conservatively as:

$$A_f = WQV/10$$

Typically, filtering practices are designed as “off-line” systems, meaning that during larger storms all runoff greater than the water quality volume is bypassed untreated using a flow splitter, which is a structure that directs larger flows to the storm drain system or to a stabilized channel. One exception is the perimeter filter; in this design, all flows enter the system, but larger flows overflow to an outlet chamber and are not treated by the practice.

The Austin design variations are preferred where there is sufficient space, because they lack a permanent pool, which eliminates vector concerns. Design details of this variation are summarized below.

Summary of Design Recommendations

- (1) Capture Volume - The facility should be sized to capture the required water quality volume, preferably in a separate pretreatment sedimentation basin.

- (2) Basin Geometry – The water depth in the sedimentation basin when full should be at least 2 feet and no greater than 10 feet. A fixed vertical sediment depth marker should be installed in the sedimentation basin to indicate when 20% of the basin volume has been lost because of sediment accumulation. When a pretreatment sedimentation basin is provided the minimum average surface area for the sand filter (A_f) is calculated from the following equation:

$$A_f = WQV/18$$

If no pretreatment is provided then the filter area is calculated as:

$$A_f = WQV/10$$

- (3) Sand and Gravel Configuration - The sand filter is constructed with 18 inches of sand overlying 6 inches of gravel. The sand and gravel media are separated by permeable geotextile fabric and the gravel layer is situated on geotextile fabric. Four-inch perforated PVC pipe is used to drain captured flows from the gravel layer. A minimum of 2 inches of gravel must cover the top surface of the PVC pipe. Figure 5 presents a schematic representation of a standard sand bed profile.
- (4) Sand Properties – The sand grain size distribution should be comparable to that of “washed concrete sand,” as specified for fine aggregate in ASTM C-33.
- (5) Underdrain Pipe Configuration – In an Austin filter, the underdrain piping should consist of a main collector pipe and two or more lateral branch pipes, each with a minimum diameter of 4 inches. The pipes should have a minimum slope of 1% (1/8 inch per foot) and the laterals should be spaced at intervals of no more than 10 feet. There should be no fewer than two lateral branch pipes. Each individual underdrain pipe should have a cleanout access location. All piping is to be Schedule 40 PVC. The maximum spacing between rows of perforations should not exceed 6 inches.
- (6) Flow Splitter - The inflow structure to the sedimentation chamber should incorporate a flow-splitting device capable of isolating the capture volume and bypassing the 25-year peak flow around the facility with the sedimentation/filtration pond full.

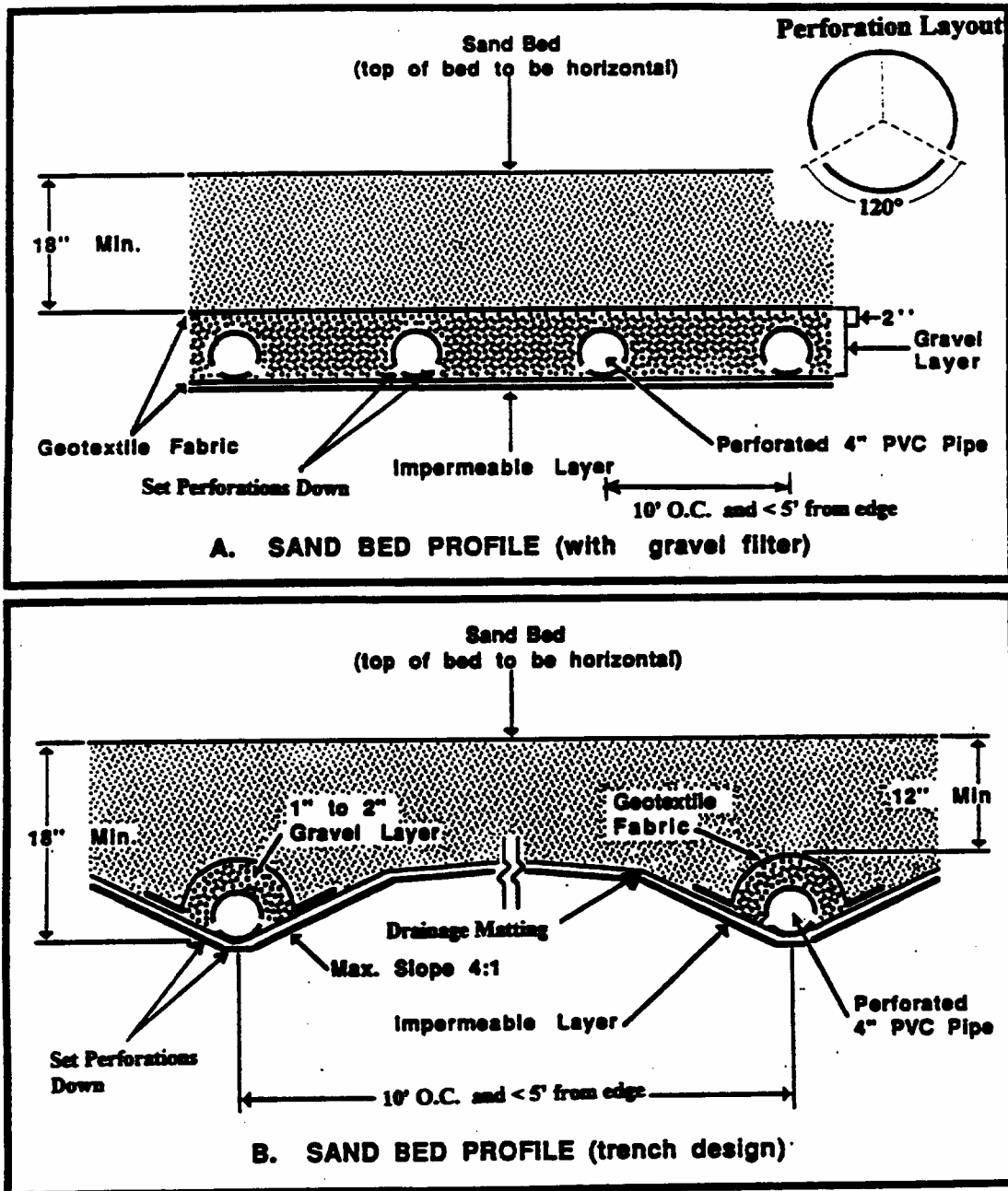

Figure 5
Schematic of Sand Bed Profile

- (7) Basin Inlet – Energy dissipation is required at the sedimentation basin inlet so that flows entering the basin should be distributed uniformly and at low velocity in order to prevent resuspension and encourage quiescent conditions necessary for deposition of solids.
- (8) Sedimentation Pond Outlet Structure - The outflow structure from the sedimentation chamber should be (1) an earthen berm; (2) a concrete wall; or (3) a rock gabion. Gabion outflow structures should extend across the full width of the facility such that no short-circuiting of flows can occur. The gabion rock should be 4 inches in diameter. The

receiving end of the sand filter should be protected (splash pad, riprap, etc.) such that erosion of the sand media does not occur. When a riser pipe is used to connect the sedimentation and filtration basins (example in Figure 6), a valve should be included to isolate the sedimentation basin in case of a hazardous material spill in the watershed. The control for the valve must be accessible at all times, including when the basin is full. The riser pipe should have a minimum diameter of 6 inches with four 1-inch perforations per row. The vertical spacing between rows should be 4 inches (on centers).

- (9) Sand Filter Discharge – If a gabion structure is used to separate the sedimentation and filtration basins, a valve must be installed so that discharge from the BMP can be stopped in case runoff from a spill of hazardous material enters the sand filter. The control for the valve must be accessible at all times, including when the basin is full.

Maintenance

Even though sand filters are generally thought of as one of the higher maintenance BMPs, in a recent California study an average of only about 49 hours a year were required for field activities. This was less maintenance than was required by extended detention basins serving comparable sized catchments. Most maintenance consists of routine removal of trash and debris, especially in Austin sand filters where the outlet riser from the sedimentation basin can become clogged.

Most data (i.e. Clark, 2001) indicate that hydraulic failure from clogging of the sand media occurs before pollutant breakthrough. Typically, only the very top of the sand becomes clogged while the rest remains in relative pristine condition as shown in Figure 7. The rate of clogging has been related to the TSS loading on the filter bed (Urbonas, 1999); however, the data are quite variable. Empirical observation of sites treating urban and highway runoff indicates that clogging of the filter occurs after 2 – 10 years of service. Presumably, this is related to differences in the type and amount of sediment in the catchment areas of the various installations. Once clogging occurs the top 2 – 3 inches of filter media is removed, which restores much, but not all, of the lost permeability. This removal of the surface layer can occur several times before the entire filter bed must be replaced. The cost of the removal of the surface layer is not prohibitive, generally ranging between \$2,000 (EPA Fact Sheet) and \$4,000 (Caltrans, 2002) depending on the size of the filter.

Media filters can become a nuisance due to mosquito and midge breeding in certain designs or if not regularly maintained. "Wet" designs (e.g., MCTT and Delaware filter) are more conducive to vectors than others (e.g., Austin filters) because they maintain permanent sources of standing water where breeding is likely to occur. Caltrans successfully excluded mosquitoes and midges from accessing the permanent water in the sedimentation basin of MCTT installations through use of a tight-fitting aluminum cover to seal vectors out. However, typical wet designs may require routine inspections and treatments by local mosquito and vector control agencies to suppress mosquito production. Vector habitats may also be created in "dry" designs when media filters clog, and/or when features such as level spreaders that hold water over 72 hours are included in the installation. Dry designs such as Austin filters should dewater completely (recommended 72 hour residence time or less) to prevent creating mosquito and other vector habitats. Maintenance efforts to prevent vector breeding in dry designs will need to focus on basic housekeeping practices such as removal of debris accumulations and vegetation management (in filter media) to prevent clogs and/or pools of standing water.

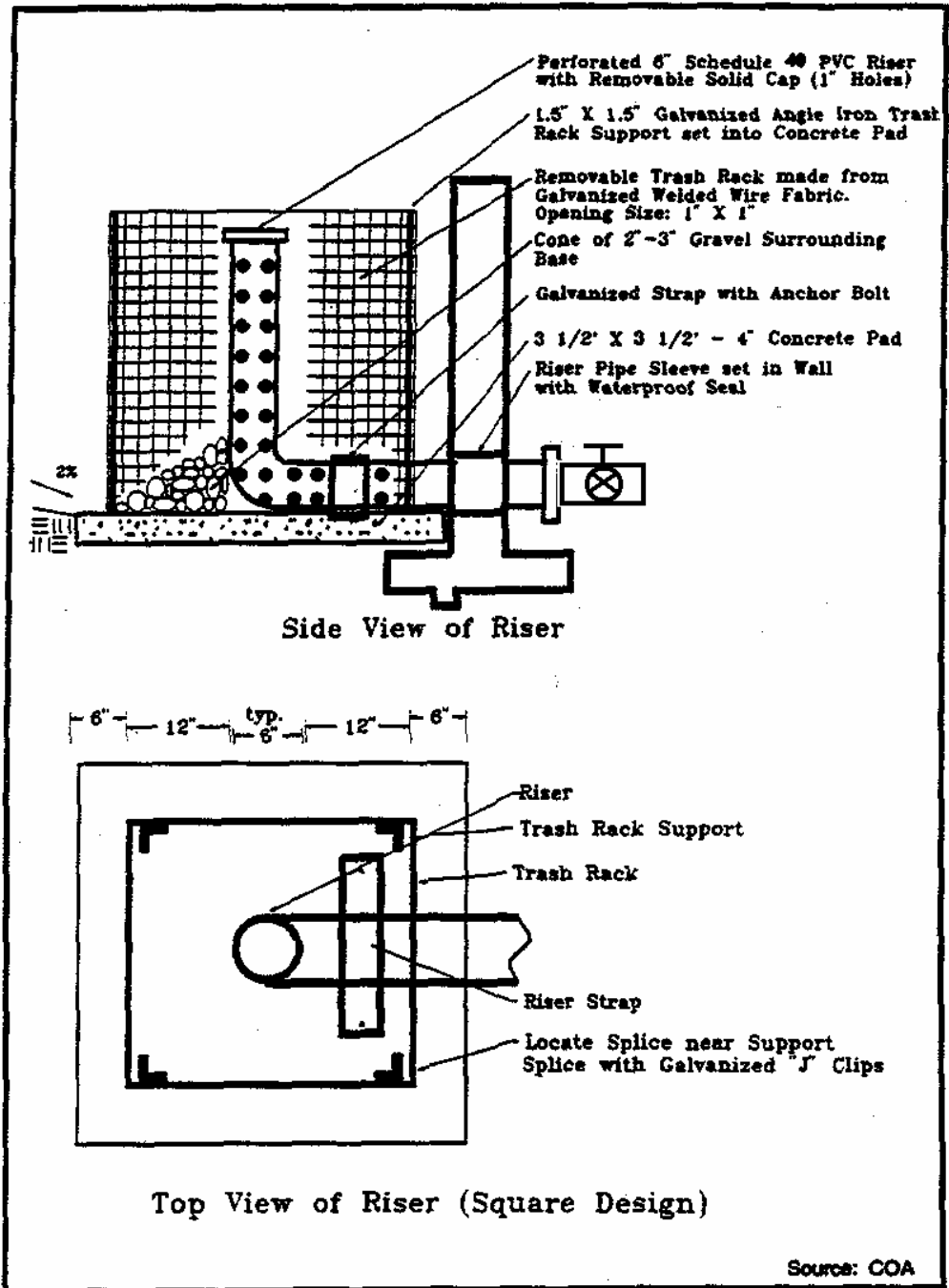

Figure 6
Detail of Sedimentation Riser Pipe



Figure 7
Formation of Clogging Crust on Filter Bed

Recommended maintenance activities and frequencies include:

- Inspections semi-annually for standing water, sediment, trash and debris, and to identify potential problems.
- Remove accumulated trash and debris in the sedimentation basin, from the riser pipe, and the filter bed during routine inspections.
- Inspect the facility once during the wet season after a large rain event to determine whether the facility is draining completely within 72 hr.
- Remove top 50 mm (2 in.) of sand and dispose of sediment if facility drain time exceeds 72 hr. Restore media depth to 450 mm (18 in.) when overall media depth drops to 300 mm (12 in.).
- Remove accumulated sediment in the sedimentation basin every 10 yr or when the sediment occupies 10 percent of the basin volume, whichever is less.

Cost

Construction Cost

There are few consistent published data on the cost of sand filters, largely because, with the exception of Austin, Texas, Alexandria, Virginia, and Washington, D.C., they have not been widely used. Furthermore, filters have such varied designs that it is difficult to assign a cost to filters in general. A study by Brown and Schueler (1997) was unable to find a statistically valid relationship between the volume of water treated in a filter and the cost of the practice. The EPA filter fact sheet indicates a cost for an Austin sand filter at \$18,500 (1997 dollars) for a 0.4 hectare- (1 acre-)

drainage area. However, the same design implemented at a 1.1 ha site by the California Department of Transportation, cost \$240,000. Consequently, there is a tremendous uncertainty about what the average construction cost might be.

It is important to note that, although underground and perimeter sand filters can be more expensive than surface sand filters, they consume no surface space, making them a relatively cost-effective practice in ultra-urban areas where land is at a premium.

Given the number of facilities installed in the areas that promote their use it should be possible to develop fairly accurate construction cost numbers through a more comprehensive survey of municipalities and developers that have implemented these filters.

Maintenance Cost

Annual costs for maintaining sand filter systems average about 5 percent of the initial construction cost (Schueler, 1992). Media is replaced as needed, with the frequency correlated with the solids loading on the filter bed. Currently the sand is being replaced in the D.C. filter systems about every 2 years, while an Austin design might last 3-10 years depending on the watershed characteristics. The cost to replace the gravel layer, filter fabric and top portion of the sand for D.C. sand filters is approximately \$1,700 (1997 dollars).

Caltrans estimated future maintenance costs for the Austin design, assuming a device sized to treat runoff from approximately 4 acres. These estimates are presented in Table 3 and assume a fully burdened hourly rate of \$44 for labor. This estimate is somewhat uncertain, since complete replacement of the filter bed was not required during the period that maintenance costs were recorded.

Activity	Labor Hours	Equipment and Materials (\$)	Cost
Inspections	4	0	176
Maintenance	36	125	1,706
Vector Control	0	0	0
Administration	3	0	132
Direct Costs	-	888	888
Total	43	\$1,013	\$2,902

References and Sources of Additional Information

Barton Springs/Edwards Aquifer Conservation District. 1996. *Final Report: Enhanced Roadway Runoff Best Management Practices*. City of Austin, Drainage Utility, LCRA, TDOT. Austin, TX. 200 pp.

Bell, W., L. Stokes, L.J. Gavan, and T.N. Nguyen. 1995. *Assessment of the Pollutant Removal Efficiencies of Delaware Sand Filter BMPs*. Final Report. Department of Transportation and

Environmental Services. Alexandria, VA. 140 pp. Also in Performance of Delaware Sand Filter Assessed. Watershed Protection Techniques. Center for Watershed Protection. Fall 1995. Vol. 2(1): 291–293.

Brown, W., and T. Schueler. 1997. *The Economics of Stormwater BMPs in the Mid-Atlantic Region*. Prepared for the Chesapeake Research Consortium, Edgewater, MD, by the Center for Watershed Protection, Ellicott City, MD.

Caltrans, 2002, *Proposed Final Report: BMP Retrofit Pilot Program*, California Dept. of Transportation Report CTSW-RT-01-050, Sacramento, CA.

Center for Watershed Protection (CWP). 1996. *Design of Stormwater Filtering Systems*. Prepared for the Chesapeake Research Consortium, Solomons, MD, and U.S. EPA Region 5, Chicago, IL, by the Center for Watershed Protection, Ellicott City, MD.

Center for Watershed Protection (CWP). 1997. Multi-Chamber Treatment Train developed for stormwater hot spots. *Watershed Protection Techniques* 2(3):445–449.

City of Austin, TX. 1990. *Removal Efficiencies of Stormwater Control Structures*. Final Report. Environmental Resource Management Division. 36 p. Also in: Developments in Sand Filter Technology to Improve Stormwater Runoff Quality. Watershed Protection Techniques. Center for Watershed Protection. Summer 1994. Vol. 1(2): 47–54.

City of Austin, TX. 1996. *Design of Water Quality Controls*. City of Austin, TX.

Clark, S.E., 2000, Urban Stormwater Filtration: Optimization of Design Parameters and a Pilot-Scale Evaluation, Ph.D. Dissertation, University of Alabama at Birmingham.

CSF Treatment Systems, Inc. (CSF). 1996. *Stormwater management promotional brochure*. CSF Treatment Systems, Inc., Portland, OR.

Curran, T. 1996. Peat Sand Efficiency Calculations for McGregor Park. Unpublished data. Lower Colorado River Authority. Austin, TX.

Galli, F. 1990. Peat-Sand Filters: *A Proposed Stormwater Management Practice for Urban Areas*. Metropolitan Washington Council of Governments, Washington, DC.

Glick, Roger, Chang, George C., and Barrett, Michael E., 1998, Monitoring and evaluation of stormwater quality control basins, in *Watershed Management: Moving from Theory to Implementation*, Denver, CO, May 3-6, 1998, pp. 369 – 376.

Greb, S., S. Corsi, and R. Waschbush. 1998. Evaluation of Stormceptor© and Multi-Chamber Treatment Train as Urban Retrofit Strategies. Presented at Retrofit Opportunities for Water Resource Protection in Urban Environments, A National Conference. The Westin Hotel, Chicago, IL, February 10–12, 1998.

Harper, H., and J. Herr. 1993. *Treatment Efficiency of Detention With Filtration Systems*. Environmental Research and Design, Inc. Final Report Submitted to Florida Department of Environmental Regulation. Orlando, FL. 164 pp.

Horner, R.R. and Horner, C.R., 1999, Performance of a Perimeter (“Delaware”) Sand Filter in Treating Stormwater Runoff from a Barge Loading Terminal. *Proc. of the Comprehensive Stormwater and Aquatic Ecosystem Management Conf.*, Auckland, N.Z., Feb. 1999, pp. 183-192.

Horner, R.R., and C.R. Horner. 1995. *Design, Construction and Evaluation of a Sand Filter Stormwater Treatment System*. Part II. Performance Monitoring. Report to Alaska Marine Lines, Seattle, WA. 38 p. Also in Performance of Delaware Sand Filter Assessed. *Watershed Protection Techniques*. Center for Watershed Protection. Fall 1995. Vol. 2(1): 291–293.

Keblin, Michael V., Barrett, Michael E., Malina, Joseph F., Jr., Charbeneau, Randall J, 1998, *The Effectiveness of Permanent Highway Runoff Controls: Sedimentation/Filtration Systems*, Research Report 2954-1, Center for Transportation Research, University of Texas at Austin.

King County, Washington, Department of Natural Resources. 2000. *King County Surface Water Design Manual*. <http://splash.metrokc.gov/wlr/dss/manual.htm>. Last updated March 6, 2000. Accessed January 5, 2001.

Leif, T. 1999. *Compost Stormwater Filter Evaluation*. Snohomish County, Washington, Department of Public Works, Everett, WA.

Maryland Department of the Environment (MDE). 2000. *Maryland Stormwater Design Manual*. <http://www.mde.state.md.us/environment/wma/stormwatermanual>. Accessed May 22, 2001.

Metzger, M. E., D. F. Messer, C. L. Beitia, C. M. Myers, and V. L. Kramer. 2002. The fvBMPs. *Stormwater* 3(2): 24-39.

Pitt, R. 1996. The Control of Toxicants at Critical Source Areas. Presented at the ASCE/Engineering Foundation Conference, Snowbird, UT, August 1996.

Pitt, R., M. Lilburn, and S. Burian. 1997. *Storm Drainage Design for the Future: Summary of Current U.S. EPA Research*. American Society of Civil Engineers Technical Conference, Gulf Shores, AL, July 1997.

Robertson, B., R. Pitt, A. Ayyoubi, and R. Field. 1995. A Multi-Chambered Stormwater Treatment Train. In *Proceedings of the Engineering Foundation Conference: Stormwater NPDES-Related Monitoring Needs, Mt. Crested Butte, Colorado, August 7–12, 1994*, American Society of Civil Engineers, New York, New York.

Schueler, T. 1994. Developments in sand filter technology to improve stormwater runoff quality. *Watershed Protection Techniques* 1(2):47–54.

Schueler, T. 1997. Comparative Pollutant Removal Capability of Urban BMPs: A Reanalysis. *Watershed Protection Techniques* 2(4):515–520.

Stewart, W. 1992. *Compost Stormwater Treatment System*. W&H Pacific Consultants. Draft Report. Portland, OR. Also in Innovative Leaf Compost System Used to Filter Runoff at Small Sites in the Northwest. *Watershed Protection Techniques*. Center for Watershed Protection. February 1994. Vol. 1(1): 13–14.

Urbonas, B.R, 1999, Design of a sand filter for stormwater quality enhancement, Water Environment Research, V. 71, No. 1, pp. 102-113.

U.S. EPA, 1999, Stormwater Technology Fact Sheet: Sand Filters, Report EPA 832-F-99-007 <http://www.epa.gov/owm/mtb/sandfltr.pdf>, Office of Water, Washington, DC

Washington State Department of Ecology (DOE). 1992. *Stormwater Management Manual for the Puget Sound Basin*, Washington State Department of Ecology, Olympia, WA.

Watershed Management Institute (WMI). 1997. *Operation, Maintenance, and Management of Stormwater Management Systems*. Prepared for U.S. EPA Office of Water, Washington, DC, by Watershed Management Institute.

Welborn, C., and J. Veenhuis. 1987. *Effects of Runoff Controls on the Quantity and Quality of Urban Runoff in Two Locations in Austin, TX*. USGS Water Resources Investigations Report. 87-4004. 88 pp.

Young, G.K., et al., 1996, *Evaluation and Management of Highway Runoff Water Quality*, Publication No. FHWA-PD-96-032, U.S. Department of Transportation, Federal Highway Administration, Office of Environment and Planning.

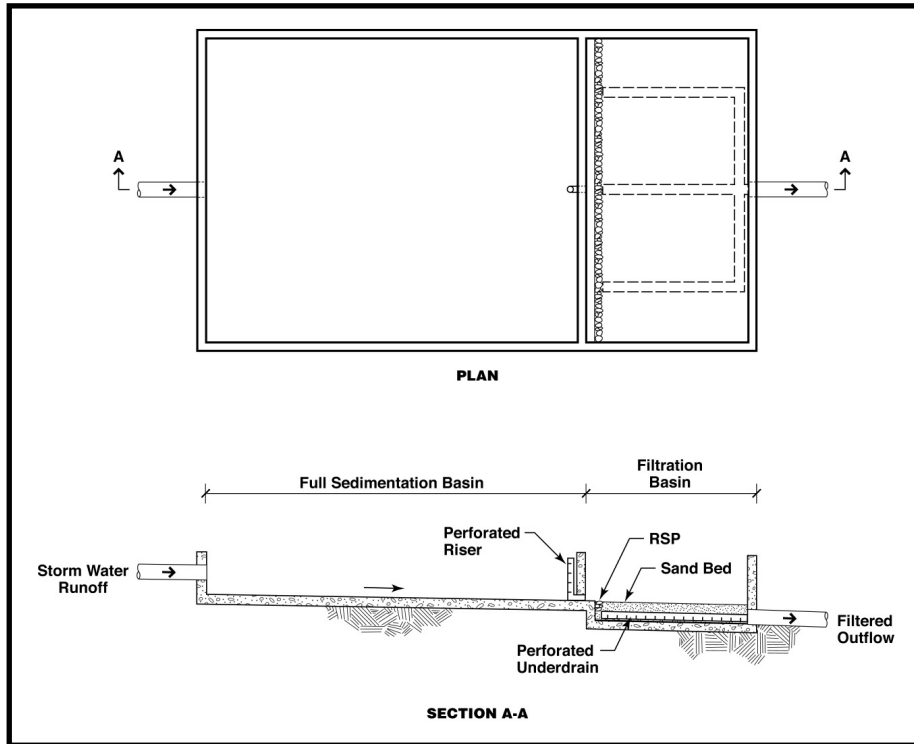

Schematic of the "Full Sedimentation" Austin Sand Filter

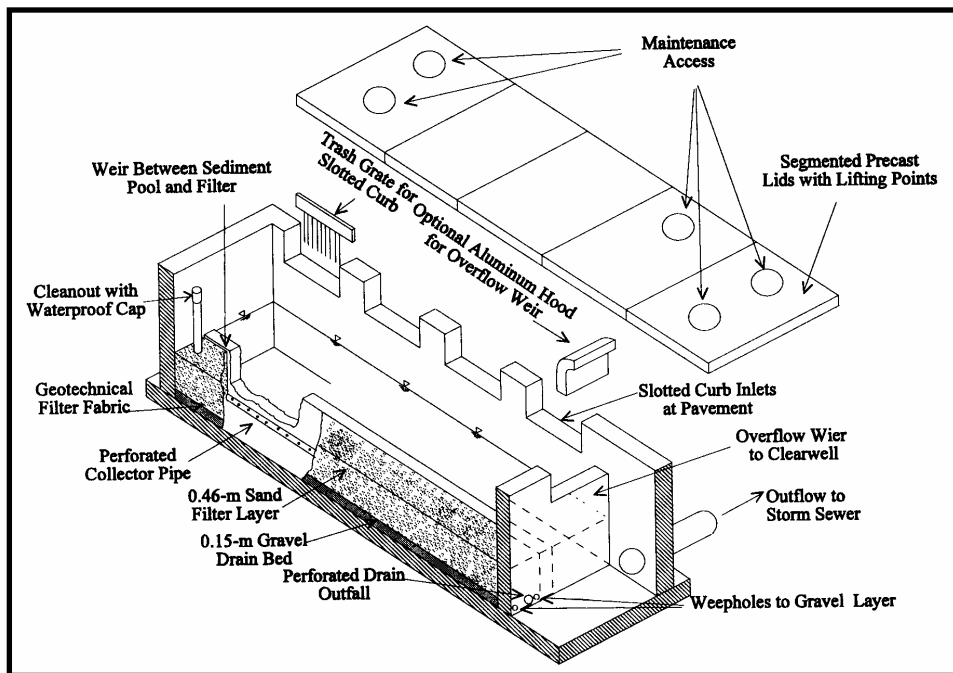

Schematic of a Delaware Sand Filter (Young et al., 1996)

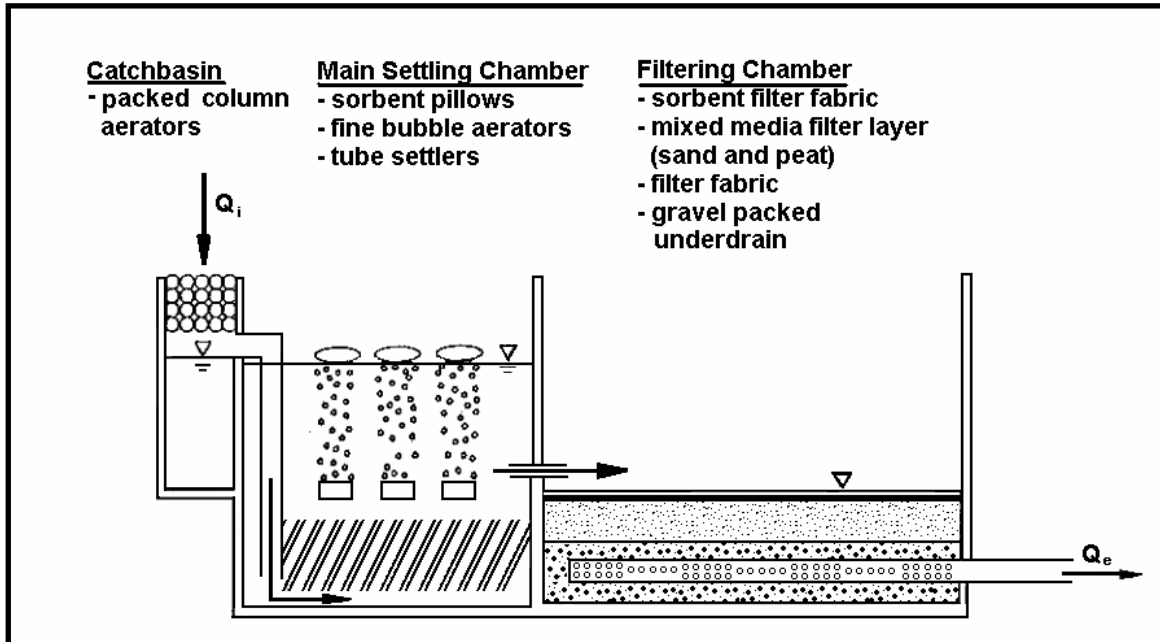

Schematic of a MCTT (Robertson et al., 1995)