



January 6, 2023

Mr. Leo Cosentini  
California State Water Resources Control Board  
Division of Water Quality  
P.O. Box 100  
Sacramento, CA 95812-100

**Re: Updated Application for Trash Treatment Control Device,  
Aqua-Swirl® Stormwater Treatment System**

Dear Mr. Cosentini,

AquaShield™, Inc. is pleased to submit this Updated Application for the Aqua-Swirl® Stormwater Treatment System (Aqua-Swirl®) for continued use as a Trash Treatment Control Device. This application is submitted in accordance with the CSWRCB document *Application Requirements for Trash Full Capture System Certification (Updated September 2022)*. Specifically, this update includes information included in the currently posted application available at:

[https://www.waterboards.ca.gov/water\\_issues/programs/stormwater/docs/trash\\_implementation/2022/application-requirements-09092022.pdf](https://www.waterboards.ca.gov/water_issues/programs/stormwater/docs/trash_implementation/2022/application-requirements-09092022.pdf).

Aqua-Swirl® trash treatment control models AS-5s through AS-12s are now available in one-half foot larger diameters than those previously used. This results in higher treatment flow rates, trash capture capacity and water storage volumes for those models. There are no changes to the AS-2s, AS-3s, AS-4s and AS-13s. Information sought via the September 2022 updated application is also addressed herein.

Thank you for considering this updated application and please do not hesitate to contact us if additional information is needed.

Respectfully submitted,

**AquaShield™, Inc.**

Mark B. Miller, P.G.  
Research Scientist

cc: John Santos, AquaShield™ Western Business Development Manager



## 1.0 COVER LETTER

### 1.A. *General description of the device.*

The Aqua-Swirl<sup>®</sup> is a custom engineered, post-construction flow-through stormwater treatment device designed to remove trash, suspended sediment, floating debris and free-floating oil by utilizing hydrodynamic vortex-enhanced separation. Water must pass through a screen affixed to the base of the inner arched baffle which traps trash particles of 5.0 mm or more before exiting the device behind the baffle.

### 1.B. *The applicant's contact information and location.*

The AquaShield<sup>™</sup> authorized representative is:

Eric B. Rominger  
Vice President  
2733 Kanasita Drive, Suite 111  
Chattanooga, TN 37343  
(423) 870-8888  
[erominger@aquashieldinc.com](mailto:erominger@aquashieldinc.com)

The AquaShield<sup>™</sup> contact located in California is:

John Santos  
Western Business Development Manager  
AquaShield<sup>™</sup>, Inc.  
9580 Oak Avenue, Suite 7-203  
Folsom, CA 95630  
916-850-9879  
[jsantos@aquashieldinc.com](mailto:jsantos@aquashieldinc.com)

The AquaShield<sup>™</sup> technical contact at corporate headquarters is:

Mark B. Miller, P.G.  
Research Scientist  
AquaShield<sup>™</sup>, Inc.  
2733 Kanasita Drive, Suite 111  
Chattanooga, TN 37343  
888-344-9044  
[mmiller@aquashieldinc.com](mailto:mmiller@aquashieldinc.com)

**1.C.** *Applicant's webpage address where the system can be found on the applicant's website:*

Website: <https://www.aquashieldinc.com/>

Aqua-Swirl® webpage: <https://www.aquashieldinc.com/--aqua-swirl.html>

**1.D.** *The device's manufacturing location.*

AquaShield™ currently utilizes eight independent fabrication facilities strategically located across the United States to provide timely and cost-effective service and delivery to our customers. California projects will most likely rely on any of three facilities located in Billings, MT, Eunice, NM and Elkhart, TX. Other facilities may be used as needed.

**1.E.** *A brief summary of any field/lab testing results that demonstrate the Device functions as described within the Application.*

A laboratory test of a full scale, commercially available Aqua-Swirl® Model AS-3s has been performed in the presence of an independent observer to document 100% trash retention. The test unit has a 3.5-foot diameter swirl chamber and a 4.6 ft<sup>2</sup> trash retention screen with 4.76 mm absolute diameter perforations to prevent trash particles of 5.0 mm and greater in size from escaping the device. Three trash retention runs used a simulated trash composition that was progressively added to existing material for each run. Surface area loading rates ranged from 21 to 98 gpm/ft<sup>2</sup>. No trash was observed in the effluent stream, in netting at the end of the discharge pipe, or in the reserve water tank. Refer to **Appendix G** for the supporting report titled *Laboratory Testing of the Aqua-Swirl® Stormwater Treatment System Model AS-3s for Trash Retention*, March 28, 2017.

**1.F.** *A brief summary of the Device limitations, and operational, sizing, and maintenance considerations.*

The Aqua-Swirl® is an engineered stormwater quality system designed to meet site-specific flow conditions. Unstable native soils or excessively steep hill slopes may require engineered solutions to allow for proper installation and operation. The slope of the drainage pipe is important to ensure proper water conveyance through a facility. No driving head is needed for operation other than that associated with the slope of the drainage pipes.

Aqua-Swirl® systems are sized according to the water quality treatment flow rate (WQTFR) for a site design. Undersized facilities can create undesirable flow conditions (flooding) while oversized units may unnecessarily increase a facility's footprint and project costs. AquaShield™ agents and staff collaborate with specifying engineers to better ensure proper sizing.

The online Aqua-Swirl® "BYP" models are designed to convey both the WQTFR and the peak flow. An internal weir of the Aqua-Swirl® BYP models directs the WQTFR flow to the swirl chamber while bypass flows occur above the weir such that the two flow paths never mix within the treatment area of the swirl chamber. Pipe sizing should be considered for installations to meet a facility's flow volume conveyance requirement.

AquaShield™ recommends that any stormwater treatment installation should be designed with maintenance in mind. For example, if a facility is located such that maintenance equipment (e.g.,

vacuum truck) cannot access the device for any reason, then performance and long term functionality will eventually not be met.

Aqua-Swirl® systems should be inspected and maintained following the recommendations and guidelines included in the Aqua-Swirl® Inspection & Maintenance Manual that is provided for all site installations. AquaShield™ recommends quarterly inspections for the first year of operation to establish an anticipated maintenance frequency. AquaShield™ also recommends annual maintenance events. The single treatment/storage chamber facilitates inspection and maintenance since there is full access to the swirl chamber with no hidden or blind access chambers within the device. All maintenance-related activities are performed from the surface and no confined space entry is needed.

**1.G.** *A description or list of locations, if any, where the Device has been installed. Include the name and contact information of as many as three municipality(s) purchasing the Device.*

Select example projects, locations and models are tabulated below for the Aqua-Swirl® full trash capture device installations in California. Two municipal contacts are listed below.

<b><u>Example Projects for Aqua-Swirl® Full Trash Capture Device</u></b>		
<b>Project</b>	<b>City</b>	<b>Units</b>
Stormwater Trash Collection - Phase 1	Lodi	AS-8s BYP
Manteca High School	Manteca	AS-3s BYP
Torrance Circle	Redondo Beach	AS-12s Offline AS-2s Offline
Villages at Civic Center	Rocklin	AS-3s BYP AS-6s Offline
Walmart Supercenter	Tehachapi	AS-4s (3) BYP
<b>Municipal Contacts</b>		
City of Redondo Beach - Saila Potukuchi, Associate Civil Engineer; <a href="mailto:Saila.Potukuchi@Redondo.org">Saila.Potukuchi@Redondo.org</a>		
City of Lodi - Alice Bernardino, Assistant Engineer; <a href="mailto:abernardino@lodi.gov">abernardino@lodi.gov</a>		

**1.H.** *If the system is designed to operate outside of a typical stormwater catch basin and is able to trap trash from high flows, indicate a preference to be listed as a high flow capacity System on the State Water Board’s website.*

The Aqua-Swirl® trash capture system is designed to operate outside of a typical catch basin. Preference is to be listed as a high flow capacity system.

**1.I. Certification Statement.**

*I certify under penalty of law that this document and all attachments were prepared under my direction or supervision in accordance with a system designed to assure that qualified personnel properly gather and evaluate the information submitted. Based on my inquiry of the person or persons that manage the system or those persons directly responsible for gathering the information, to the best of my knowledge and belief, the information submitted is, true, accurate, and complete. I am aware that there are significant penalties for submitting false information, including the possibility of fine and imprisonment for knowing violations.*

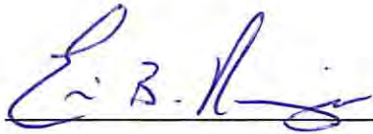

**Eric B. Rominger, Vice President**

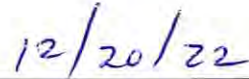

**Date**

## 2.0 TABLE of CONTENTS

	<u>Page Number</u>
<b>1.0 Cover Letter</b>	<b>2</b>
Subsection 1.A	2
Subsection 1.B	2
Subsection 1.C	3
Subsection 1.D	3
Subsection 1.E	3
Subsection 1.F	3
Subsection 1.G	4
Subsection 1.H	4
Subsection 1I (Signature Page)	5
<b>3.0 Physical Description</b>	<b>8</b>
Subsection 3.A	8
Subsection 3.B	8
Subsection 3.C	9
Subsection 3.D	10
Subsection 3.E	10
Subsection 3.F	11
Subsection 3.G	11
Subsection 3.H	11
Subsection 3.I	11
Subsection 3.I [sic]	11
Subsection 3.J	11
Subsection 3.K	12
<b>4.0 Installation Information</b>	<b>12</b>
Subsection 4.A	12
Subsection 4.B	12
Subsection 4.C	12
<b>5.0 Operation and Maintenance Information</b>	<b>13</b>
Subsection 5.A	13
Subsection 5.B	14
Subsection 5.C	14
Subsection 5.D	14
Subsection 5.E	14
Subsection 5.F	14
<b>6.0 Vector Control Accessibility</b>	<b>15</b>
Subsection 6.A	15
Subsection 6.B	15
Subsection 6.C (MVCAC Letter of Verification)	15

<b>7.0</b>	<b>Reliability</b>	<b>16</b>
	Subsection 7.A	16
	Subsection 7.B	16
	Subsection 7.C	16
<b>8.0</b>	<b>Field/Lab Testing Information and Analysis</b>	<b>16</b>
	Subsection 8.A	16
	Subsection 8.B	16

### **List of Figures**

Figure 1. View Through Riser of Treatment/Storage Area	15
--	----

### **List of Tables**

Table 1. Aqua-Swirl <sup>®</sup> Sizing Chart	9
Table 2. Aqua-Swirl <sup>®</sup> Hydraulic Capacity at 50% Blinding and 100% Trash Capture Volume	9
Table 3. Aqua-Swirl <sup>®</sup> Water Storage Volumes	10

### **Appendices**

Appendix A.	Aqua-Swirl <sup>®</sup> BYP Design Drawings
Appendix B.	Photographs of Aqua-Swirl <sup>®</sup> BYP Installations
Appendix C.	Aqua-Swirl <sup>®</sup> Specifications for PCS Material, Installation and Backfill
Appendix D.	Aqua-Swirl <sup>®</sup> Inspection & Maintenance Manual
Appendix E.	MVCAC Letter of Verification
Appendix F.	AquaShield <sup>™</sup> Limited Warranty
Appendix G.	<i>Laboratory Testing of the Aqua-Swirl<sup>®</sup> Stormwater Treatment System Model AS-3s for Trash Retention</i>

### 3.0 PHYSICAL DESCRIPTION

**3.A. Trash Capture:** *Describe how the System traps trash particles 5-millimeters or greater. Unless the System is designed to self-clean the screen or filter area, screen and filters sizes must be between 4.5 to 5 millimeters. Expandable filters must be sized between 4.5 to 5 millimeters at peak hydraulic capacity at 50 percent screen binding.*

The Aqua-Swirl<sup>®</sup> Stormwater Treatment System (Aqua-Swirl<sup>®</sup>) is a custom engineered, post-construction flow-through structure designed to remove trash, suspended sediment, floating debris and free-floating oil. Aqua-Swirl<sup>®</sup> technology is a rapid or high flow rate device that relies on hydrodynamic vortex-enhanced separation. The Aqua-Swirl<sup>®</sup> has no moving parts and operates on gravity flow or movement of the stormwater runoff entering the structure. For use in California, the Aqua-Swirl<sup>®</sup> includes a built-in screen to capture trash particles of 5.0 mm or more. Refer to Figure 1 in the report attached in **Appendix G** for an illustration of the Aqua-Swirl<sup>®</sup> design, screen and water flow path through the device.

Operation begins when stormwater enters the single chamber Aqua-Swirl<sup>®</sup> by means of its tangential inlet pipe thereby inducing a circular (swirl or vortex) flow pattern. The diameter of the swirl chamber represents the effective treatment area of the device. Both material capture and storage are accomplished within the swirl chamber. A combination of dynamic gravitational and hydrodynamic drag forces results in solids dropping out of the flow and migrating to the center of the swirl chamber where velocities are the lowest. Flow circulates downward where water flows through the trash screen at the base of the arched inner baffle then exits upward behind the baffle. Quiescent settling occurs between flow events. The top of the baffle is sealed across the treatment channel to eliminate floatable pollutants from escaping the swirl chamber. A vent pipe is extended up the riser to expose the backside of the baffle to atmospheric conditions, thus preventing a siphon from forming at the bottom of the baffle. The base of the screen is sealed to prevent materials from escaping beneath the screen.

All water must pass through the trash screen to exit the device. Trash is captured using a screen attached to the base of the inner arched baffle to prevent material 5.0 mm and greater in size from escaping the device. Screen perforations have an absolute diameter of 4.76 mm. The vortex flow sweeps material from the trash capture screen. Sediment and settleable solids are stored at the base of the swirl chamber while floatables remain captured within the treatment area on the upstream side of the arched baffle.

**3.B. Peak Flows/Trash Capture Volumes:** *Explain how the System is sized for varying peak flow rates and trash capture volumes.*

An Aqua-Swirl<sup>®</sup> sizing chart is shown below in **Table 1**. Full trash capture models are identified by their diameters with sequential model designations of AS-2s through AS-13s. Note that models AS-2s sequentially through AS-12s have diameters of 2.5 sequentially through 12.5 feet, respectively, while model AS-13s uses the actual device diameter. Corresponding water quality treatment flow rates (WQTFR) are listed for each model. Trash capture volumes are also listed in the table. Multiple, or twin units can be custom designed for site-specific WQTFRs that exceed the AS-13s treatment capacity.



**Table 1. Aqua-Swirl® Sizing Chart for California Trash Capture**

Aqua-Swirl® Model	Diameter (ft)	Water Quality Treatment Flow Rate (cfs)	Trash Capture Volume (ft <sup>3</sup> )
AS-2s	2.5	1.1	1.0
AS-3s	3.5	2.1	2.1
AS-4s	4.5	3.5	3.5
AS-5s	5.5	5.3	5.3
AS-6s	6.5	7.4	7.5
AS-7s	7.5	9.8	10.0
AS-8s	8.5	12.6	12.9
AS-9s	9.5	15.8	16.2
AS-10s	10.5	19.3	19.9
AS-11s	11.5	23.1	23.9
AS-12s	12.5	27.3	28.3
AS-13s	13.0	29.6	30.6
AS-Xs*	Custom*	>29.6	Custom*

\* Custom designs to meet site-specific WQTFR and can include multiple (twin) units.

**3.C. Hydraulic Capacity**

- 1) *For all standard sizes, provide a table of the hydraulic capacity for the conditions of no screen blinding and zero trash capture in the System and at several intervals of screen blinding (including 50 percent), or trash capture volume.*

**Table 2** lists the Aqua-Swirl® hydraulic capacity at 50% screen blinding and 100% trash capture volume.

**Table 2. Aqua-Swirl® Hydraulic Capacity at 50% Blinding and 100% Trash Capture Volume**

Model	Diameter (ft)	Treatment Capacity (cfs)
AS-2s	2.5	1.1
AS-3s	3.5	2.1
AS-4s	4.5	3.5
AS-5s	5.5	5.3
AS-6s	6.5	7.4
AS-7s	7.5	9.8
AS-8s	8.5	12.6
AS-9s	9.5	15.8
AS-10s	10.5	19.3
AS-11s	11.5	23.1
AS-12s	12.5	27.3
AS-13s	13	29.6

- 2) *Provide the methods or equations used to determine hydraulic capacity. If equations are used, provide one example.*

All Aqua-Swirl® trash capture tests were performed utilizing 48% of a commercially available system’s trash screen area. These tests were also performed at up to 100% trash capture volume. Because no loss of hydraulic capacity was observed during these test runs, commercially available Aqua-Swirl® trash capture systems will not experience any loss of hydraulic capacity at up to 50% screen blinding or 100% trash capture volume.

- 3) *If the System has alternative configurations that impact the hydraulic capacity, include a table of the hydraulic capacity for each System configuration.*

Not applicable.

**3.D. Comparison Table:** *For all standard sizes, provide a table that includes the peak flow rates and recommended maximum trash capture volume.*

**Table 3** below compares the water quality treatment flow rate to the water storage volumes for each of the Aqua-Swirl® models.

**Table 3. Aqua-Swirl® Treatment Flow Rates and Water Storage Volumes**

<b>Aqua-Swirl® Model</b>	<b>Water Quality Treatment Flow Rate (cfs)</b>	<b>Water Storage Volume (gal)</b>
AS-2s	1.1	116
AS-3s	2.1	407
AS-4s	3.5	674
AS-5s	5.3	1,008
AS-6s	7.4	1,407
AS-7s	9.8	1,874
AS-8s	12.6	2,403
AS-9s	15.8	3,005
AS-10s	19.3	3,671
AS-11s	23.1	4,404
AS-12s	27.3	5,201
AS-13s	29.6	5,625

**3.E. Design Drawings:** *Provide design drawings for all standard System sizes and, if any, alternative configurations (e.g., deflector screen, filter media, etc.). Design drawings should depict the System from the top, side, and three-dimensional perspective. If the system includes features for vector control accessibility, drawings should include the vector control accessibility features.*

Design drawings are included in **Appendix A** for the online Aqua-Swirl<sup>®</sup> BYP designs for Models AS-2s through AS-13s. The drawings include top views (plan), side views (elevation) and an external three-dimensional view (projected).

**3.F. Alternative Configurations:** *If the System includes two or more configurations, explain the purpose of each configuration and any mandatory installation conditions.*

Not applicable.

**3.G. Internal Bypass:** *If the system has an internal bypass, explain how the bypass functions to only allow a bypass of flows exceeding the peak flow rate.*

Aqua-Swirl<sup>®</sup> “BYP” systems are available for online configurations. These models are designed with an internal bypass weir positioned within the inlet pipe to allow for flows up to the treatment flow rate to enter the treatment chamber while any flow in excess of the treatment flow rate is bypassed without treatment. The cross-sectional area of the inlet below the weir is computed using the orifice equation:

$$A = Q / KV$$

Where:

$$Q = WQTFR$$

$$K = \text{dimensionless constant (0.62)}$$

$$V = (2gh)^{0.5}$$

Once the orifice area is computed, the elevation of the bypass weir can be derived based on the pipe diameter.

**3.H. Previously Trapped Trash:** *Explain the condition(s) under which the System re-introduces previously trapped trash (e.g., via the internal bypass).*

The trash retention screen in the Aqua-Swirl<sup>®</sup> uses 4.76 mm absolute diameter perforations to eliminate larger particles from escaping the swirl chamber. Although unlikely, a broken screen could potentially re-introduce previously trapped trash to the effluent.

**3.I. Calibration Feature:** *If the System includes an adjustable calibration feature, describe how the calibration feature functions.*

Not applicable.

**3.I [sic] Photos:** *If any, provide the System installation photographs.*

Four installation photographs of Aqua-Swirl<sup>®</sup> BYP systems are included in **Appendix B**.

**3.J. Material Type:** *Provide each material and material grade used to construct the System (e.g., stainless steel, plastic, etc.).*

Aqua-Swirl<sup>®</sup> systems are constructed of polymer coated steel (PCS). The modular design allows for units to be delivered without the need for on-site assembly. **Appendix C** includes Aqua-Swirl<sup>®</sup> Specifications for PCS that include descriptions of Materials, Performance, Treatment

Chamber Construction, Installation, Division of Responsibility, Submittals and Quality Control Inspection.

**3.K. *Design Life:*** *Provide the estimated design life.*

The estimated design life for systems is 75+ years. According to the National Corrugated Steel Pipe Association, PCS can achieve a 100-year service life (NCSPA, *Pipe Selection Guide*, page 6, Figure 3).

## **4.0 INSTALLATION GUIDANCE**

**4.A. *Standard System installation procedures including calibration instructions if applicable.***

Installation and backfill procedures are described in the Aqua-Swirl<sup>®</sup> Specifications document attached in **Appendix C**. Calibration instructions are not applicable.

Installation is generally a straightforward process. A backhoe or trackhoe can be used in lieu of a crane given the system's lightweight and modular design. There is no need for onsite assembly. Mar-Mac, Fernco, Mission or equal type flexible boots with stainless steel tension bands are used for pipe couplings. Such pipe couplings are commonly used by contractors which minimizes the potential for faulty pipe connections.

AquaShield<sup>™</sup> performs buoyancy calculations for installations that have a shallow groundwater table. If required, concrete should be poured across the base plate for anti-floatation security.

PCS systems are constructed for HS-25 loading.

Our engineers can assist stakeholders with unique site-specific installation considerations.

As a precaution for leakage, all units are hydraulically tested at the fabrication facility to ensure that there are no leaks prior to shipment. Units are filled with water and observed such that any needed repairs can be made at that time.

**4.B. *Description of System installation limitations and/or non-standard System installation procedures.***

Pick weights vary by Aqua-Swirl<sup>®</sup> model size. AquaShield<sup>™</sup> can provide contractors with model specific pick weights prior to delivery.

AquaShield<sup>™</sup> routinely performs buoyancy calculations where a shallow groundwater condition may be present. It is recommended that concrete be poured to better ensure device security within the excavation.

AquaShield<sup>™</sup> specifies that stone backfill material be used. Site-specific native soils can be used as backfill provided that the material substantially conforms to the backfill specification.

**4.C. *Methods for diagnosing and correcting installation errors.***

The modular design of the system minimizes installation errors since there are no moving parts and no need for on-site assembly. The installation process is a relatively simple process.

As a precaution for leakage, all units are hydraulically tested at the fabrication facility to ensure that there are no leaks prior to shipment. Units are filled with water and observed such that any needed repairs can be made at that time.

To prevent systems from being installed backwards, both the inlet and outlet pipe stubouts on all units are clearly labeled prior to shipment from the fabrication facility. Riser pipes are capped for shipping.

It is envisioned that any installation error for any trash capture device would manifest itself via adverse flow conditions and/or diminished functionality for a variety of reasons. Examples could include, but not be limited to (a) facility undersizing, (b) inaccurate design and/or installation of conveyance piping and associated slope elevations, (c) obstruction(s) in influent and/or effluent conveyance piping, or (d) lack of maintenance. Should ruling these factors out fail to diagnose an installation error, then a site-specific condition would need to be assessed to solve the problem(s).

## **5.0 OPERATION AND MAINTENANCE INFORMATION**

### **5.A. *Inspection procedures and frequency considerations.***

An Aqua-Swirl<sup>®</sup> Inspection and Maintenance Manual is included as **Appendix D**. This manual is provided for every site delivery for stakeholders to understand system operations and track and document system inspection and maintenance cycles. AquaShield<sup>™</sup> recommends that periodic system inspections be performed to determine whether the disposal of captured material is needed to ensure proper operation of the treatment system.

Upon installation and during construction, AquaShield<sup>™</sup> recommends that an Aqua-Swirl<sup>®</sup> treatment system be inspected every three months and the system be cleaned as needed. A typical maintenance event for the cleaning of the swirl chamber can be accomplished with a vacuum truck without the need to enter the chamber. A unit should be inspected and cleaned at the end of construction regardless of whether it has reached its material (including trash) storage capacity. During the first year of post-construction, the unit should again be inspected every three months and cleaned as needed. We recommend that the system be inspected and cleaned once annually regardless of whether it has reached its pollutant storage capacity. For the second and subsequent years post-construction, the system can be inspected and cleaned once annually if the system did not reach full pollutant capacity in the first-year post-construction. If the device reached full pollutant capacity in less than 12 months in the first-year post-construction, it should be inspected once every six months and cleaned as needed. We further recommend that all external bypass structures (divergent and convergent) should be inspected whenever an inspection and maintenance event is performed. These structures can adversely affect performance and functionality if left unchecked.

Essential elements of a swirl chamber inspection include observing floating materials, trash and measuring the accumulated sediment at the base of the swirl chamber. These activities can be performed at the ground surface for a typical subsurface installation and there is no need to enter the device. Provided that there are no significant access restrictions to the facility, it is considered that a system inspection should not exceed one half hour. A typical maintenance event includes vacuuming and disposal of captured material from the swirl concentrator.

Cleaning of the swirl chamber is often accomplished by using a vacuum truck. It is estimated that on-site activities for maintenance should not exceed one hour. No special training is needed for technicians to inspect or maintain a unit. We recommend that if entry to the swirl chamber is necessary for any reason, then confined space entry techniques should be followed after water is removed from the structure.

Proper health and safety protocols should be followed during all inspection and maintenance events. We recommend that all materials removed during the maintenance process be handled and disposed of in accordance with all applicable federal, state and local guidelines. Depending on the influent pollutant characteristics of the system drainage area, it may be appropriate to perform Toxicity Characteristics Leaching Procedure (TCLP) analyses on representative samples of the removed material to ensure that the handling and disposition of materials comply with all applicable regulations.

**5.B.** *Description of maintenance frequency considerations related to the System's hydraulic capacity at various levels of trash capture volumes (see section 3, above).*

The Aqua-Swirl® trash capture system should be maintained according to the Inspection & Maintenance Manual to maintain design hydraulic capacity.

**5.C.** *Maintenance procedures, including procedures to clean the trash capture screen.*

Aqua-Swirl® trash capture devices can typically be cleaned using a vacuum truck. Access to the single treatment/storage swirl chamber is from the surface. There are no blind chambers to access. The trash screen can also be cleaned using the same vacuum truck by simply applying the vacuum apparatus directly upon the screen using a sweeping or vacuuming motion on its surface facing the swirl chamber. Sediment that has accumulated at the base of the swirl chamber can also be removed at this time.

**5.D.** *Essential equipment and materials for proper maintenance activities.*

In addition to the vacuum truck, a flashlight may be useful for viewing internal conditions. A manhole lift hook is often used to assist with opening access to the swirl chamber. Otherwise, no other special equipment is needed to complete a maintenance event.

**5.E.** *Description of the effects of deferred maintenance on System structural integrity, performance, odors, etc.*

While deferred maintenance will not adversely impact the structural integrity of the Aqua-Swirl® trash capture device, lack of maintenance could yield diminished performance in terms of flow conveyance or effluent water quality if the trash and/or sediment retention capacity is exceeded.

**5.F.** *Repairs procedure for the System's structural and screening components.*

It is unlikely that repairs will be needed for structural and screening components. These components are fabricated from steel and should not be subjected to conditions that would cause damage to a unit. If the screen component were to become damaged it would be necessary to access the unit to assess the extent of damage to determine an appropriate course of action to make a repair.

## 6.0 Vector Control Accessibility

**6.A.** *The date the System application was submitted for vector control accessibility design verification via email the Mosquito Vector Control Association of California at [trashtreatment@mvacac.org](mailto:trashtreatment@mvacac.org).*

Not applicable since the verification letter has been issued.

**6.B.** *The description and/or video that demonstrates how mosquito vector control personnel can readily access the bottom of the storm water vault and/or System for visual observation and mosquito treatment.*

Captured trash and standing water is easily accessible from the surface without the need for confined space entry techniques. A blind pick manhole covers the entire riser pipe, or multiple riser pipes for larger units. Removal of this manhole cover(s) allows for direct and open access to the single treatment and material storage chamber of the Aqua-Swirl<sup>®</sup>. There are no obstructions to the treatment/storage area of the device and there are no inaccessible or hidden chambers within the device. This open access allows for complete inspections and cleaning from the surface. A photograph is provided below in **Figure 1** showing the treatment/storage area and screen area as viewed down through the riser pipe. The bottom of the unit can be accessed via confined space entry after all water and materials have been removed from the treatment/storage swirl chamber.

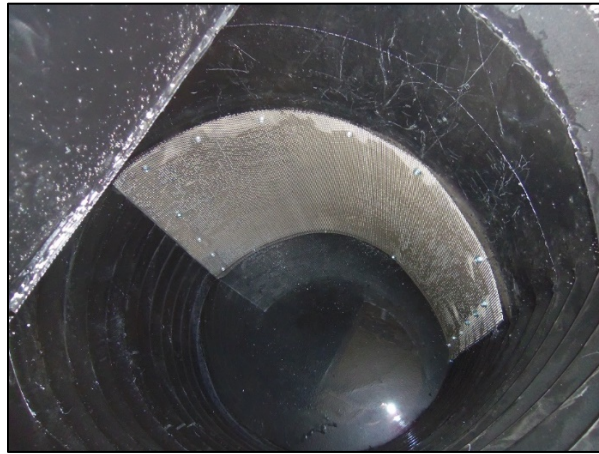

**Figure 1.** View down through riser pipe and into treatment/storage area of the Aqua-Swirl<sup>®</sup>. The stainless steel trash capture screen is white in color and is positioned below that arched inner baffle. The base plate of the unit coincides with the flashlight reflection.

### 6.C. MVCAC Letter of Verification

The Mosquito Vector Control Association of California (MVCAC) Letter of Verification dated January 6, 2023 is included in **Appendix E**.

## 7.0 Reliability Information

### 7.A. *Estimated design life of System components before major overhaul.*

The estimated design life for systems is 75+ years. According to the National Corrugated Steel Pipe Association, PCS can achieve a 100-year service life (NCSPA, *Pipe Selection Guide*, page 6, Figure 3).

### 7.B. *Warranty Information.*

AquaShield™ provides a one-year limited warranty for each device (**Appendix F**).

### 7.C. *Customer support information.*

AquaShield™ strives to provide customer support in a timely and efficient manner to serve the diverse needs of design engineers, contractors, those in the regulatory community and others involved with a project. Local agents actively collaborate with stakeholders to provide site-specific assistance for the design, quotation, delivery, installation, and maintenance of our systems. AquaShield™ does not provide site design engineering or contractor services, but our staff can aid those parties as warranted. AquaShield™ does not operate a maintenance service but can assist stakeholders to make those arrangements with local service providers.

## 8.0 Field and Laboratory Testing Information and Analysis

### 8.A. *For Systems with 5-millimeter screening, any available field or laboratory testing information that demonstrates the System functionality and performance.*

**Appendix G** includes the AquaShield™ report titled *Laboratory Testing of the Aqua-Swirl® Stormwater Treatment System Model AS-3s for Trash Retention*. A full scale, commercially available Aqua-Swirl® Model AS-3s, which included a trash capture screen to trap particles 5.0 mm and greater, was tested in the presence of an independent observer to assess its capability of retaining trash commonly found in stormwater runoff. The trash composition was based on a specification cited in the report titled *Laboratory Testing of Gross Solids Removal Devices* prepared for CALTRANS by Dr. Bassam A. Young, Professor, Department of Civil and Environmental Engineering, UC Davis, May 2005, Report #CTSW-RT-05-73-18.1. Table 1 in the attached report lists the trash composition to include cardboard, cigarette butts, cloth, aluminum foil, plastic, Styrofoam, popsicle sticks and paper.

This testing program demonstrated 100% trash retention for three test runs at surface area loading rates of 21, 52 and 98 gpm/ft<sup>2</sup>. Photographs are included in the attached report to document the testing program and the trash inventory.

AquaShield™ considers that the Aqua-Swirl® as designed and tested meets the requirements of the CSWRCB's requirements for a Trash Treatment Control Device and can accordingly be listed as a Certified Trash Treatment Control Device.

### 8.B. *If the System does not include a 5-millimeter screen, adequate field or laboratory testing information that demonstrates the System captures trash particles of 5 millimeters or greater.*

Not applicable.



## APPENDIX A

**Aqua-Swirl® Polymer Coated Steel (PCS)  
Stormwater Treatment System**



**Projected View  
SCALE 1:80**

Unless other traffic barriers are present, bollards shall be placed around access riser(s) in non-traffic areas to prevent inadvertent loading by maintenance vehicles.

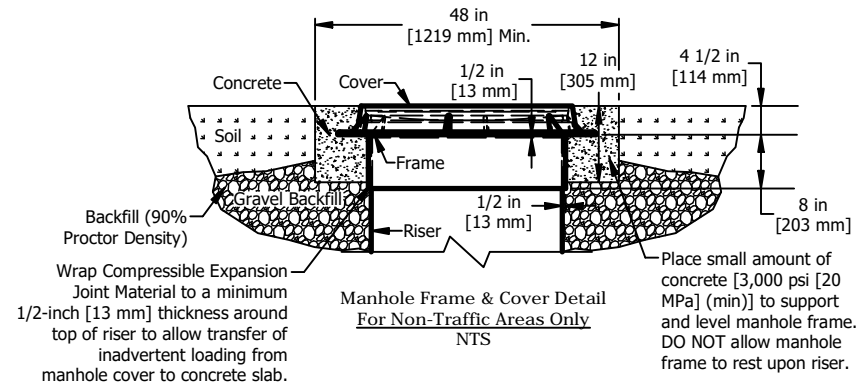

If traffic loading (HS-25) is required or anticipated, a 4-foot [1.22 m] diameter, 14-inch [356 mm] thick reinforced concrete pad must be placed over the Stormwater Treatment System Riser to support and level the manhole frame, as shown. The top of riser pipe must be wrapped with compressible expansion joint material to a minimum 1/2-inch [13 mm] thickness to allow transfer of wheel loads from manhole cover to concrete slab. Manhole cover shall bear on concrete slab and not on riser pipe. The concrete slab shall have a minimum strength of 3,000 psi [20 MPa] and be reinforced with #4 [13 mm] reinforcing steel as shown. Minimum cover over reinforcing steel shall be 1-inch [25 mm]. Top of manhole cover and concrete slab shall be level with finish grade.

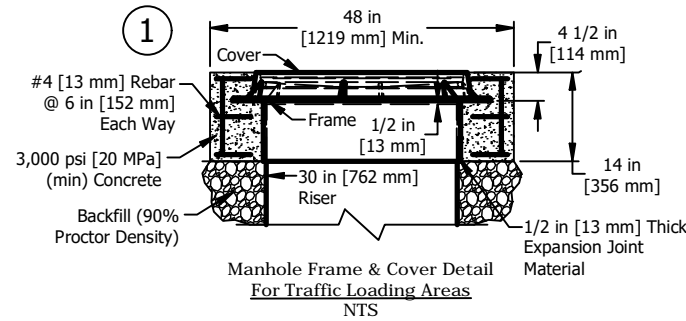

Please see accompanied Aqua-Swirl® specification notes. See Site Plan for actual system orientation. Approximate dry (pick) weight: 1000 lbs [500 kg].

- ① As an alternative, 42 in [1067 mm] diameter, HS-20/25 rated precast concrete rings may be substituted. 14 in [356 mm] thickness must be maintained.
- ② AS-2s BYP inlet/outlet pipe size ranges from 8 in [203 mm] to 15 in [381 mm].
- ③ AS-2s chamber height may vary from 52 in [1321 mm] to 60 in [1524 mm], depending on inlet/outlet pipe size.
- ④ Orientation may vary from a minimum of 90° to a maximum of 180°.

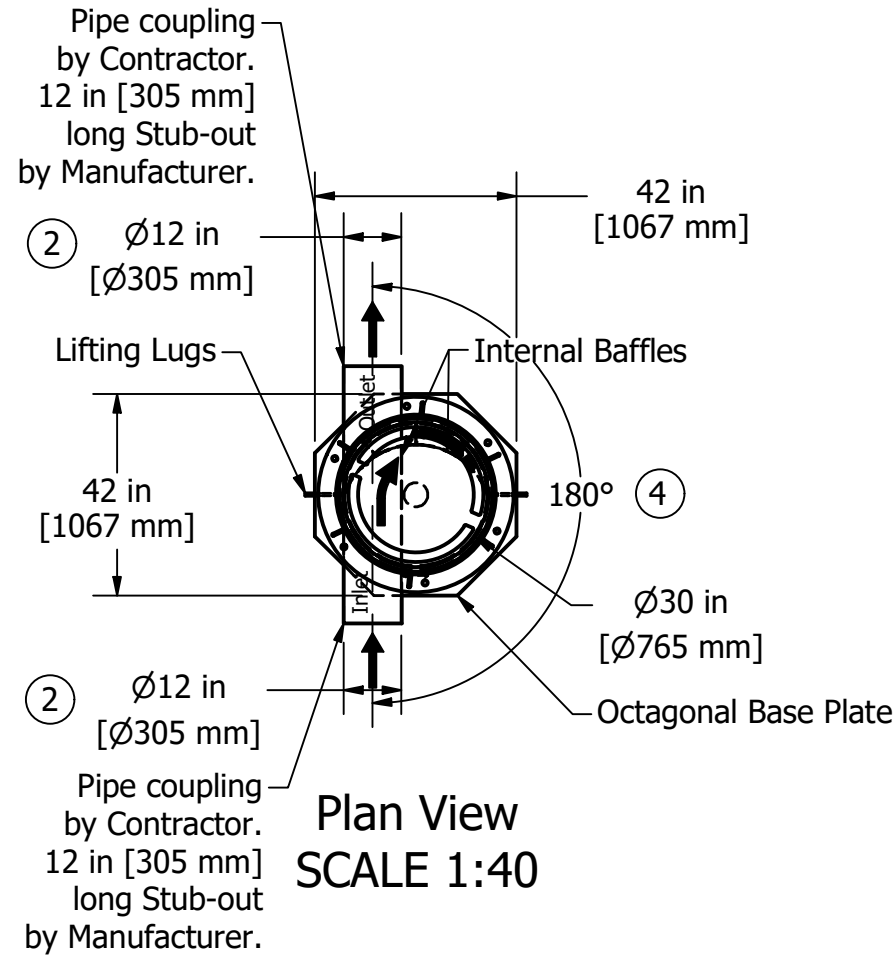

**Plan View  
SCALE 1:40**

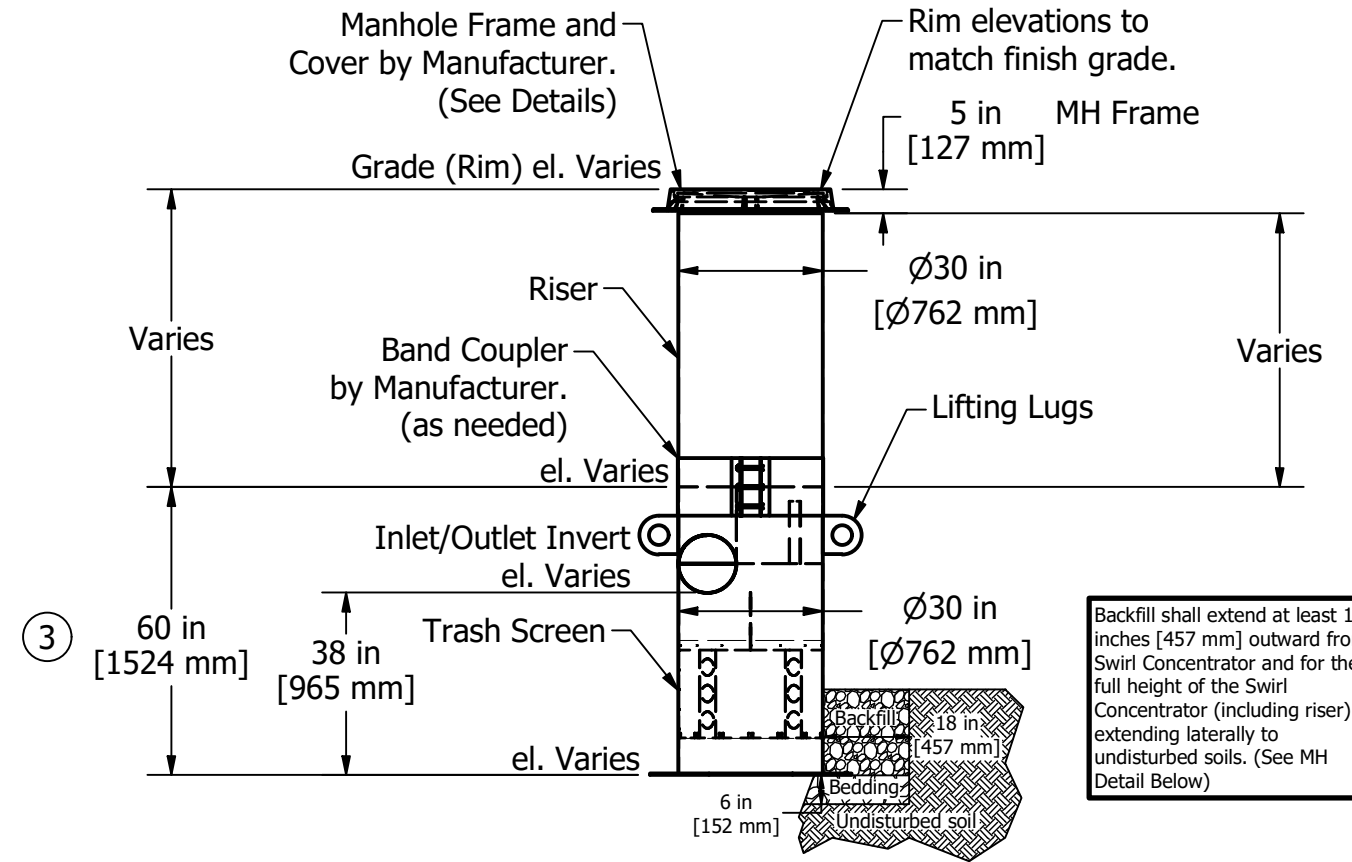

**Elevation View  
SCALE 1:40**

**Aqua-Swirl® Polymer Coated Steel (PCS)  
Stormwater Treatment System**



**Projected View  
SCALE 1:80**

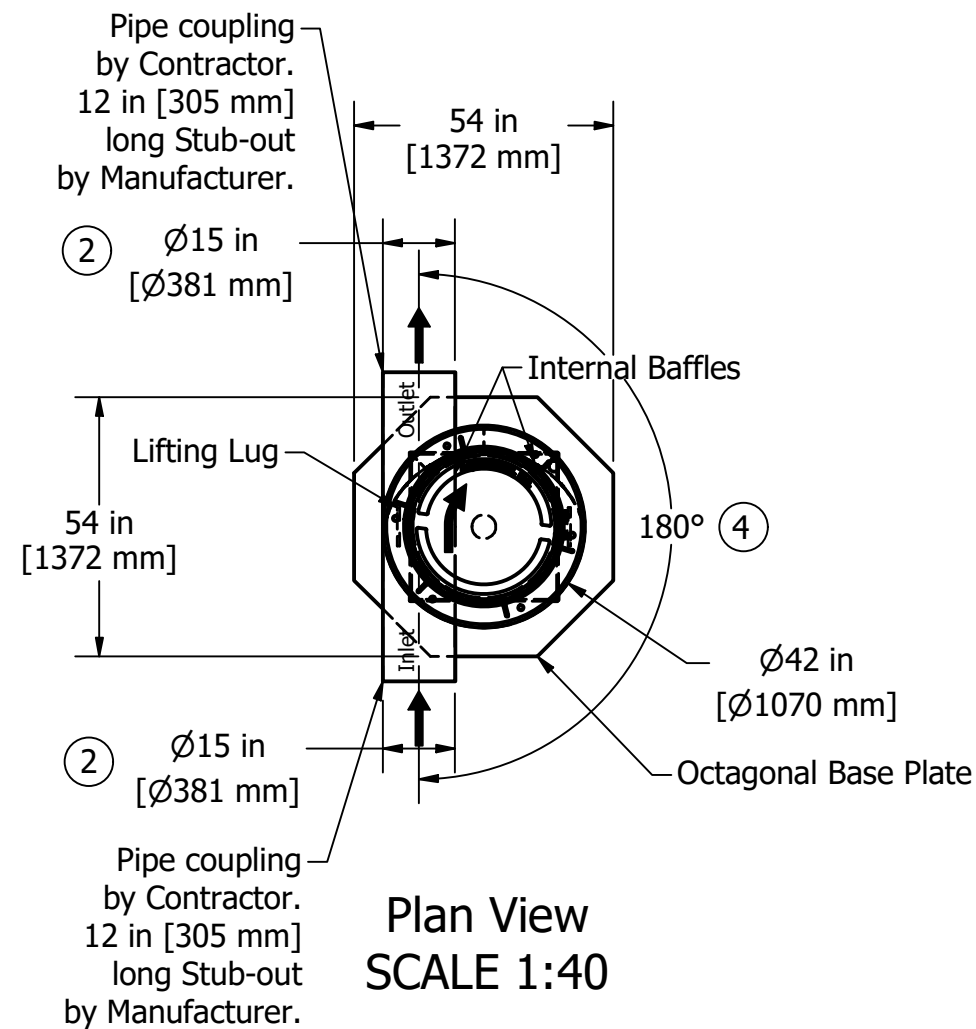

Unless other traffic barriers are present, bollards shall be placed around access riser(s) in non-traffic areas to prevent inadvertent loading by maintenance vehicles.

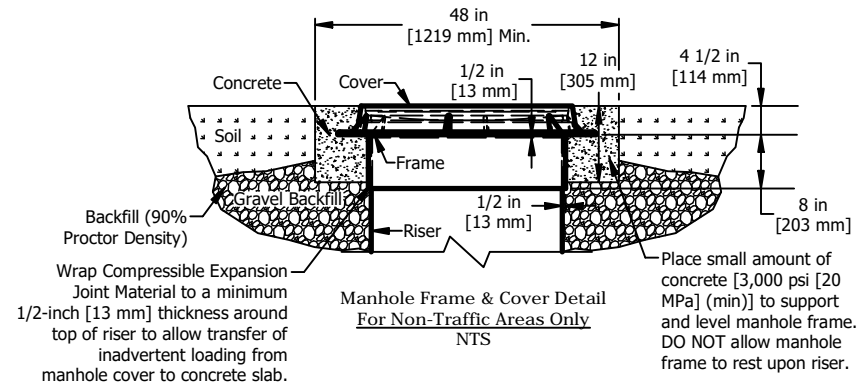

If traffic loading (HS-25) is required or anticipated, a 4-foot [1.22 m] diameter, 14-inch [356 mm] thick reinforced concrete pad must be placed over the Stormwater Treatment System Riser to support and level the manhole frame, as shown. The top of riser pipe must be wrapped with compressible expansion joint material to a minimum 1/2-inch [13 mm] thickness to allow transfer of wheel loads from manhole cover to concrete slab. Manhole cover shall bear on concrete slab and not on riser pipe. The concrete slab shall have a minimum strength of 3,000 psi [20 MPa] and be reinforced with #4 [13 mm] reinforcing steel as shown. Minimum cover over reinforcing steel shall be 1-inch [25 mm]. Top of manhole cover and concrete slab shall be level with finish grade.

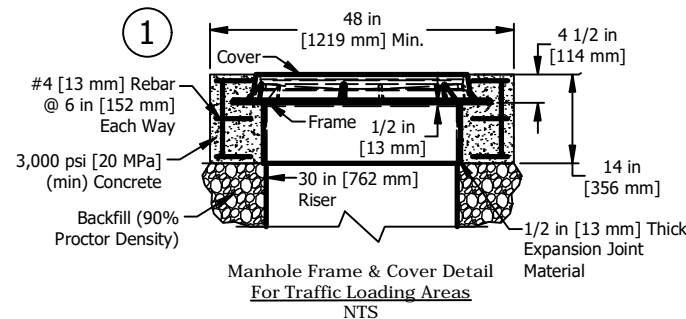

Please see accompanied Aqua-Swirl® specification notes. See Site Plan for actual system orientation. Approximate dry (pick) weight: 1500 lbs [700 kg].

- ① As an alternative, 42 in [1067 mm] diameter, HS-20/25 rated precast concrete rings may be substituted. 14 in [356 mm] thickness must be maintained.
- ② AS-3s BYP inlet/outlet pipe size ranges from 10 in [254 mm] to 21 in [533 mm].
- ③ AS-3s chamber height may vary from 90 in [2286 mm] to 104 in [2642 mm], depending on inlet/outlet pipe size.
- ④ Orientation may vary from a minimum of 90° to a maximum of 180°.

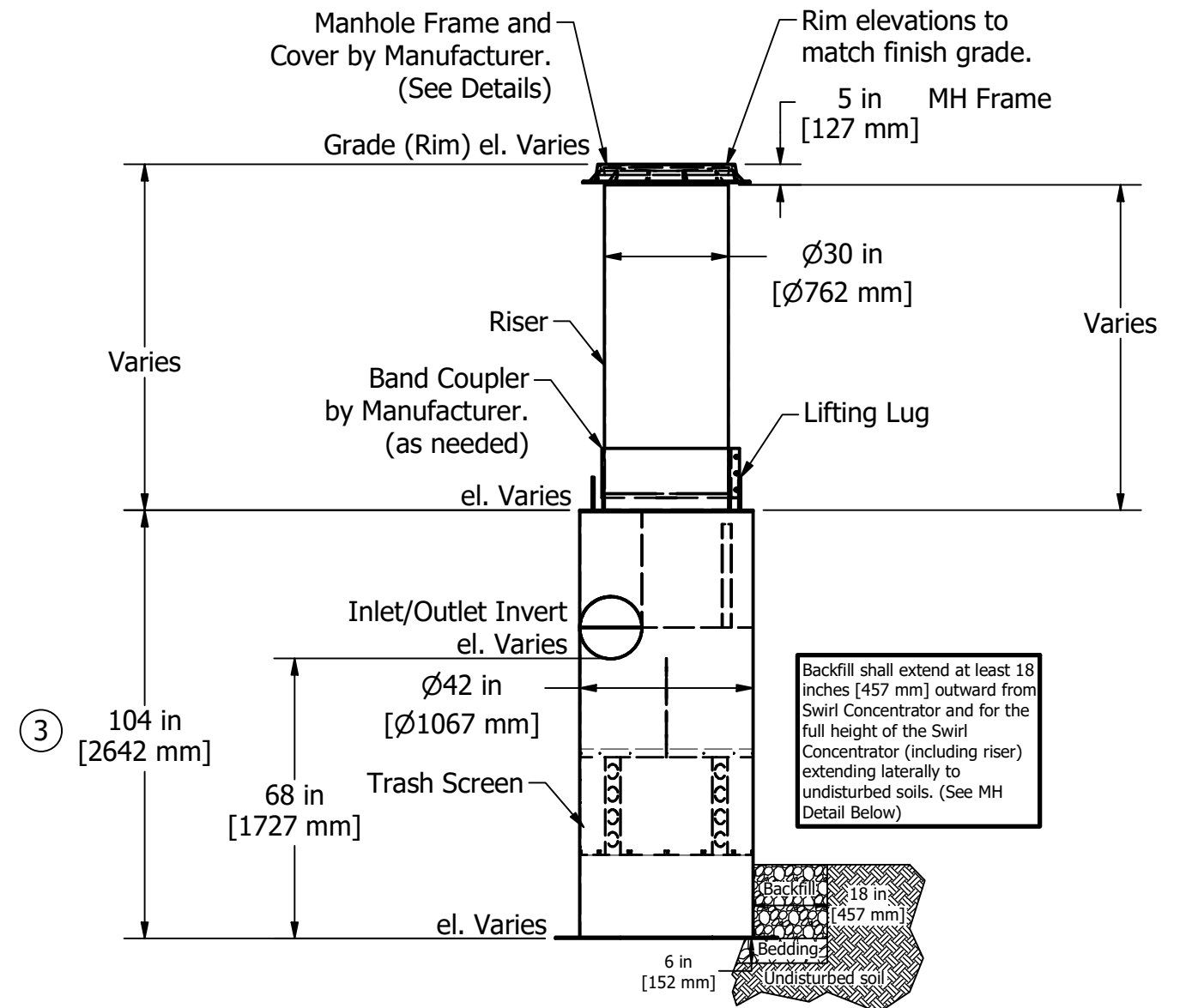

**Aqua-Swirl® Polymer Coated Steel (PCS)  
Stormwater Treatment System**

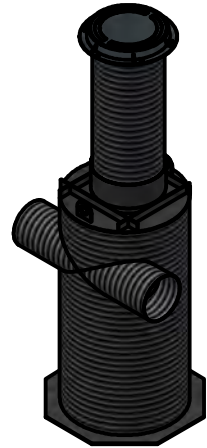

**Projected View  
SCALE 1:80**

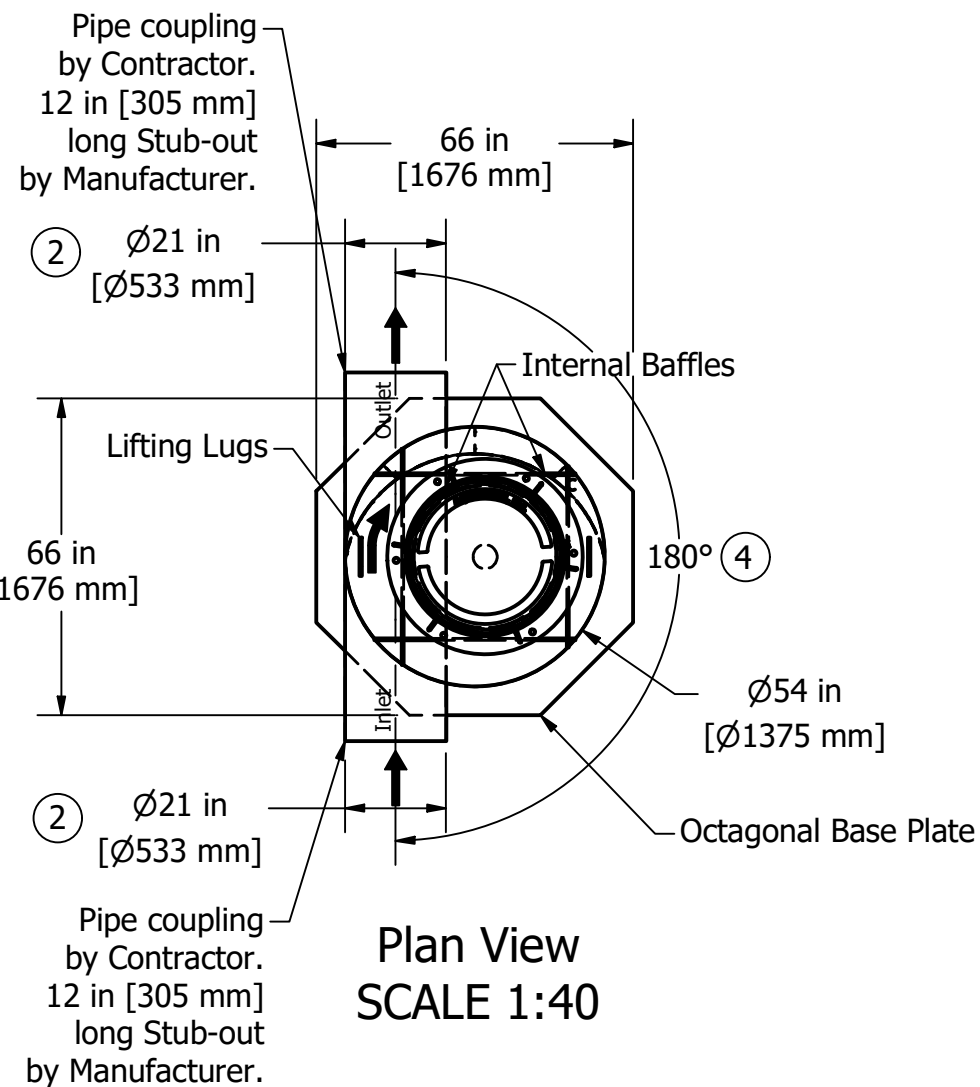

Unless other traffic barriers are present, bollards shall be placed around access riser(s) in non-traffic areas to prevent inadvertent loading by maintenance vehicles.

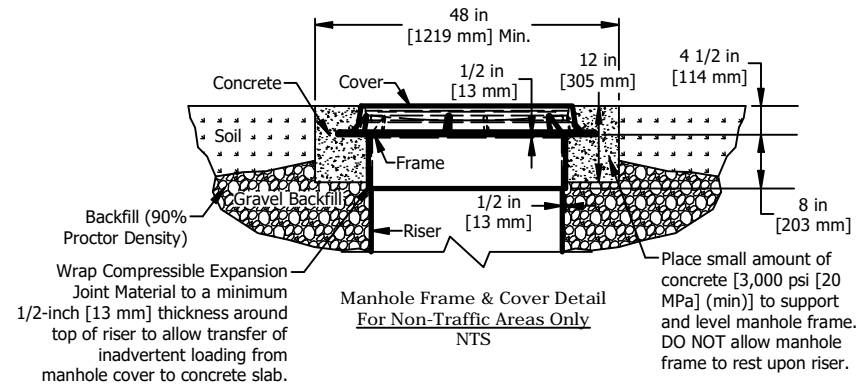

If traffic loading (HS-25) is required or anticipated, a 4-foot [1.22 m] diameter, 14-inch [356 mm] thick reinforced concrete pad must be placed over the Stormwater Treatment System Riser to support and level the manhole frame, as shown. The top of riser pipe must be wrapped with compressible expansion joint material to a minimum 1/2-inch [13 mm] thickness to allow transfer of wheel loads from manhole cover to concrete slab. Manhole cover shall bear on concrete slab and not on riser pipe. The concrete slab shall have a minimum strength of 3,000 psi [20 MPa] and be reinforced with #4 [13 mm] reinforcing steel as shown. Minimum cover over reinforcing steel shall be 1-inch [25 mm]. Top of manhole cover and concrete slab shall be level with finish grade.

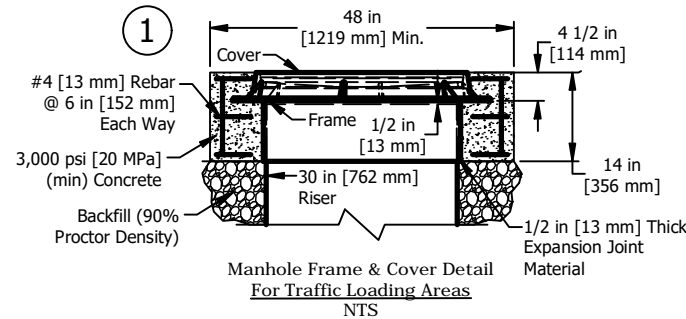

Please see accompanied Aqua-Swirl® specification notes. See Site Plan for actual system orientation. Approximate dry (pick) weight: 2000 lbs [900 kg].

- (1) As an alternative, 42 in [1067 mm] diameter, HS-20/25 rated precast concrete rings may be substituted. 14 in [356 mm] thickness must be maintained.
- (2) AS-4s BYP inlet/outlet pipe size ranges from 12 in [305 mm] to 27 in [686 mm].
- (3) AS-4s chamber height may vary from 92 in [2337 mm] to 107 in [2718 mm], depending on inlet/outlet pipe size.
- (4) Orientation may vary from a minimum of 90° to a maximum of 180°.

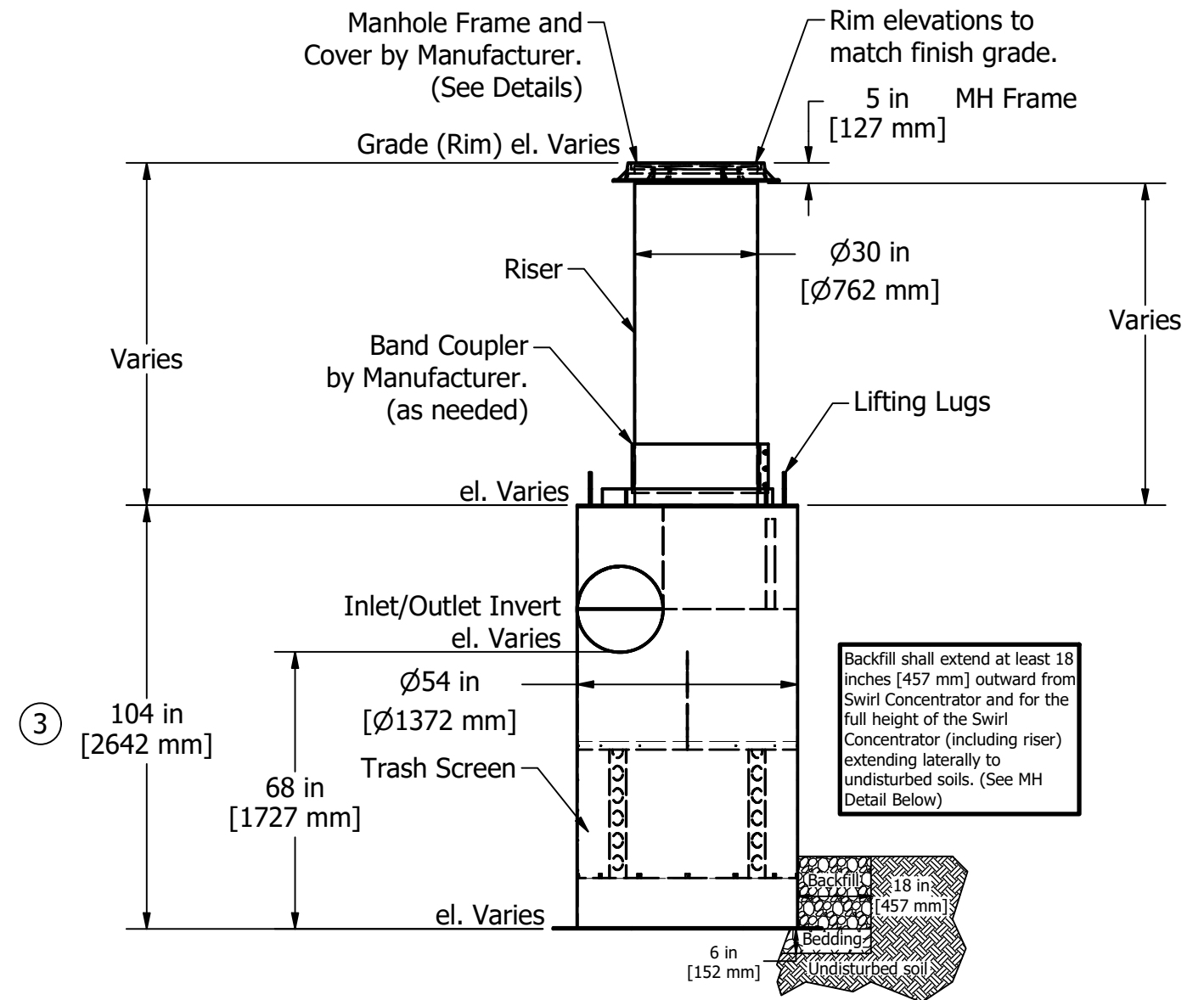



**Aqua-Swirl® Polymer Coated Steel (PCS)  
Stormwater Treatment System**

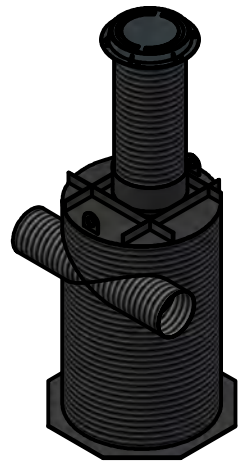

**Projected View  
SCALE 1:80**

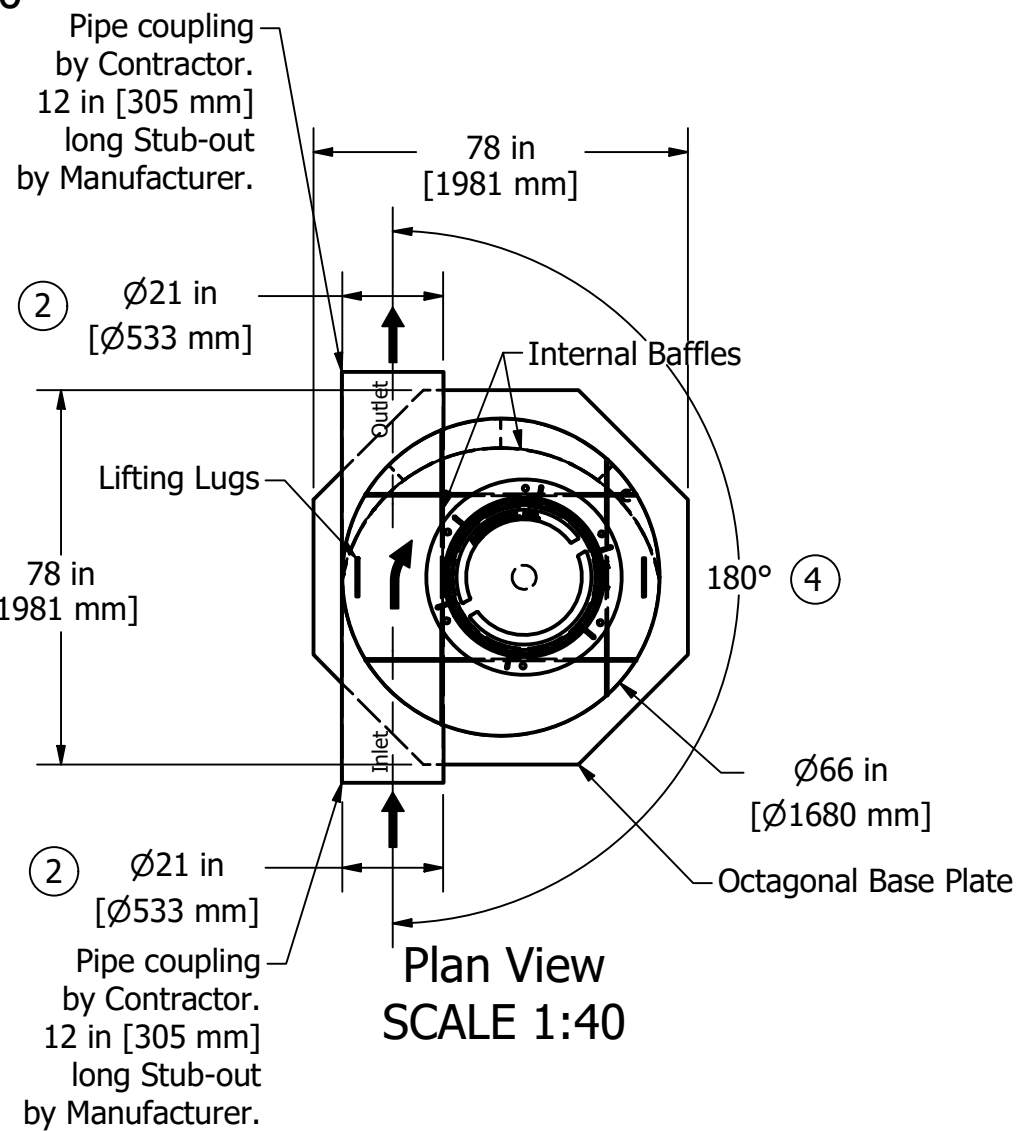

Unless other traffic barriers are present, bollards shall be placed around access riser(s) in non-traffic areas to prevent inadvertent loading by maintenance vehicles.

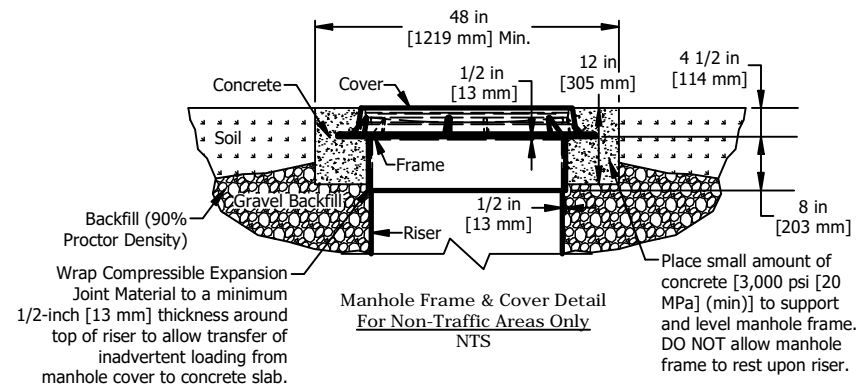

If traffic loading (HS-25) is required or anticipated, a 4-foot [1.22 m] diameter, 14-inch [356 mm] thick reinforced concrete pad must be placed over the Stormwater Treatment System Riser to support and level the manhole frame, as shown. The top of riser pipe must be wrapped with compressible expansion joint material to a minimum 1/2-inch [13 mm] thickness to allow transfer of wheel loads from manhole cover to concrete slab. Manhole cover shall bear on concrete slab and not on riser pipe. The concrete slab shall have a minimum strength of 3,000 psi [20 MPa] and be reinforced with #4 [13 mm] reinforcing steel as shown. Minimum cover over reinforcing steel shall be 1-inch [25 mm]. Top of manhole cover and concrete slab shall be level with finish grade.

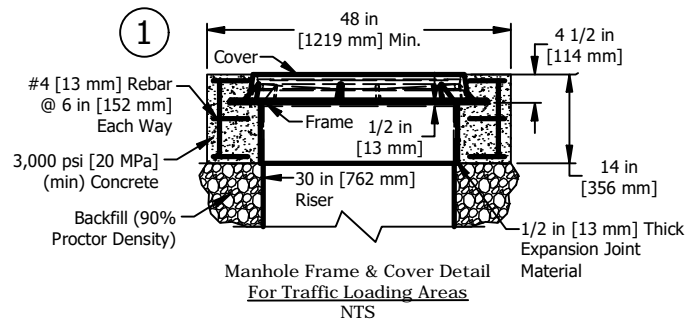

Please see accompanied Aqua-Swirl® specification notes. See Site Plan for actual system orientation. Approximate dry (pick) weight: 2200 lbs [1000 kg].

- ① As an alternative, 42 in [1067 mm] diameter, HS-20/25 rated precast concrete rings may be substituted. 14 in [356 mm] thickness must be maintained.
- ② AS-5s BYP inlet/outlet pipe size ranges from 12 in [305 mm] to 30 in [762 mm].
- ③ AS-5s chamber height may vary from 92 in [2337 mm] to 110 in [2794 mm], depending on inlet/outlet pipe size.
- ④ Orientation may vary from a minimum of 90° to a maximum of 180°.

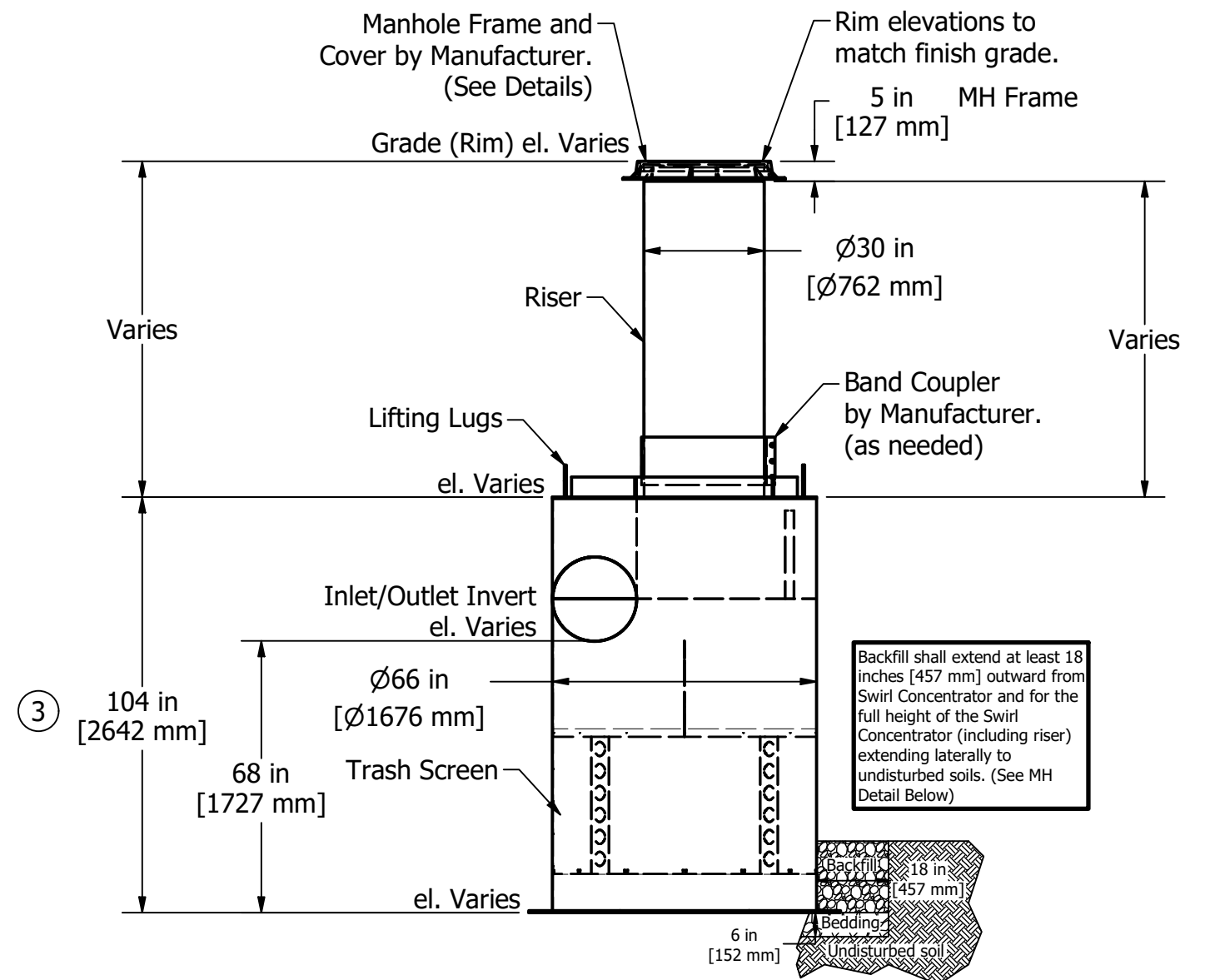

**Aqua-Swirl® Polymer Coated Steel (PCS)  
Stormwater Treatment System**

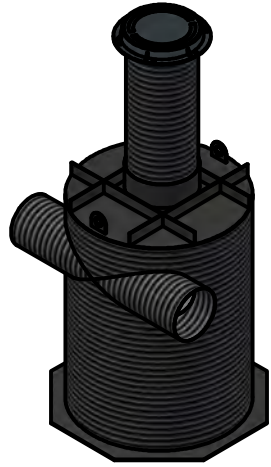

**Projected View  
SCALE 1:80**

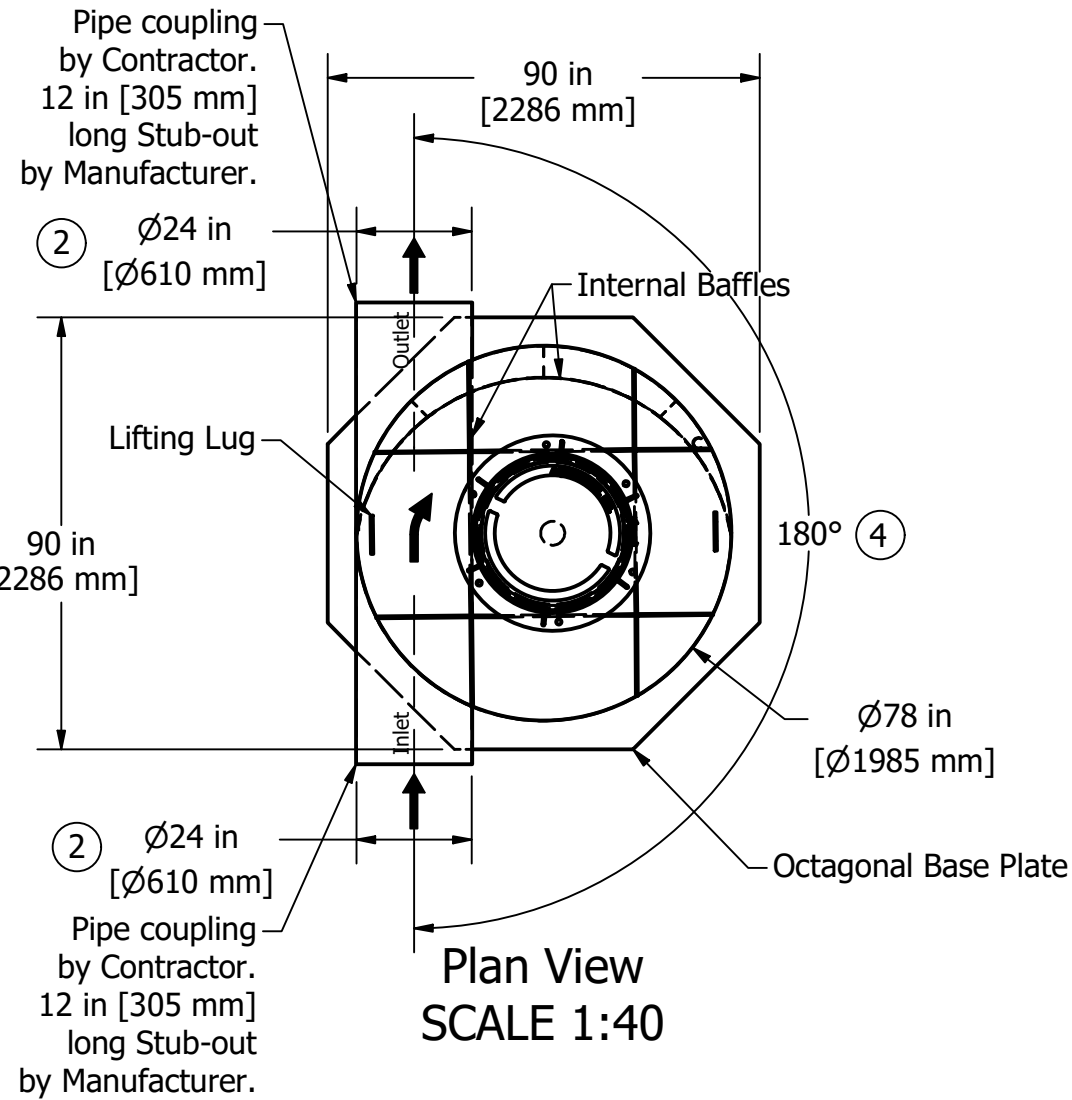

Unless other traffic barriers are present, bollards shall be placed around access riser(s) in non-traffic areas to prevent inadvertent loading by maintenance vehicles.

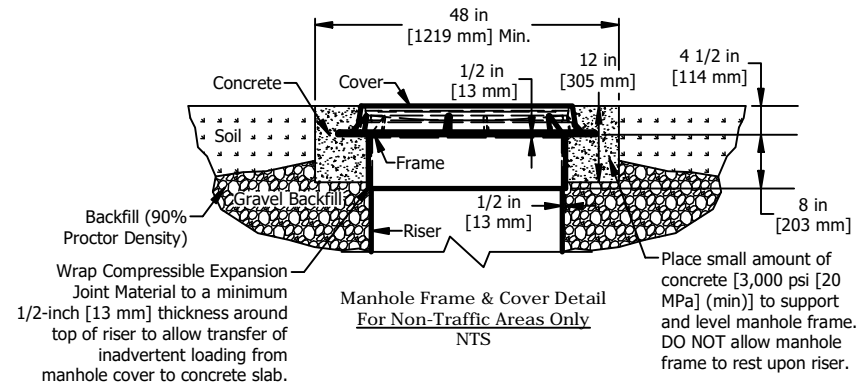

If traffic loading (HS-25) is required or anticipated, a 4-foot [1.22 m] diameter, 14-inch [356 mm] thick reinforced concrete pad must be placed over the Stormwater Treatment System Riser to support and level the manhole frame, as shown. The top of riser pipe must be wrapped with compressible expansion joint material to a minimum 1/2-inch [13 mm] thickness to allow transfer of wheel loads from manhole cover to concrete slab. Manhole cover shall bear on concrete slab and not on riser pipe. The concrete slab shall have a minimum strength of 3,000 psi [20 MPa] and be reinforced with #4 [13 mm] reinforcing steel as shown. Minimum cover over reinforcing steel shall be 1-inch [25 mm]. Top of manhole cover and concrete slab shall be level with finish grade.

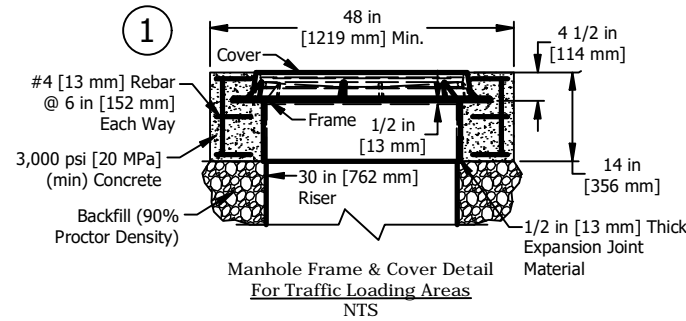

Please see accompanied Aqua-Swirl® specification notes. See Site Plan for actual system orientation. Approximate dry (pick) weight: 3000 lbs [1400 kg].

- ① As an alternative, 42 in [1067 mm] diameter, HS-20/25 rated precast concrete rings may be substituted. 14 in [356 mm] thickness must be maintained.
- ② AS-6s BYP inlet/outlet pipe size ranges from 15 in [381 mm] to 36 in [914 mm].
- ③ AS-6s chamber height may vary from 95 in [2413 mm] to 116 in [2946 mm], depending on inlet/outlet pipe size.
- ④ Orientation may vary from a minimum of 90° to a maximum of 180°.

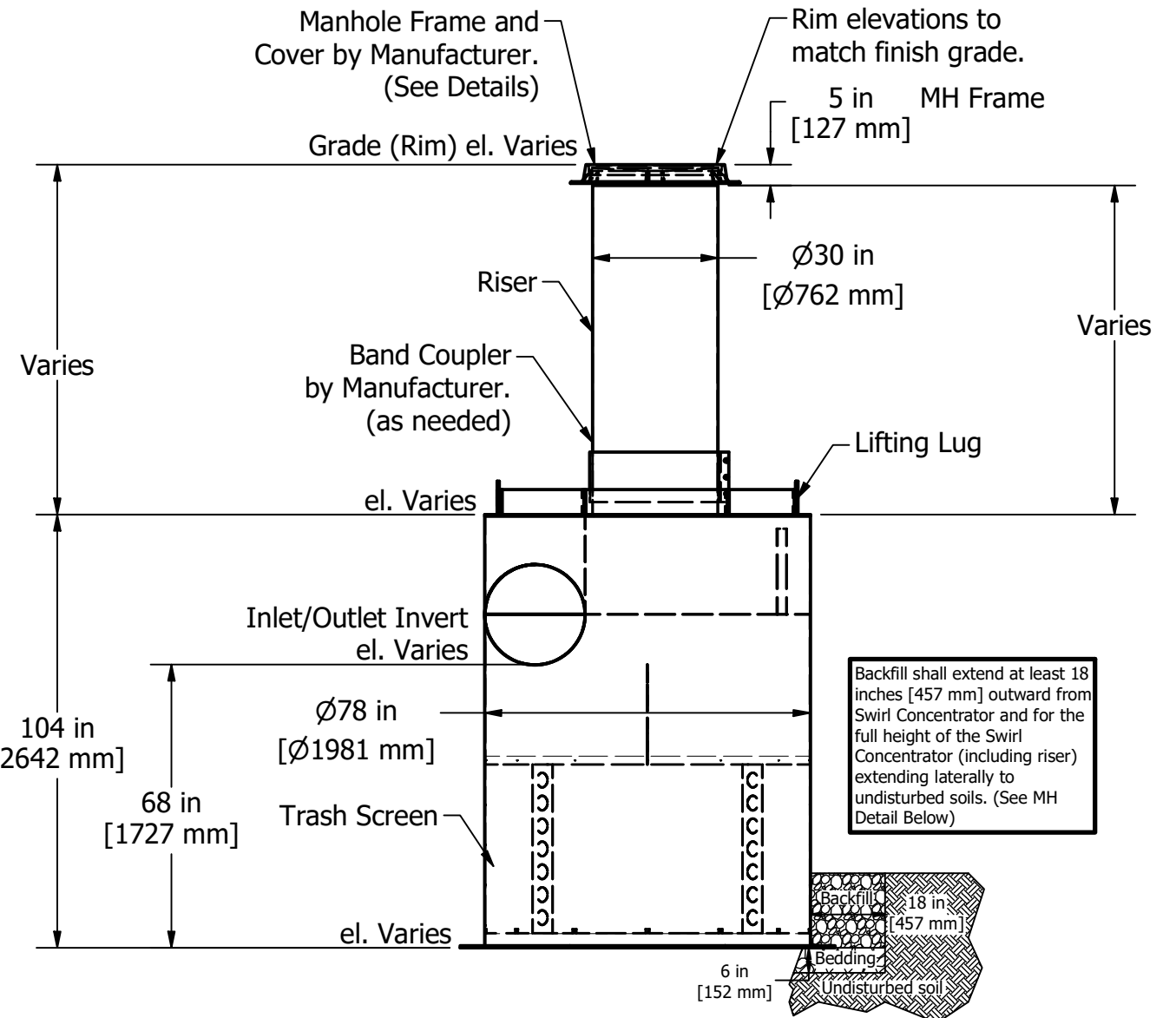

**Aqua-Swirl® Polymer Coated Steel (PCS)  
Stormwater Treatment System**

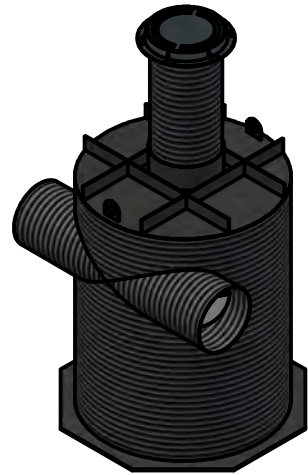

**Projected View  
SCALE 1:80**

Unless other traffic barriers are present, bollards shall be placed around access riser(s) in non-traffic areas to prevent inadvertent loading by maintenance vehicles.

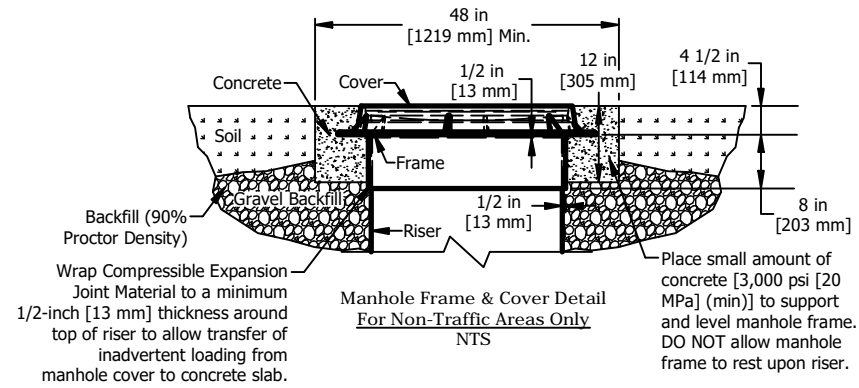

If traffic loading (HS-25) is required or anticipated, a 4-foot [1.22 m] diameter, 14-inch [356 mm] thick reinforced concrete pad must be placed over the Stormwater Treatment System Riser to support and level the manhole frame, as shown. The top of riser pipe must be wrapped with compressible expansion joint material to a minimum 1/2-inch [13 mm] thickness to allow transfer of wheel loads from manhole cover to concrete slab. Manhole cover shall bear on concrete slab and not on riser pipe. The concrete slab shall have a minimum strength of 3,000 psi [20 MPa] and be reinforced with #4 [13 mm] reinforcing steel as shown. Minimum cover over reinforcing steel shall be 1-inch [25 mm]. Top of manhole cover and concrete slab shall be level with finish grade.

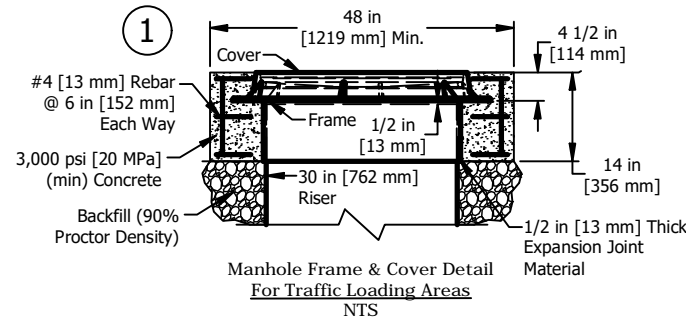

Please see accompanied Aqua-Swirl® specification notes. See Site Plan for actual system orientation. Approximate dry (pick) weight: 3800 lbs [1700 kg].

- ① As an alternative, 42 in [1067 mm] diameter, HS-20/25 rated precast concrete rings may be substituted. 14 in [356 mm] thickness must be maintained.
- ② AS-7s BYP inlet/outlet pipe size ranges from 15 in [381 mm] to 42 in [1067 mm].
- ③ AS-7s chamber height may vary from 95 in [2413 mm] to 122 in [3099 mm], depending on inlet/outlet pipe size.
- ④ Orientation may vary from a minimum of 90° to a maximum of 180°.

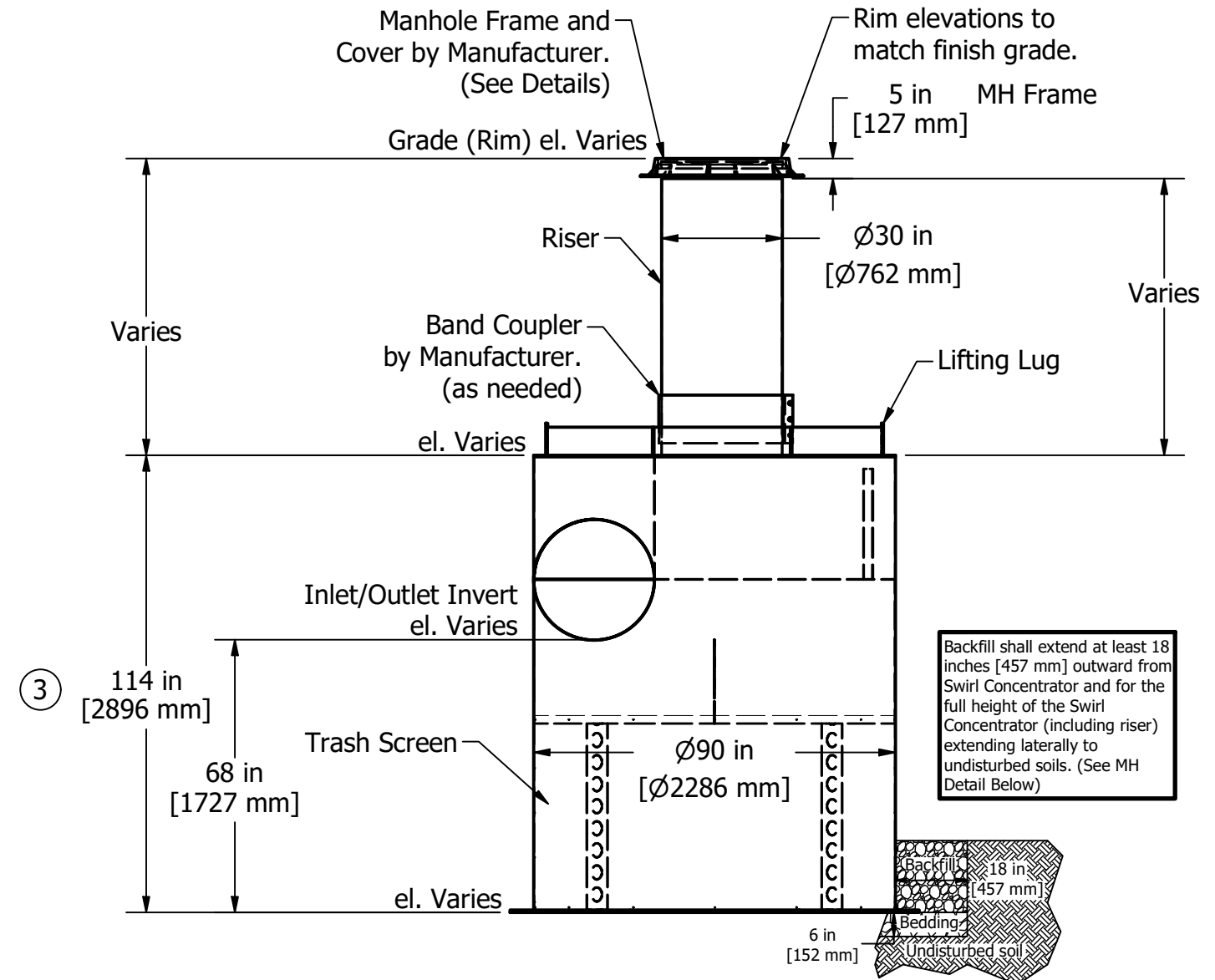
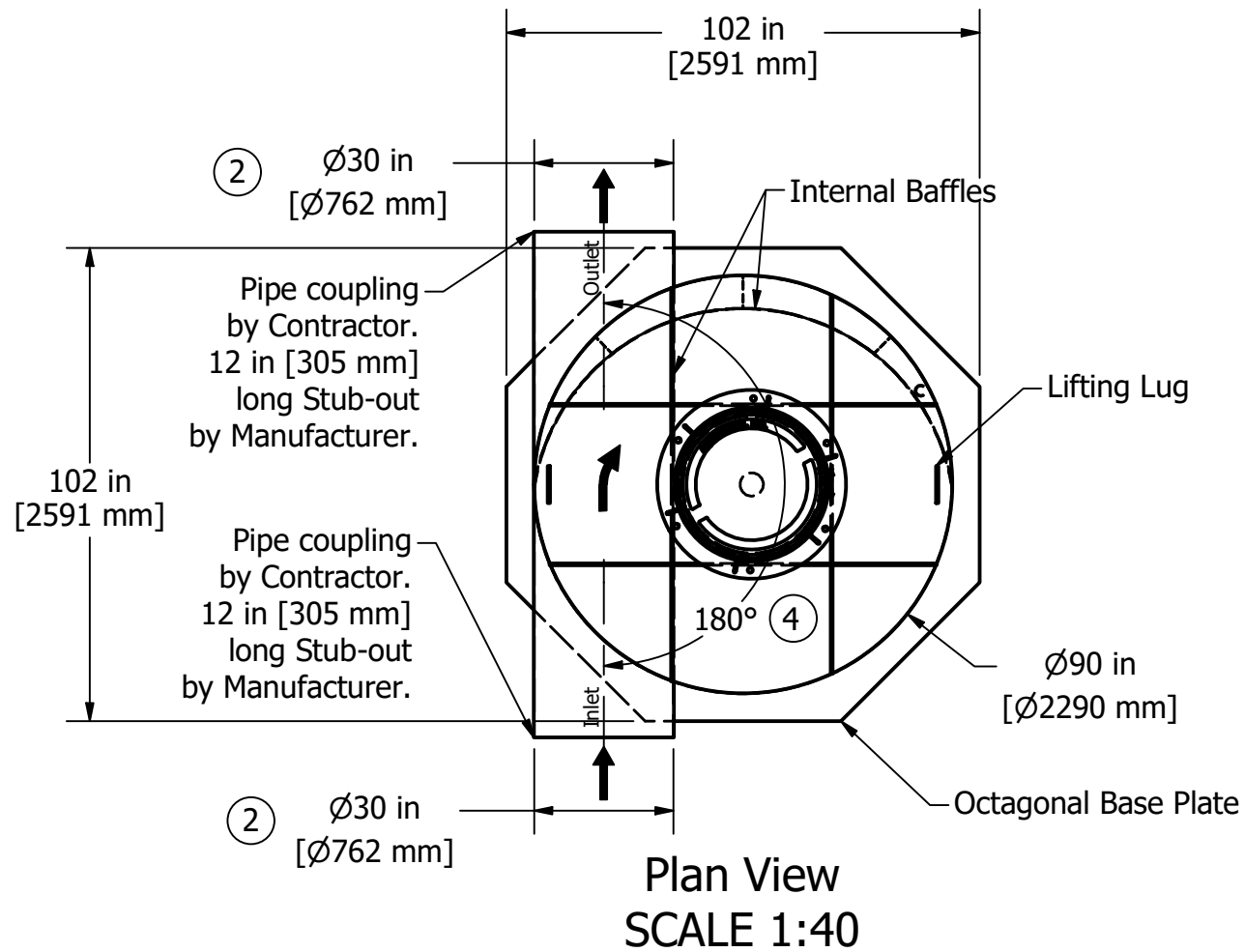

Backfill shall extend at least 18 inches [457 mm] outward from Swirl Concentrator and for the full height of the Swirl Concentrator (including riser) extending laterally to undisturbed soils. (See MH Detail Below)



**Aqua-Swirl® Polymer Coated Steel (PCS)  
Stormwater Treatment System**

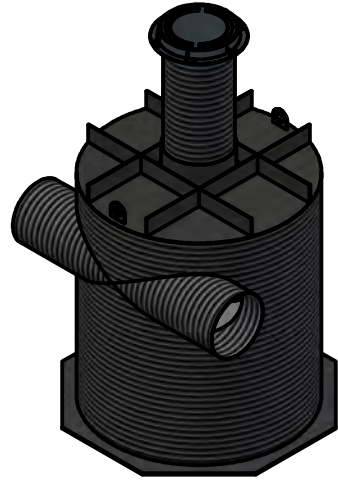

**Projected View  
SCALE 1:80**

Unless other traffic barriers are present, bollards shall be placed around access riser(s) in non-traffic areas to prevent inadvertent loading by maintenance vehicles.

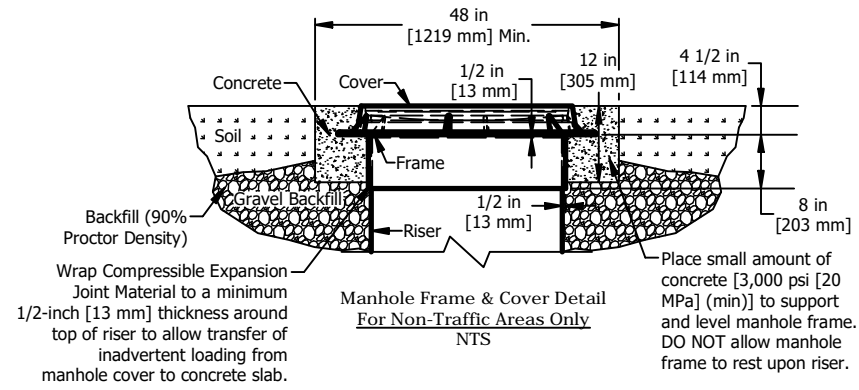

If traffic loading (HS-25) is required or anticipated, a 4-foot [1.22 m] diameter, 14-inch [356 mm] thick reinforced concrete pad must be placed over the Stormwater Treatment System Riser to support and level the manhole frame, as shown. The top of riser pipe must be wrapped with compressible expansion joint material to a minimum 1/2-inch [13 mm] thickness to allow transfer of wheel loads from manhole cover to concrete slab. Manhole cover shall bear on concrete slab and not on riser pipe. The concrete slab shall have a minimum strength of 3,000 psi [20 MPa] and be reinforced with #4 [13 mm] reinforcing steel as shown. Minimum cover over reinforcing steel shall be 1-inch [25 mm]. Top of manhole cover and concrete slab shall be level with finish grade.

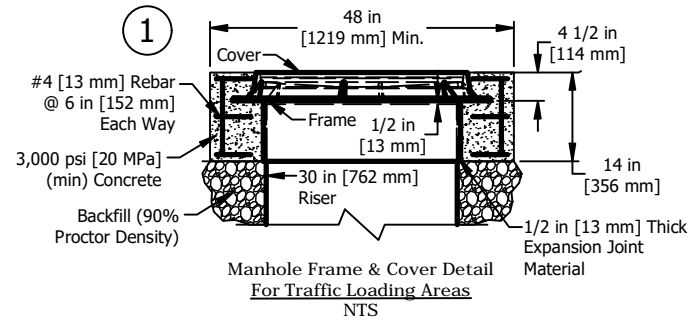

Please see accompanied Aqua-Swirl® specification notes. See Site Plan for actual system orientation. Approximate dry (pick) weight: 5000 lbs [2300 kg].

- ① As an alternative, 42 in [1067 mm] diameter, HS-20/25 rated precast concrete rings may be substituted. 14 in [356 mm] thickness must be maintained.
- ② AS-8s BYP inlet/outlet pipe size ranges from 18 in [457 mm] to 48 in [1219 mm].
- ③ AS-8s chamber height may vary from 98 in [2489 mm] to 128 in [3251 mm], depending on inlet/outlet pipe size.
- ④ Orientation may vary from a minimum of 90° to a maximum of 180°.

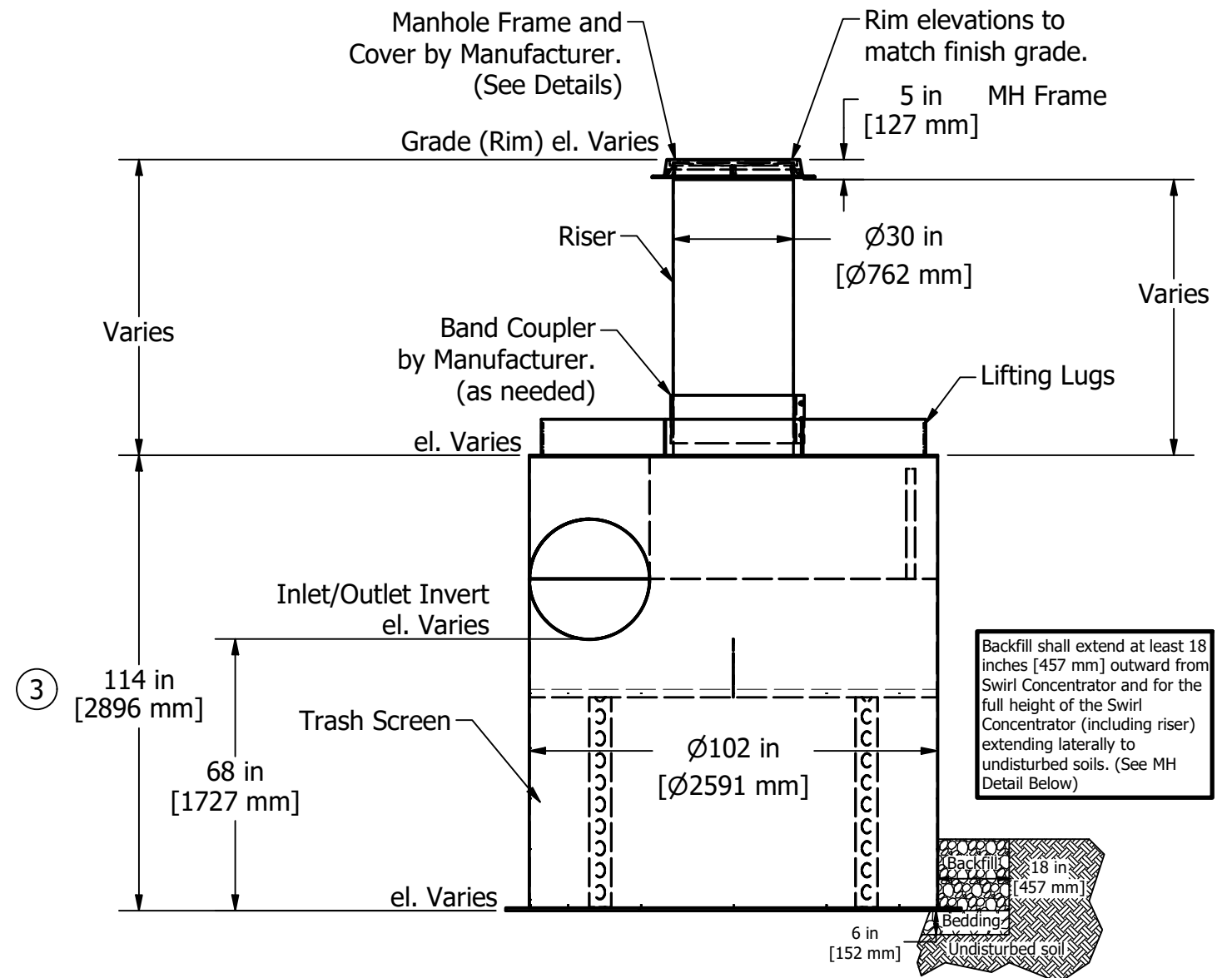
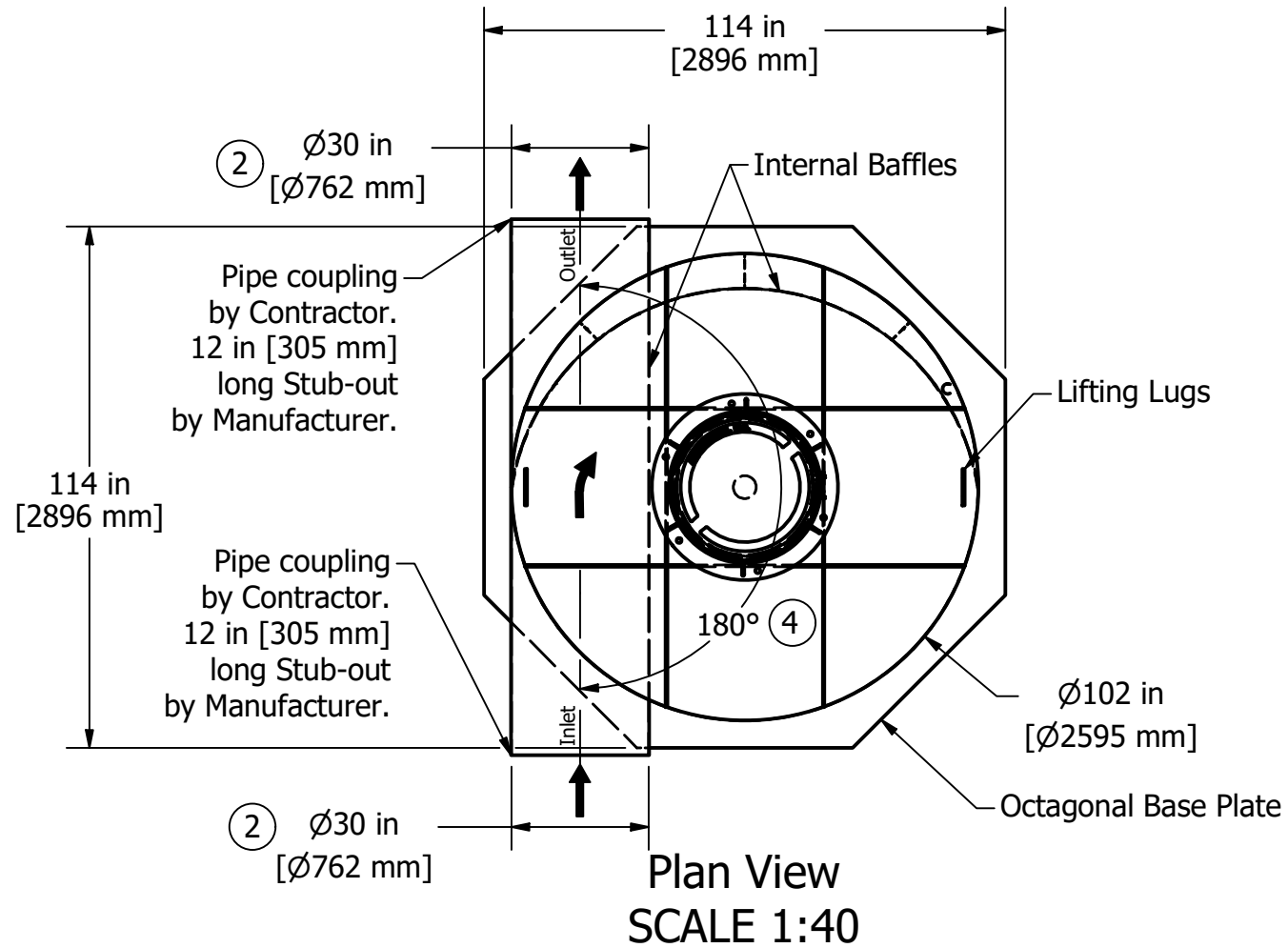



**Aqua-Swirl® Polymer Coated Steel (PCS)  
Stormwater Treatment System**

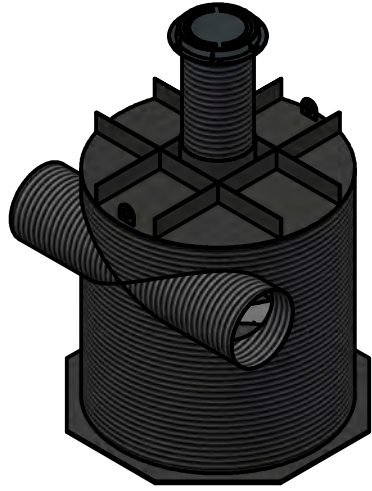

**Projected View  
SCALE 1:80**

Unless other traffic barriers are present, bollards shall be placed around access riser(s) in non-traffic areas to prevent inadvertent loading by maintenance vehicles.

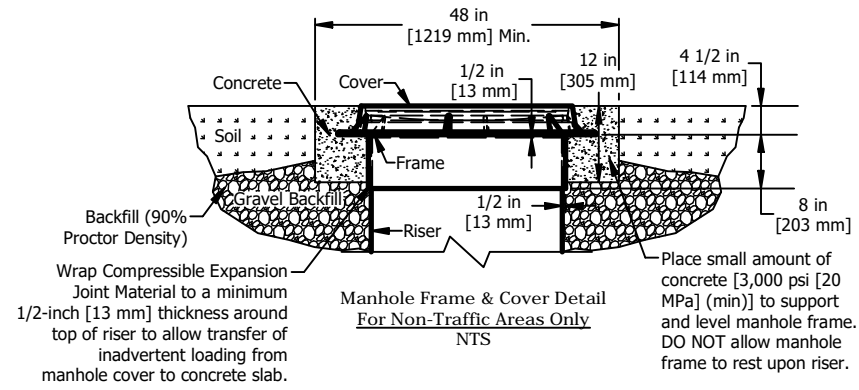

If traffic loading (HS-25) is required or anticipated, a 4-foot [1.22 m] diameter, 14-inch [356 mm] thick reinforced concrete pad must be placed over the Stormwater Treatment System Riser to support and level the manhole frame, as shown. The top of riser pipe must be wrapped with compressible expansion joint material to a minimum 1/2-inch [13 mm] thickness to allow transfer of wheel loads from manhole cover to concrete slab. Manhole cover shall bear on concrete slab and not on riser pipe. The concrete slab shall have a minimum strength of 3,000 psi [20 MPa] and be reinforced with #4 [13 mm] reinforcing steel as shown. Minimum cover over reinforcing steel shall be 1-inch [25 mm]. Top of manhole cover and concrete slab shall be level with finish grade.

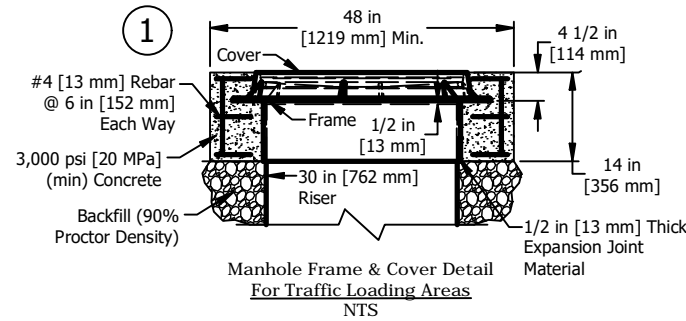

Please see accompanied Aqua-Swirl® specification notes. See Site Plan for actual system orientation. Approximate dry (pick) weight: 5900 lbs [2700 kg].

- ① As an alternative, 42 in [1067 mm] diameter, HS-20/25 rated precast concrete rings may be substituted. 14 in [356 mm] thickness must be maintained.
- ② AS-9s BYP inlet/outlet pipe size ranges from 21 in [533 mm] to 54 in [1372 mm].
- ③ AS-9s chamber height may vary from 101 in [2565 mm] to 134 in [3404 mm], depending on inlet/outlet pipe size.
- ④ Orientation may vary from a minimum of 90° to a maximum of 180°.

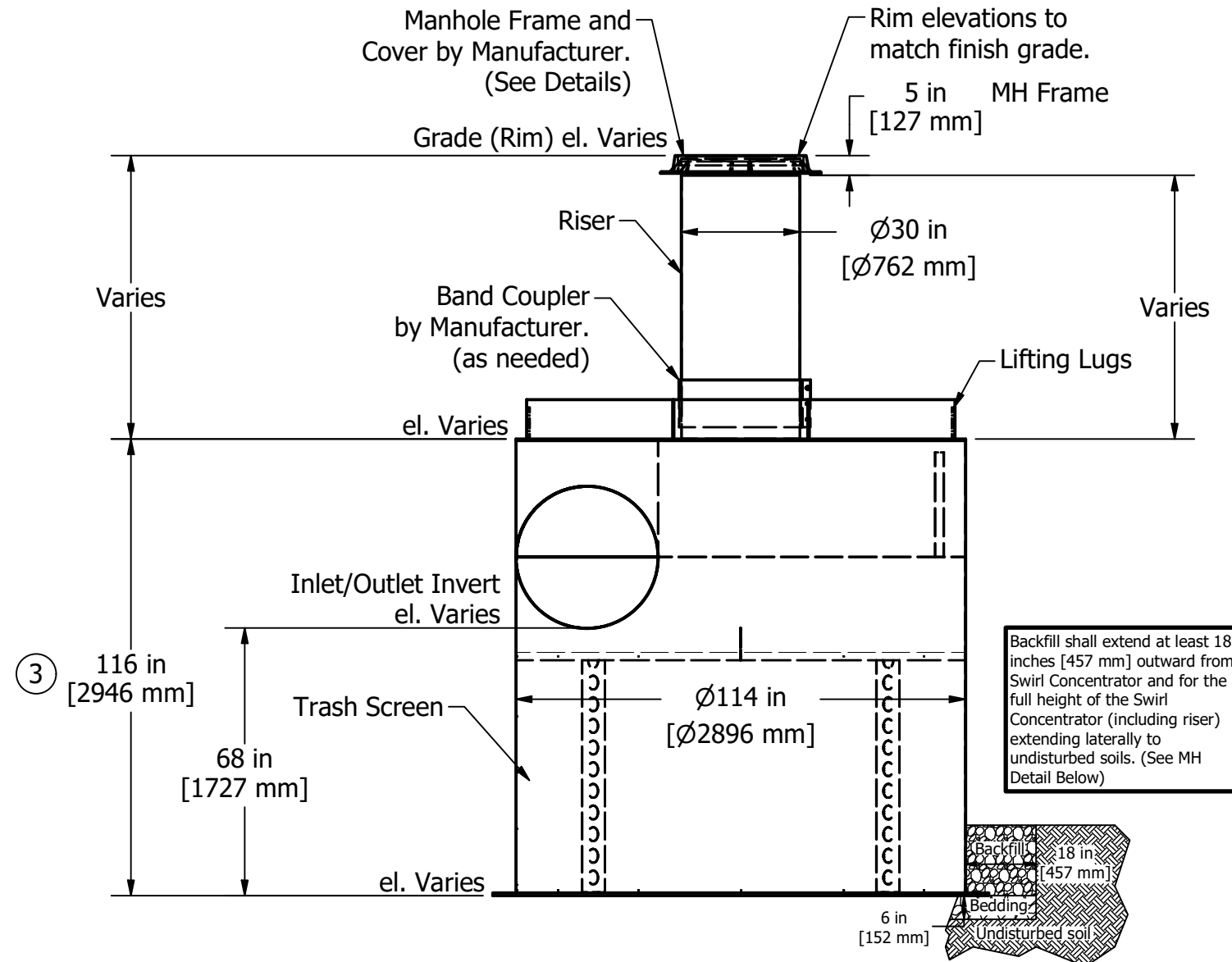
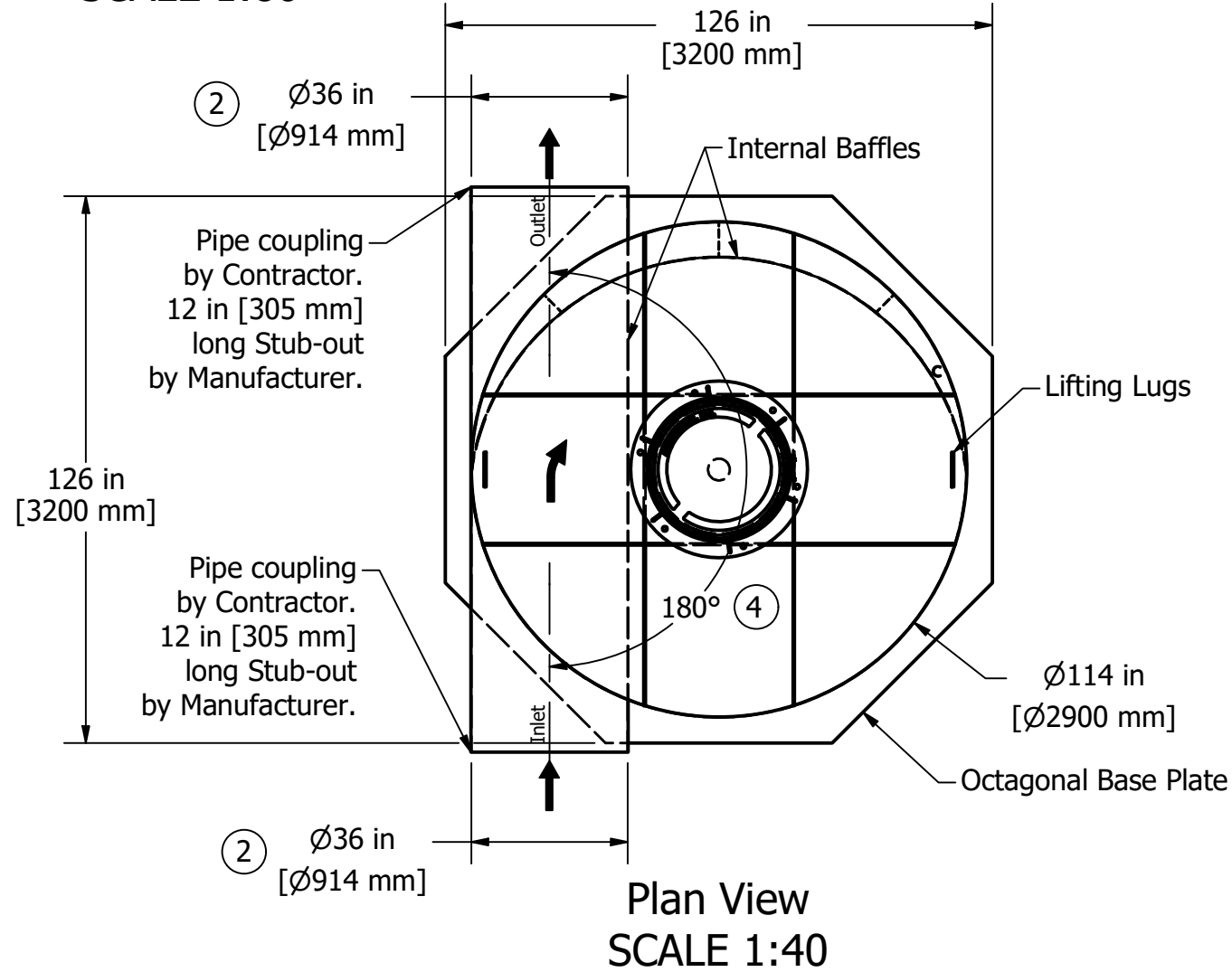

**Aqua-Swirl® Polymer Coated Steel (PCS)  
Stormwater Treatment System**

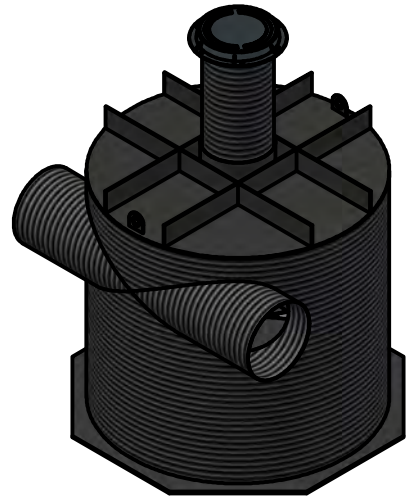

**Projected View  
SCALE 1:80**

Unless other traffic barriers are present, bollards shall be placed around access riser(s) in non-traffic areas to prevent inadvertent loading by maintenance vehicles.

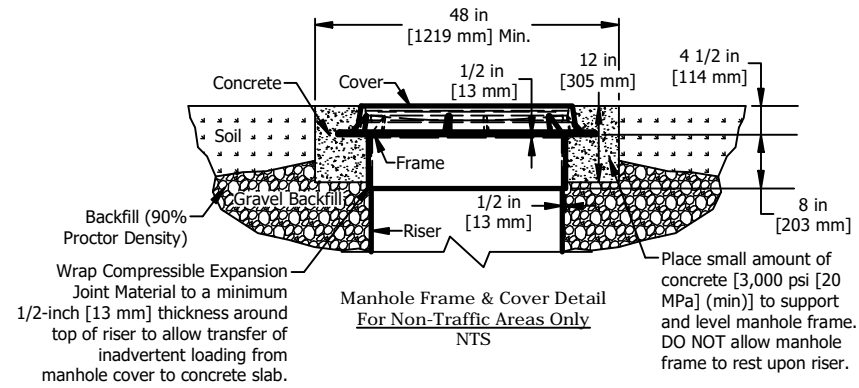

If traffic loading (HS-25) is required or anticipated, a 4-foot [1.22 m] diameter, 14-inch [356 mm] thick reinforced concrete pad must be placed over the Stormwater Treatment System Riser to support and level the manhole frame, as shown. The top of riser pipe must be wrapped with compressible expansion joint material to a minimum 1/2-inch [13 mm] thickness to allow transfer of wheel loads from manhole cover to concrete slab. Manhole cover shall bear on concrete slab and not on riser pipe. The concrete slab shall have a minimum strength of 3,000 psi [20 MPa] and be reinforced with #4 [13 mm] reinforcing steel as shown. Minimum cover over reinforcing steel shall be 1-inch [25 mm]. Top of manhole cover and concrete slab shall be level with finish grade.

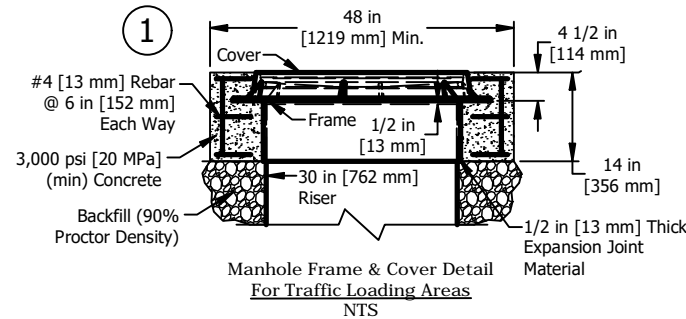

Please see accompanied Aqua-Swirl® specification notes. See Site Plan for actual system orientation. Approximate dry (pick) weight: 8200 lbs [3700 kg].

- ① As an alternative, 42 in [1067 mm] diameter, HS-20/25 rated precast concrete rings may be substituted. 14 in [356 mm] thickness must be maintained.
- ② AS-10s BYP inlet/outlet pipe size ranges from 24 in [610 mm] to 60 in [1524 mm].
- ③ AS-10s chamber height may vary from 104 in [2642 mm] to 140 in [3556 mm], depending on inlet/outlet pipe size.
- ④ Orientation may vary from a minimum of 90° to a maximum of 180°.

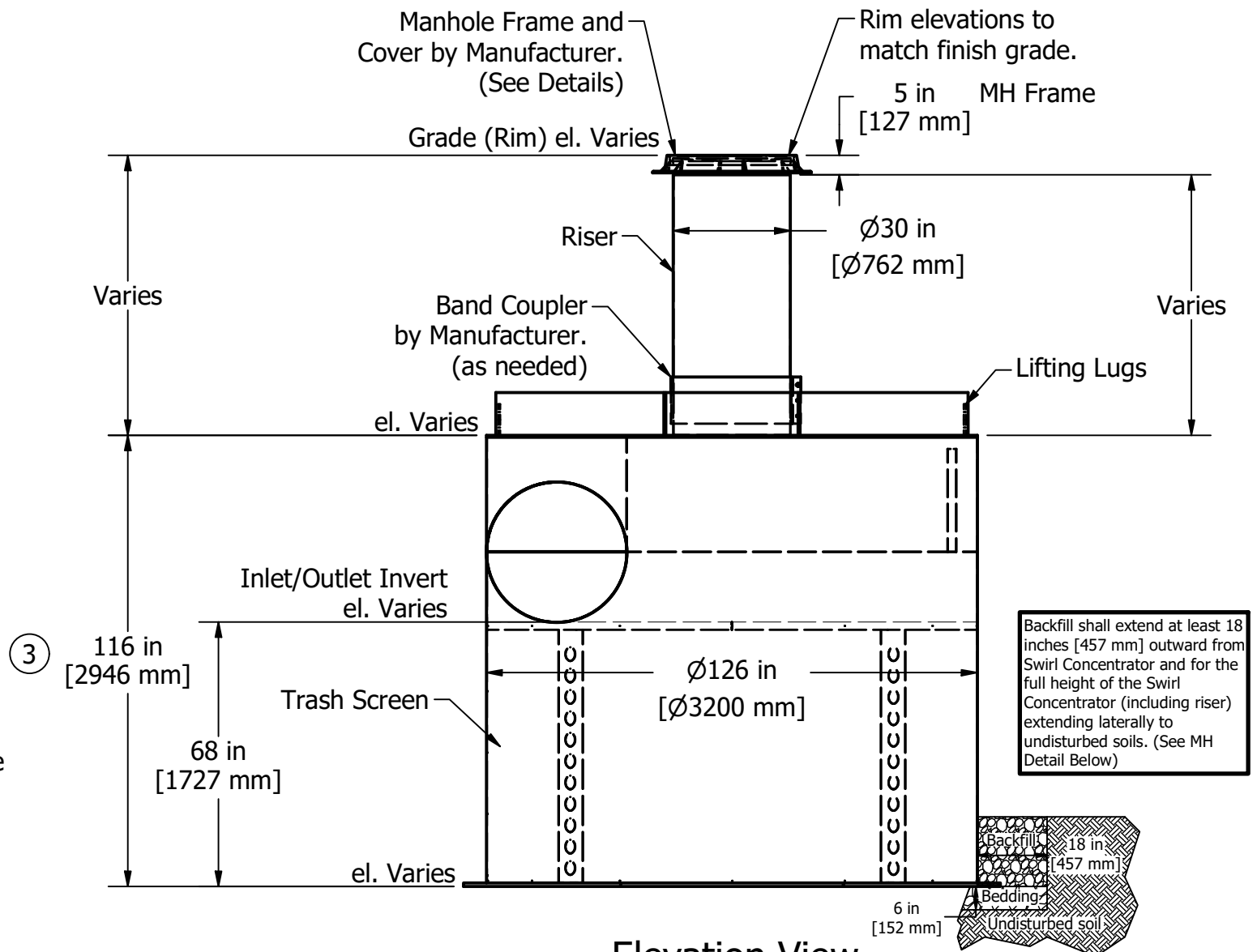
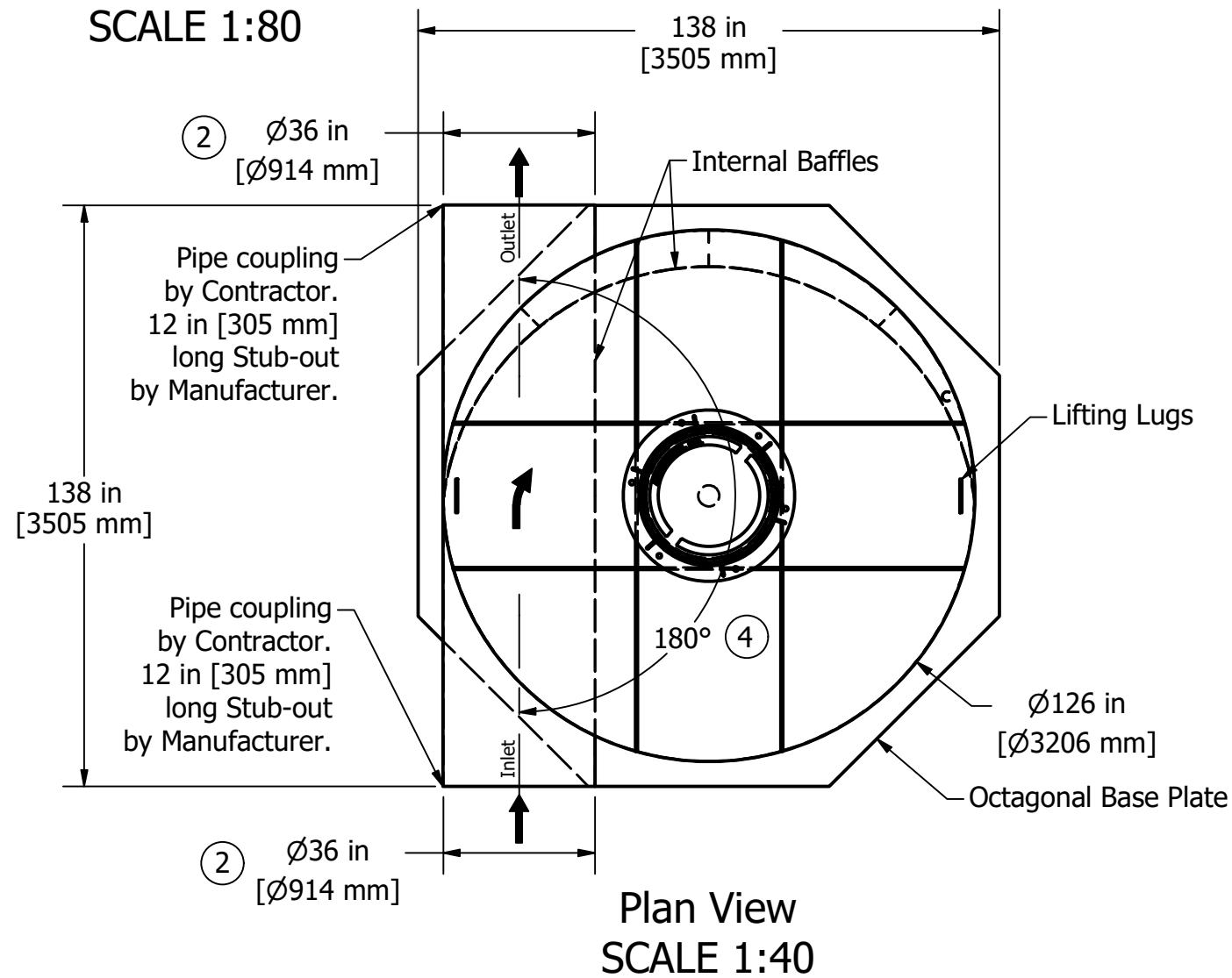

Backfill shall extend at least 18 inches [457 mm] outward from Swirl Concentrator and for the full height of the Swirl Concentrator (including riser) extending laterally to undisturbed soils. (See MH Detail Below)

**Aqua-Swirl® Polymer Coated Steel (PCS)  
Stormwater Treatment System**

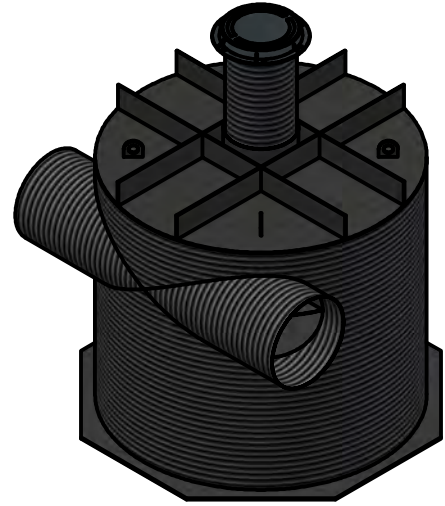

**Projected View  
SCALE 1:80**

Unless other traffic barriers are present, bollards shall be placed around access riser(s) in non-traffic areas to prevent inadvertent loading by maintenance vehicles.

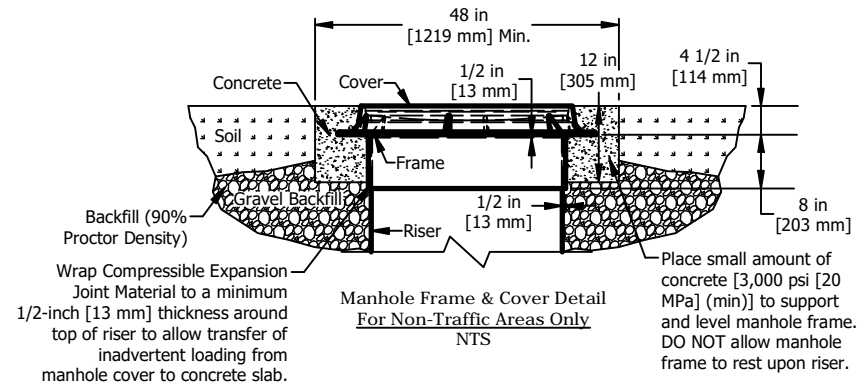

If traffic loading (HS-25) is required or anticipated, a 4-foot [1.22 m] diameter, 14-inch [356 mm] thick reinforced concrete pad must be placed over the Stormwater Treatment System Riser to support and level the manhole frame, as shown. The top of riser pipe must be wrapped with compressible expansion joint material to a minimum 1/2-inch [13 mm] thickness to allow transfer of wheel loads from manhole cover to concrete slab. Manhole cover shall bear on concrete slab and not on riser pipe. The concrete slab shall have a minimum strength of 3,000 psi [20 MPa] and be reinforced with #4 [13 mm] reinforcing steel as shown. Minimum cover over reinforcing steel shall be 1-inch [25 mm]. Top of manhole cover and concrete slab shall be level with finish grade.

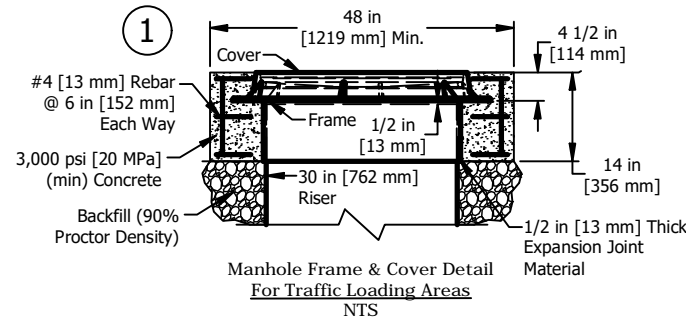

Please see accompanied Aqua-Swirl® specification notes. See Site Plan for actual system orientation. Approximate dry (pick) weight: 11500 lbs [5200 kg].

- ① As an alternative, 42 in [1067 mm] diameter, HS-20/25 rated precast concrete rings may be substituted. 14 in [356 mm] thickness must be maintained.
- ② AS-11s BYP inlet/outlet pipe size ranges from 24 in [610 mm] to 60 in [1524 mm]. (see representative for larger pipe diameters available).
- ③ AS-11s chamber height may vary from 104 in [2642 mm] to 140 in [3556 mm], depending on inlet/outlet pipe size.
- ④ Orientation may vary from a minimum of 90° to a maximum of 180°.

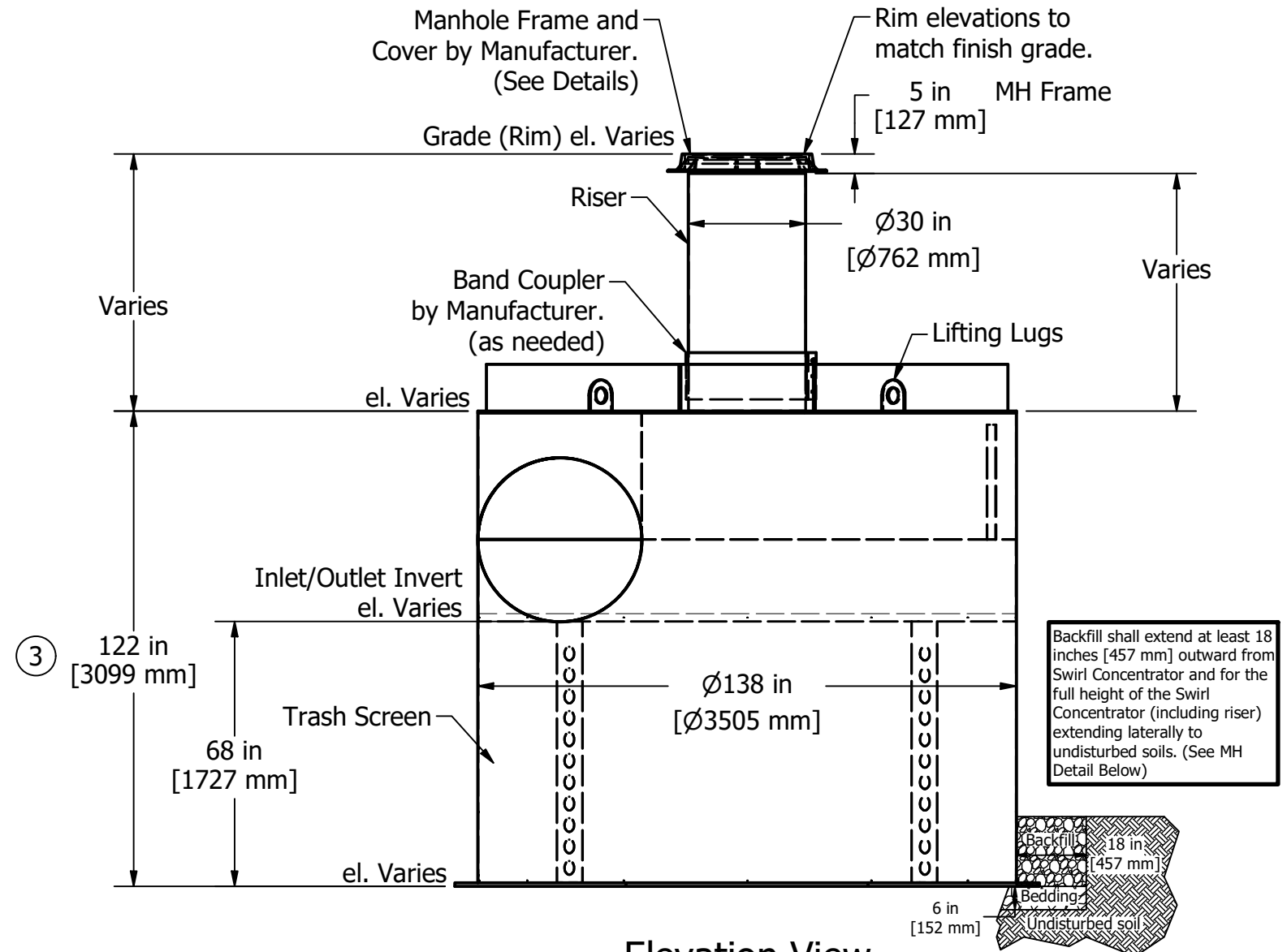
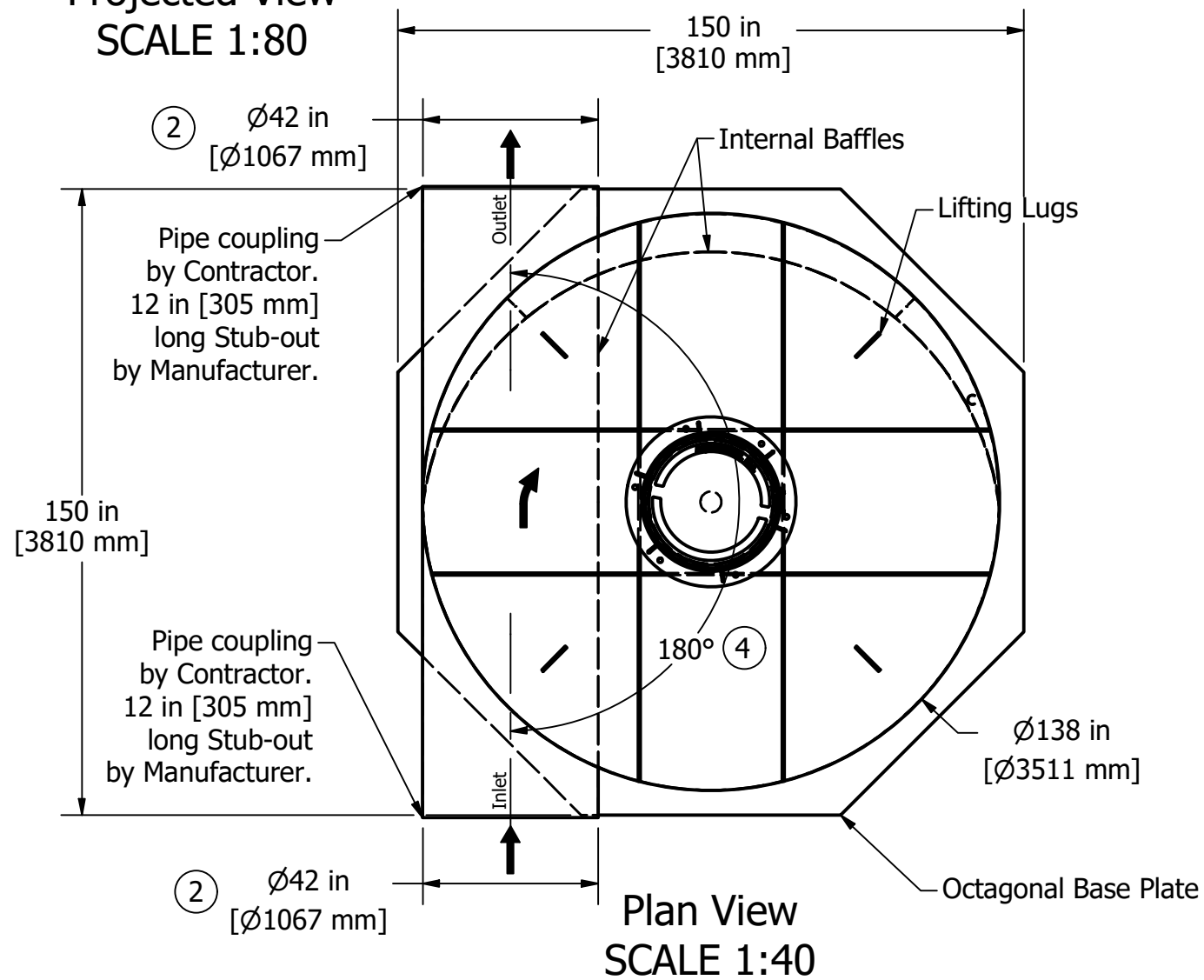



**Aqua-Swirl® Polymer Coated Steel (PCS)  
Stormwater Treatment System**

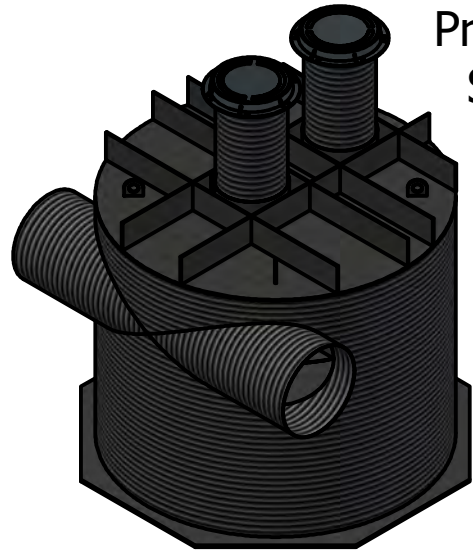

**Projected View  
SCALE 1:80**

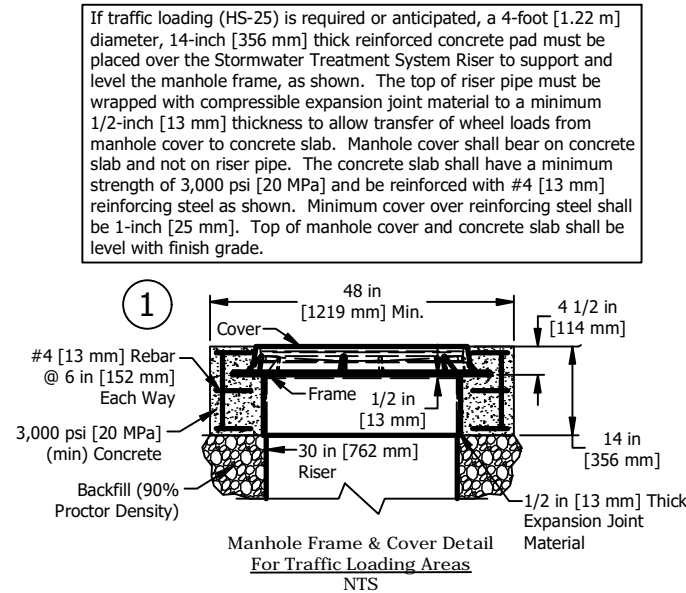
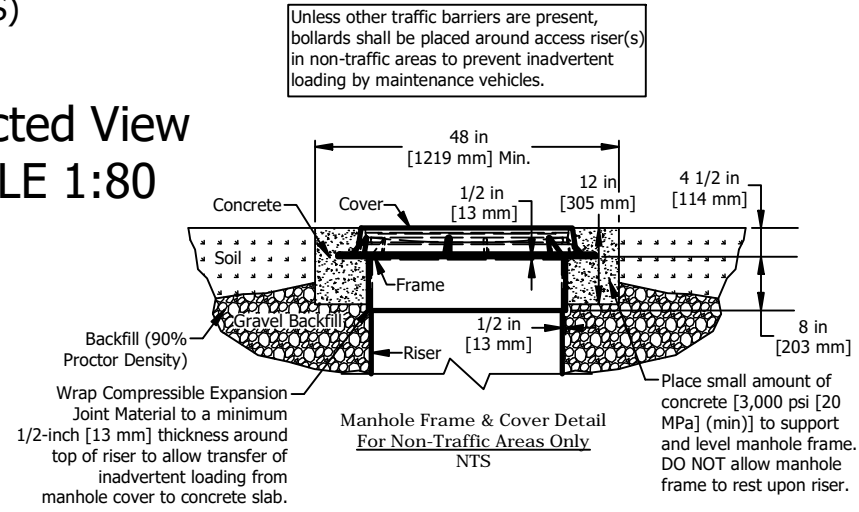

Please see accompanied Aqua-Swirl® specification notes. See Site Plan for actual system orientation. Approximate dry (pick) weight: 12400 lbs [5600 kg].

- ① As an alternative, 42 in [1067 mm] diameter, HS-20/25 rated precast concrete rings may be substituted. 14 in [356 mm] thickness must be maintained.
- ② AS-12s BYP inlet/outlet pipe size ranges from 24 in [610 mm] to 60 in [1524 mm].
- ③ AS-12s chamber height may vary from 104 in [2642 mm] to 140 in [3556 mm], depending on inlet/outlet pipe size.
- ④ Orientation may vary from a minimum of 90° to a maximum of 180°.

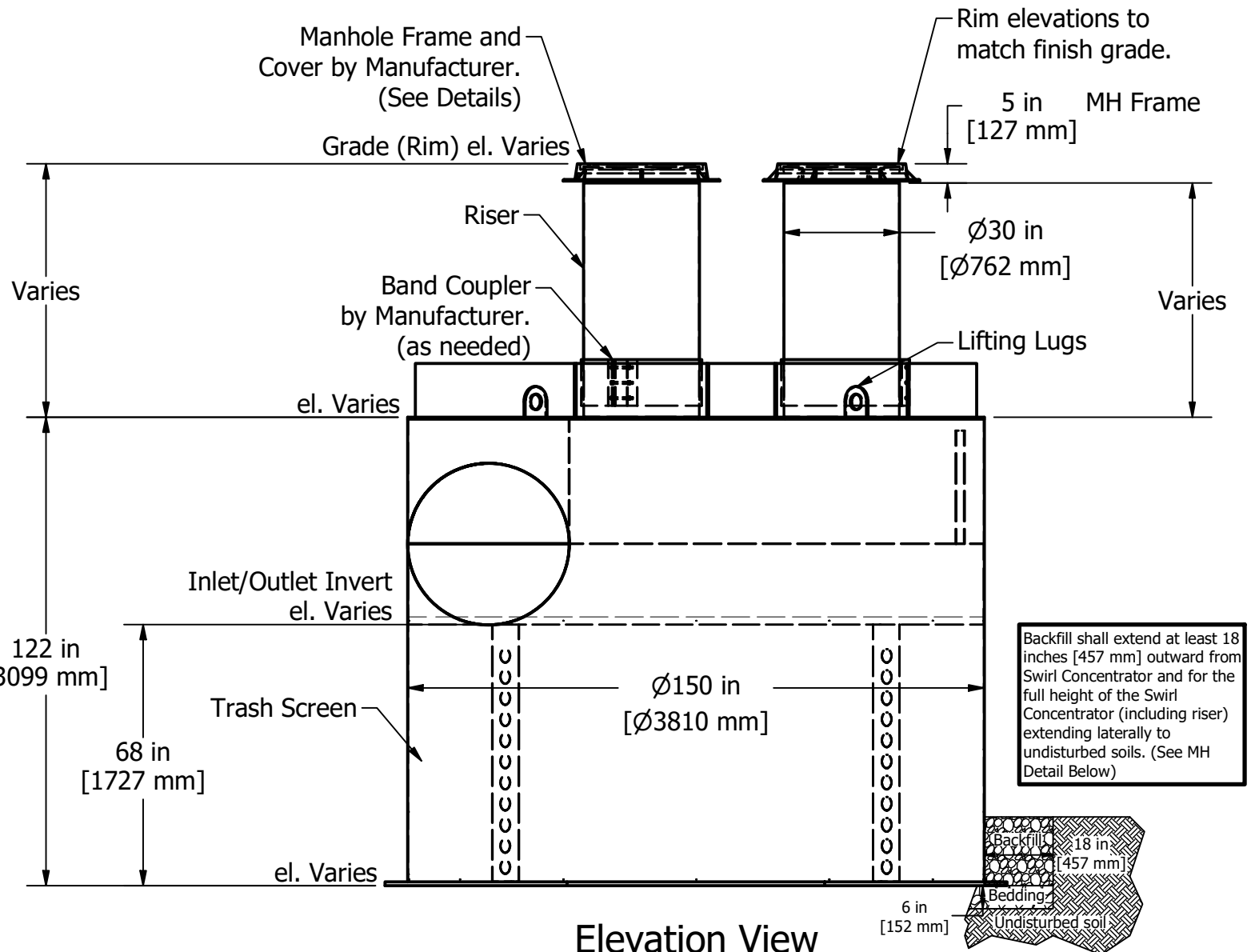
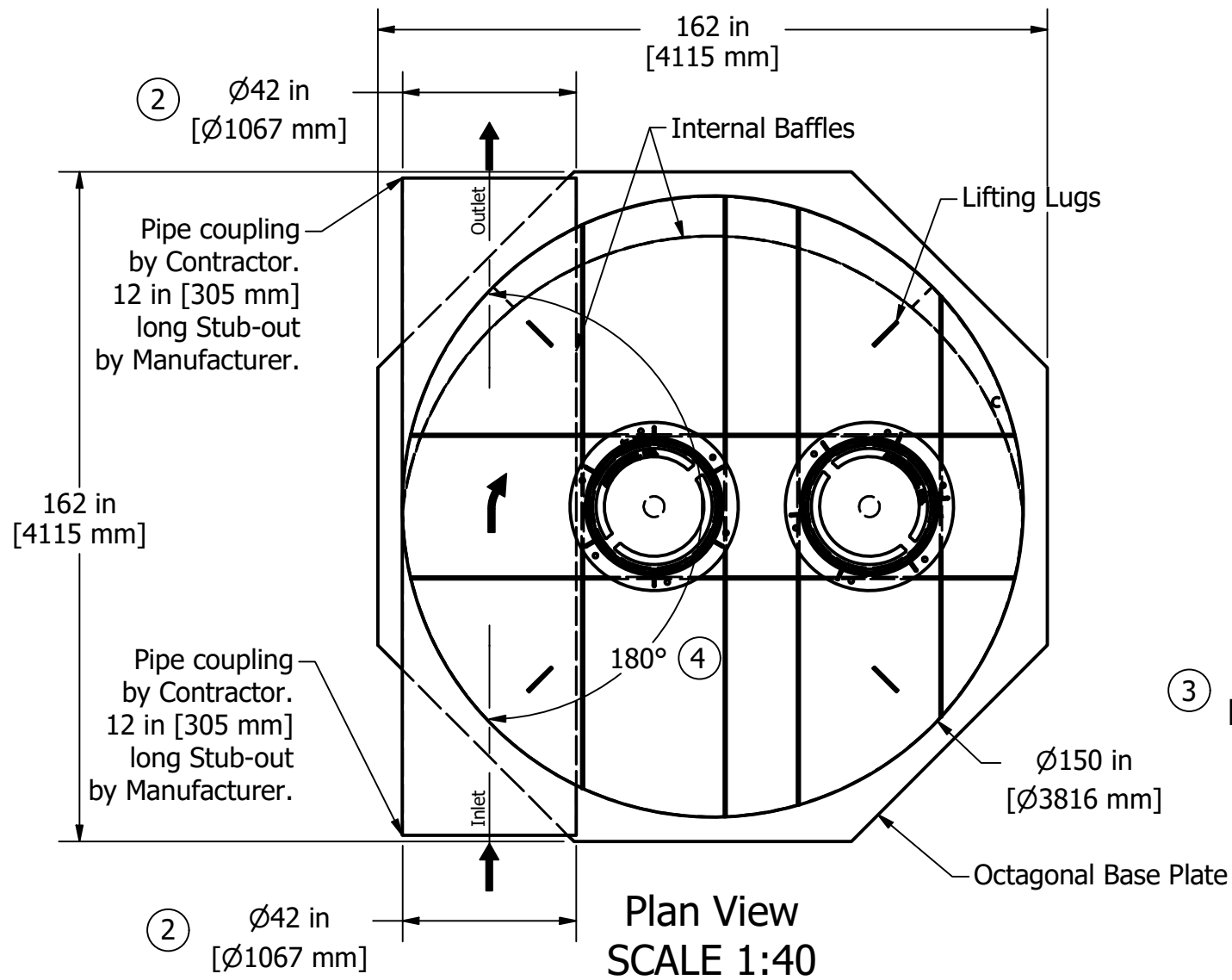

**Aqua-Swirl® Polymer Coated Steel (PCS)  
Stormwater Treatment System**

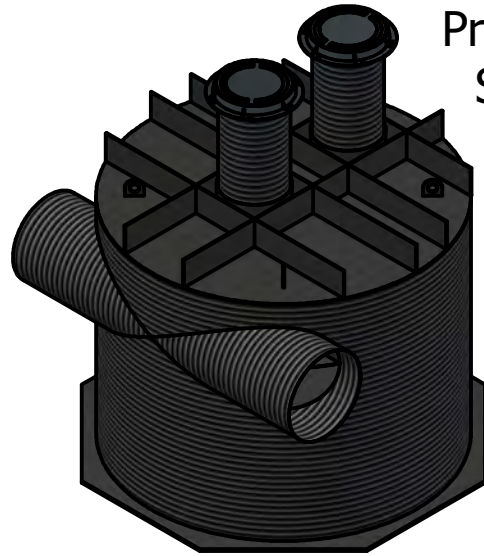

**Projected View  
SCALE 1:80**

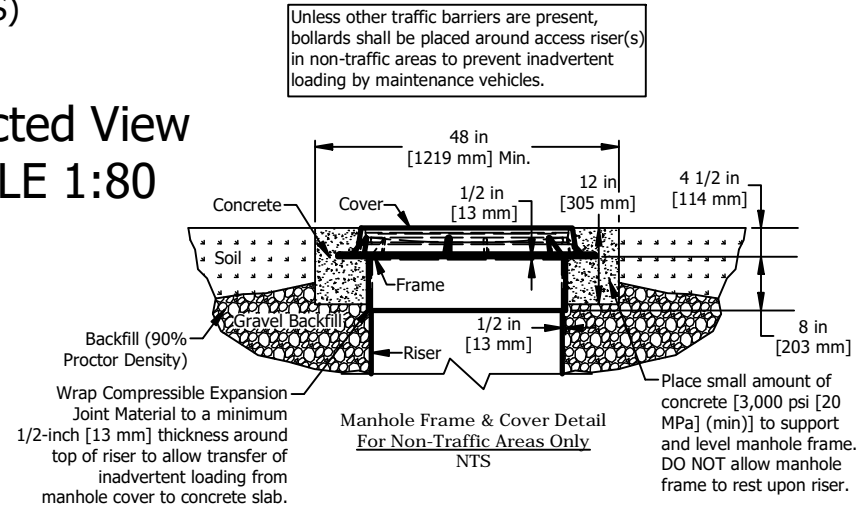

If traffic loading (HS-25) is required or anticipated, a 4-foot [1.22 m] diameter, 14-inch [356 mm] thick reinforced concrete pad must be placed over the Stormwater Treatment System Riser to support and level the manhole frame, as shown. The top of riser pipe must be wrapped with compressible expansion joint material to a minimum 1/2-inch [13 mm] thickness to allow transfer of wheel loads from manhole cover to concrete slab. Manhole cover shall bear on concrete slab and not on riser pipe. The concrete slab shall have a minimum strength of 3,000 psi [20 MPa] and be reinforced with #4 [13 mm] reinforcing steel as shown. Minimum cover over reinforcing steel shall be 1-inch [25 mm]. Top of manhole cover and concrete slab shall be level with finish grade.

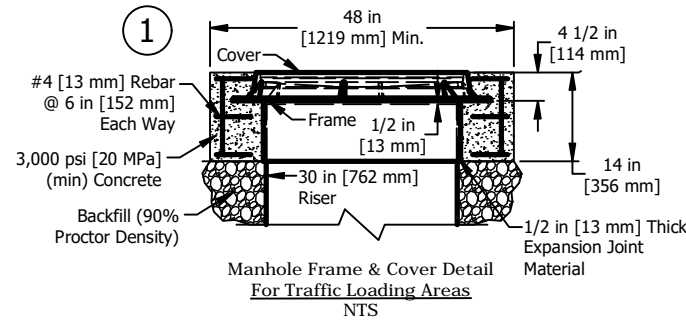

Please see accompanied Aqua-Swirl® specification notes. See Site Plan for actual system orientation. Approximate dry (pick) weight: 14000 lbs [6400 kg].

- ① As an alternative, 42 in [1067 mm] diameter, HS-20/25 rated precast concrete rings may be substituted. 14 in [356 mm] thickness must be maintained.
- ② AS-13s BYP inlet/outlet pipe size ranges from 27 in [686 mm] to 60 in [1524 mm].
- ③ AS-13s chamber height may vary from 107 in [2718 mm] to 140 in [3556 mm], depending on inlet/outlet pipe size.
- ④ Orientation may vary from a minimum of 90° to a maximum of 180°.

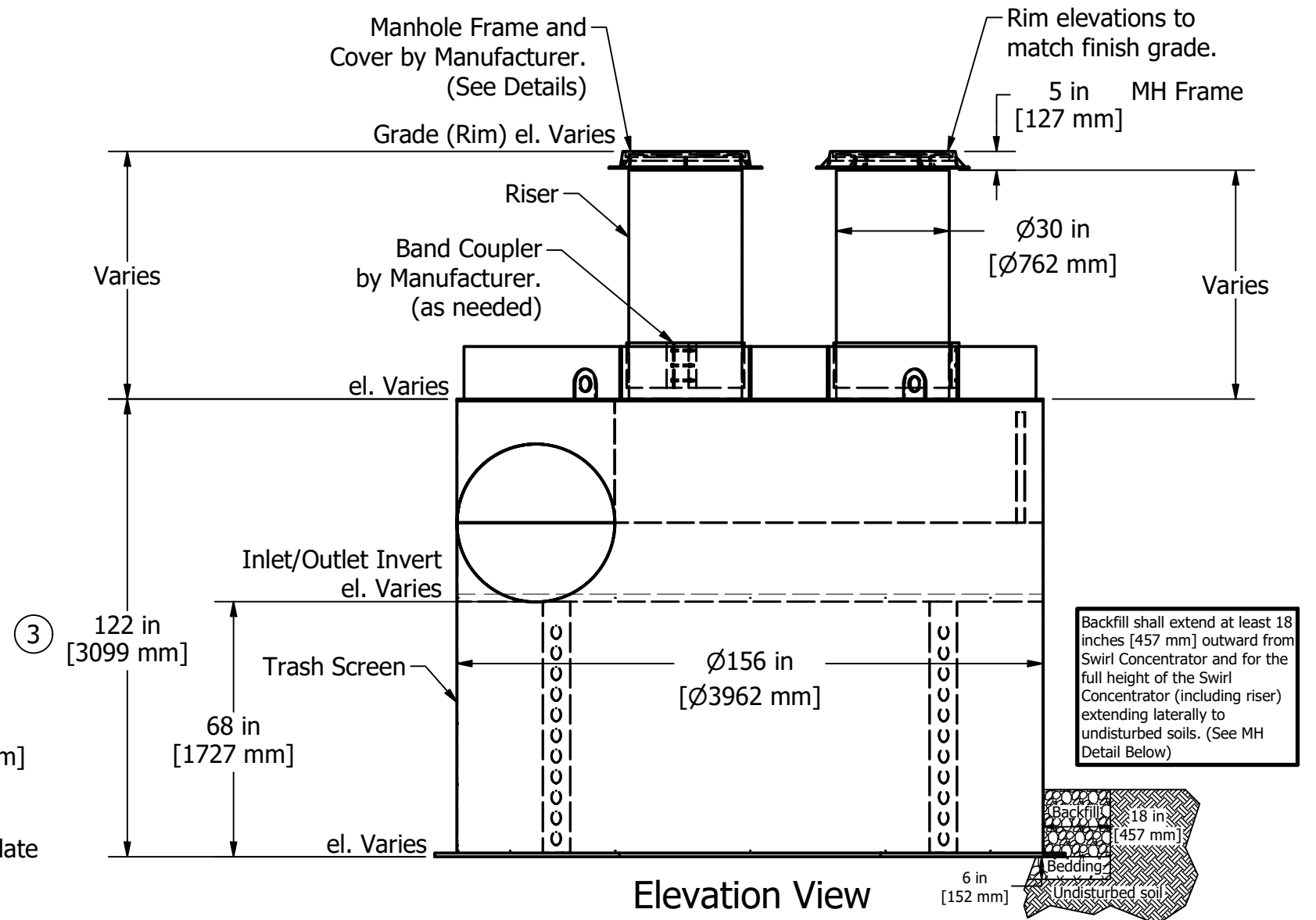
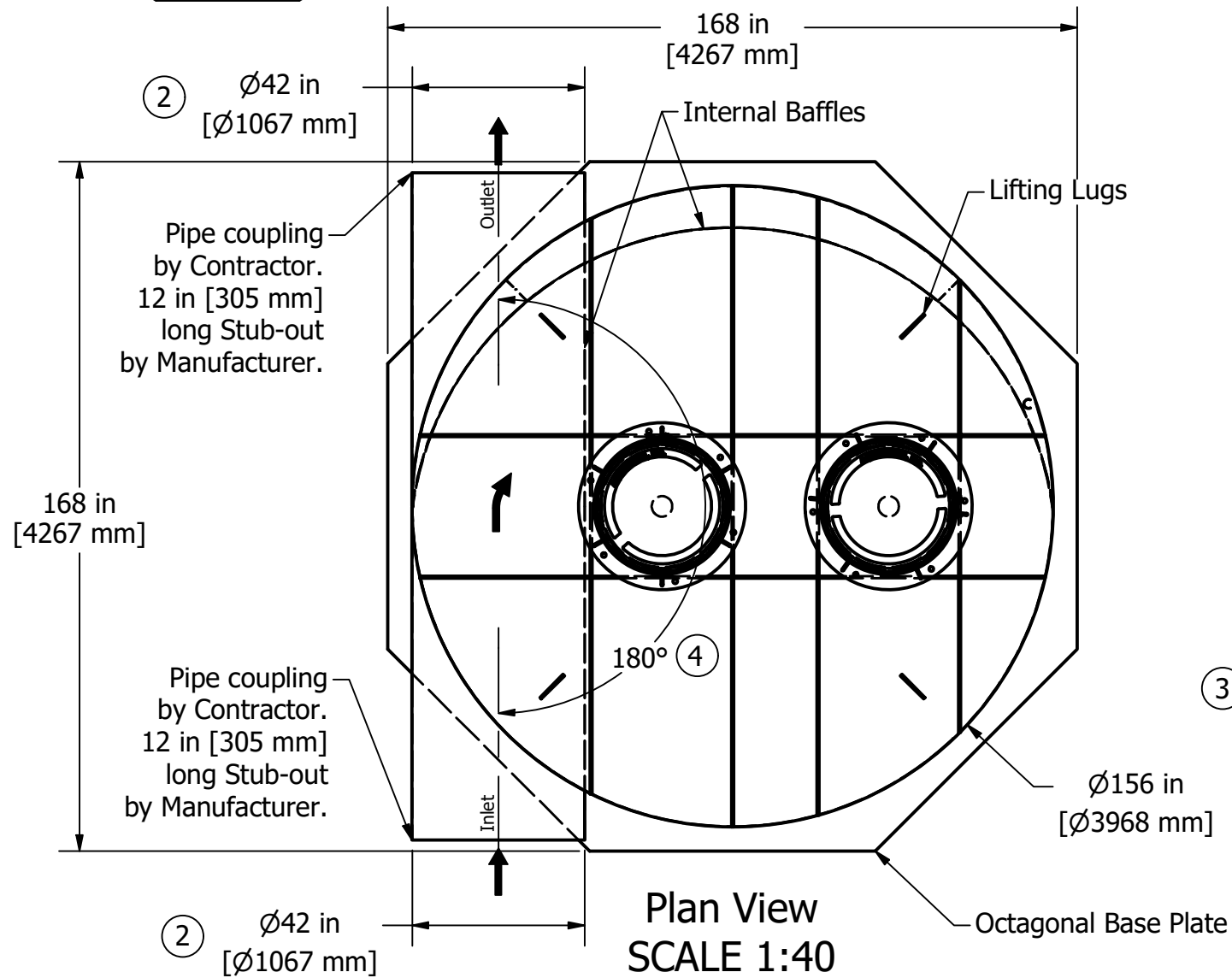

## **APPENDIX B**





Installation of Aqua-Swirl® Trash Capture Model AS-8s, Lodi, CA.



Installation of Aqua-Swirl® Trash Capture Model AS-11s, Lodi, CA.





Installation of Aqua-Swirl® Trash Capture Model AS-10s, Lodi, CA.



Installation of Aqua-Swirl® Trash Capture Model AS-12s, Redondo Beach, CA.



## APPENDIX C



## **Aqua-Swirl™ Specifications**

---

### **GENERAL**

This specification shall govern the performance, materials, and fabrication of the Stormwater Treatment System.

### **SCOPE OF WORK**

The Aqua-Swirl® shall be provided by AquaShield™, Inc., 2733 Kanasita Drive, Suite 111, Chattanooga, TN (888-344-9044), and shall adhere to the following material and performance specifications at the specified design flows and storage capacities.

### **MATERIALS**

A. Stormwater Treatment System shall be made from Polymer Coated Steel (PCS) corrugated pipe meeting the following requirements:

- 1) Steel shall be zinc-coated (galvanized) and conform to ASTM A929 with a coating weight of 2 oz/ft<sup>2</sup> of surface (total both sides) to provide zinc coating thickness of 43µm (0.0017 in.) on each surface. Corrugations shall conform to the requirements stated in Specification A929/A 929M.
- 2) The polymer coating shall conform to ASTM A742. Polymer coating shall be a film coating comprised of at least 85% ethylene acrylic acid copolymer and be capable of being applied to the galvanized steel sheet. After application, the polymer coating shall be free of holes, tears, and discontinuities, and shall be sufficiently flexible so that it will withstand corrugating, forming, lockseaming operations, and punching of holes.
- 3) REQUIREMENTS FOR POLYMER COATING
  - a) Adhesion – There shall be no spalling or cracking of the coating or disbanding of the coating at the cut, when

tested in accordance with ASTM A742/A 742M-03 Section 9.1.

- b) Impact – There shall be no break in the polymer coating when tested in accordance with ASTM A742/A 742M-03 Section 9.2.
- c) Thickness of Coating – The thickness of the polymer coating shall meet the requirements of ASTM A742/A 742M-03 Section 4 when tested in accordance with Section 9.3. The thicknesses indicated are minimum values at any point not less than 3/8 in. (10mm) from an edge.
- d) Holidays – The polymer coating on the steel shall be substantially free of holidays when tested in accordance with ASTM A742/A 742M-03 Section 9.4. An average of two holidays per square foot (22 holidays per square meter) of actual surface area on the test specimen shall be permitted.
- e) Abrasion Resistance – The average abrasion coefficient when tested in accordance with ASTM A742/A 742M-03 Section 9.5, shall be a minimum of 100 (expressed in g/mil of thickness) or 3.9 (expressed in g/μm of thickness).
- f) Imperviousness – There shall be no loosening or separation of the polymer coating from the galvanized steel substrate when tested in accordance with ASTM A742/A 742M-03 Section 9.6.
- g) Freeze-Thaw Resistance – The specimen shall withstand 100 freeze-thaw cycles, per ASTM A742/A 742M-03 Section 9.7, without spalling, disbanding, or other detrimental effects.
- h) Weatherability – The specimens shall withstand 100 hours of weathering with no observable delamination or cracking, when tested in accordance with ASTM A742/A 742M-03 Section 9.8.
- i) Resistance to Microbial Attack – There shall be no effect of microbial attack of the polymer coating when tested in accordance with ASTM A742A 742M-03 Section 9.9.

- B. REJECTION – The Stormwater Treatment System may be rejected for failure to meet any of the requirements of this specification.

**PERFORMANCE**

- A. The Stormwater Treatment System shall include a \_\_\_-inch inner diameter (ID) circular hydrodynamic flow-through treatment chamber to treat the incoming water. A tangential inlet shall be provided to induce a swirling flow pattern that will cause sedimentary solids to accumulate in the bottom center of the chamber in such a way as to prevent re-suspension of captured particles. An arched baffle wall shall be provided in such a way as to prevent floatable liquid oils and solids from exiting the treatment chamber while enhancing the swirling action of the stormwater.
- B. The Stormwater Treatment System shall have a sediment storage capacity of \_\_\_ cubic feet and be capable of capturing \_\_\_ gallons of petroleum hydrocarbons. The Stormwater Treatment System shall have a treatment capacity of \_\_\_\_\_ cubic feet per second (cfs). The Stormwater Treatment System shall be capable of removing floating trash and debris, floatable oils, and 80% of total suspended solids from stormwater entering the treatment chamber.
- C. Service access to the Stormwater Treatment System shall be provided via 30-inch inner diameter (ID) access riser(s) over the treatment chamber such that no confined space entry is required to perform routine inspection and maintenance functions.

**TREATMENT CHAMBER CONSTRUCTION**

- A. The treatment chamber shall be constructed from Polymer Coated Steel (PCS), 16 gauge thickness, with 2.67" x 1/2" corrugation. For sized above 84" ID, the treatment chamber shall be constructed from PCS, 14 gauge thickness, with 2.67" x 1/2" corrugation. For sizes above 120" ID the treatment chamber shall be constructed from PCS, 10 gauge thickness, with 3.00" x 1" corrugation.
- B. Top and bottom plate thickness and reinforcement shall be suitable to withstand H-25 surface loading up to 8 feet of cover depth. Calculations must be provided to justify the thickness of the top

and bottom plates and associated reinforcement. Top and bottom plates shall be Metal Inert Gas (MIG) welded to the treatment chamber structure. All welds shall be free of porosity, pinholes, and obvious defects. Welded areas shall be thoroughly cleaned and coated with two coats of TPC-515-7 black synthetic coating.

- C. The inlets and outlets shall be MIG welded to the treatment chamber structure. All welds shall be free of pinholes, porosity and obvious defects. Welded areas shall be thoroughly cleaned and coated with two coats of TPC-515-7 black synthetic coating.
- D. The arched baffle wall shall be fabricated from PCS and shall be MIG welded to the inside of the treatment chamber with connections made at 180 degrees of each end. Welds shall be coated with two coats of TPC-515-7 black synthetic coating.
- E. Lifting supports may be provided on the exterior of the Stormwater Treatment System in such a way as to allow the prevention of undue stress to critical components of the Stormwater Treatment System during loading, off-loading, and moving operations. The lifting supports shall be constructed as an integral part of the treatment chamber.
- F. A concrete pad shall be required to support the manhole frame and cover. When used in a traffic area the pad design shall be approved by a professional engineer and the calculations must be included in the submittal.
- G. The manufacturer, upon request, can supply anti-floatation/buoyancy calculations. In addition, typical drawings of the AquaShield™ Stormwater Treatment System with concrete anti-floatation structures can also be provided. Anti-floatation structure design and approval are ultimately the responsibility of the specifying engineer. The contractor shall provide the anti-floatation structures.

## **INSTALLATION**

### **A. Excavation and Bedding**

The trench and trench bottom shall be constructed in accordance with ASTM A 798 Section 5, Trench Excavation, Section 6, Foundation, and Section 7, Bedding. The PCS Swirl Concentrator shall be installed on a stable base consisting of at least 6-inches of fine, readily compacted soil or granular fill material, and compacted to 95% proctor density. Bedding shall not contain stones retained on a 3-inch ring, frozen lumps, highly plastic clay, organic material, corrosive material, or other deleterious foreign materials. All required safety precautions for Swirl Concentrator installation are the responsibility of the contractor and shall be per OSHA approved methods.

### **B. Contractor**

The contractor shall be responsible for preparing the site for the system installation including, but not limited to, temporary shoring, excavation, cutting and removing pipe, new pipe, bedding, and compaction. The contractor shall be responsible for furnishing the means to lift the system components off the delivery trucks. The contractor shall be responsible for providing any concrete anti-floatation/anti-creep restraints, anchors, collars, etc. with any straps or connection devices required. The contractor shall be responsible for sealing the pipe connections to the Stormwater Treatment System, backfilling and furnishing all labor, tools, and materials needed.

## **SUBMITTALS**

The contractor shall be provided with dimensional drawings; and when specified, utilize these drawings as the basis for preparation of shop drawings showing details for construction and reinforcing. Shop drawings shall be annotated to indicate all materials to be used and all applicable standards for materials, required tests of materials, and design assumptions for structural analysis. Shop drawings shall be prepared at a scale of not less than ¼ inch per foot. One (1) hard copy of said shop drawings shall be submitted to the specifying engineer for review and approval.

## **QUALITY CONTROL INSPECTION**

### **A. Materials**

The quality of materials, the process of manufacturing, and the finished sections shall be subject to inspection by the specifying engineer. Such inspection may be made at the place of construction, on the work site after delivery, or at both places. The sections shall be subject to rejection at any time if material conditions fail to meet any of the specification requirements, even though sample sections may have been accepted as satisfactory at the place of manufacture. Sections rejected after delivery to the site shall be marked for identification and shall be removed from the site at once. All sections, which are damaged beyond repair after delivery will be rejected; and, if already installed, shall be repaired to the specifying engineer's acceptance level, if permitted, or removed and replaced entirely at the contractor's expense.

### **B. Inspection**

All sections shall be inspected for general appearance, dimensions, soundness, etc.

### **C. Defects**

Structural defects may be repaired (subject to the acceptance of the specifying engineer) after demonstration by the manufacturer that strong and permanent repairs will be made. The specifying engineer, before final acceptance of the components, shall carefully inspect repairs.

## APPENDIX D





**Aqua-Swirl<sup>®</sup>**  
**Stormwater Treatment System**  
**Inspection and Maintenance Manual**



**AquaShield<sup>™</sup>, Inc.**  
**2733 Kanasita Drive**  
**Suite 111**  
**Chattanooga, TN 37343**  
**Toll free (888) 344-9044**  
**Phone: (423) 870-8888**  
**Fax: (423) 826-2112**  
**Email: [info@aquashieldinc.com](mailto:info@aquashieldinc.com)**  
**[www.aquashieldinc.com](http://www.aquashieldinc.com)**

**November 2016**



## Aqua-Swirl<sup>®</sup> Stormwater Treatment System

The Aqua-Swirl<sup>®</sup> Stormwater Treatment System (Aqua-Swirl<sup>®</sup>) is a vortex-type hydrodynamic separator designed and supplied by AquaShield<sup>™</sup>, Inc. (AquaShield<sup>™</sup>). Aqua-Swirl<sup>®</sup> technology removes pollutants including suspended solids, debris, floatables and free-floating oil from stormwater runoff. Both treatment and storage are accomplished in the single swirl chamber without the use of multiple or hidden, blind access chambers.

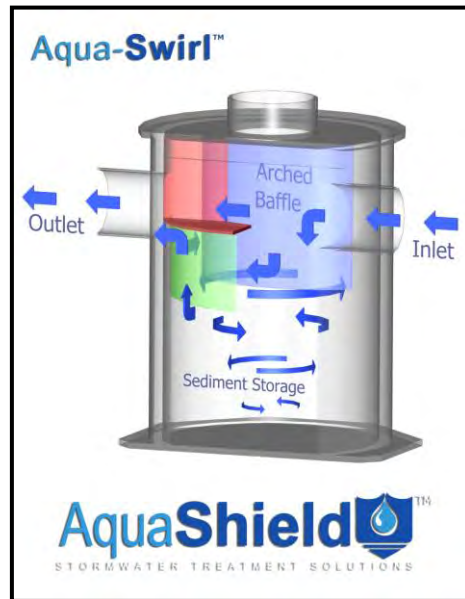

Aqua-Swirl<sup>®</sup> Stormwater Treatment System



Floatable debris in the Aqua-Swirl<sup>®</sup>



## System Operation

---

The treatment operation begins when stormwater enters the Aqua-Swirl<sup>®</sup> through a tangential inlet pipe that produces a circular (or vortex) flow pattern that causes contaminants to settle to the base of the unit. Since stormwater flow is intermittent by nature, the Aqua-Swirl<sup>®</sup> retains water between storm events providing both dynamic and quiescent settling of solids. The dynamic settling occurs during each storm event while the quiescent settling takes place between successive storms. A combination of gravitational and hydrodynamic drag forces encourages the solids to drop out of the flow and migrate to the center of the chamber where velocities are the lowest.

The treated flow then exits the Aqua-Swirl<sup>®</sup> behind the arched outer baffle. The top of the baffle is sealed across the treatment channel, thereby eliminating floatable pollutants from escaping the system. A vent pipe is extended up the riser to expose the backside of the baffle to atmospheric conditions, preventing a siphon from forming at the bottom of the baffle.



## Custom Applications

---

The Aqua-Swirl<sup>®</sup> system can be modified to fit a variety of purposes in the field, and the angles for inlet and outlet lines can be modified to fit most applications. The photo below demonstrates the flexibility of Aqua-Swirl<sup>®</sup> installations using a “twin” configuration in order to double the water quality treatment capacity. Two Aqua-Swirl<sup>®</sup> units were placed side by side in order to treat a high volume of water while occupying a small amount of space.



Custom designed AS-9 Twin Aqua-Swirl<sup>®</sup>



## Retrofit Applications

---

The Aqua-Swirl<sup>®</sup> system is designed so that it can easily be used for retrofit applications. With the invert of the inlet and outlet pipe at the same elevation, the Aqua-Swirl<sup>®</sup> can easily be connected directly to the existing storm conveyance drainage system. Furthermore, because of the lightweight nature and small footprint of the Aqua-Swirl<sup>®</sup>, existing infrastructure utilities (i.e., wires, poles, trees) would be unaffected by installation.



## Aqua-Swirl<sup>®</sup> System Maintenance

The long term performance of any stormwater treatment structure, including manufactured or land based systems, depends on a consistent maintenance plan. Inspection and maintenance functions are simple and easy for the Aqua-Swirl<sup>®</sup> allowing all inspections to be performed from the surface.

It is important that a routine inspection and maintenance program be established for each unit based on: (a) the volume or load of the contaminants of concern, (b) the frequency of releases of contaminants at the facility or location, and (c) the nature of the area being drained.

In order to ensure that our systems are being maintained properly, AquaShield<sup>™</sup> offers a maintenance solution to all of our customers. We will arrange to have maintenance performed.



Aqua-Swirl<sup>®</sup> manhole cover



## Inspection

---

The Aqua-Swirl<sup>®</sup> can be inspected from the surface, eliminating the need to enter the system to determine when cleanout should be performed. In most cases, AquaShield<sup>™</sup> recommends a quarterly inspection for the first year of operation to develop an appropriate schedule of maintenance. Based on experience of the system's first year in operation, we recommend that the inspection schedule be revised to reflect the site-specific conditions encountered. Typically, the inspection schedule for subsequent years is reduced to semi-annual inspection.



## Maintenance

---

The Aqua-Swirl<sup>®</sup> has been designed to minimize and simplify the inspection and maintenance process. The single chamber system can be inspected and maintained entirely from the surface thereby eliminating the need for confined space entry. Furthermore, the entire structure (specifically, the floor) is accessible for visual inspection from the surface. There are no areas of the structure that are blocked from visual inspection or periodic cleaning. Inspection of any free-floating oil and floatable debris can be directly observed and maintained through the manhole access provided directly over the swirl chamber.

### Aqua-Swirl<sup>®</sup> Inspection Procedure

To inspect the Aqua-Swirl<sup>®</sup>, a hook is typically needed to remove the manhole cover. AquaShield<sup>™</sup> provides a customized manhole cover with our distinctive logo to make it easy for maintenance crews to locate the system in the field. We also provide a permanent metal information plate affixed inside the access riser which provides our contact information, the Aqua-Swirl<sup>®</sup> model size, and serial number.

The only tools needed to inspect the Aqua-Swirl<sup>®</sup> system are a flashlight and a measuring device such as a stadia rod or pole. Given the easy and direct accessibility provided, floating oil and debris can be observed directly from the surface. Sediment depths can easily be determined by lowering a measuring device to the top of the sediment pile and to the surface of the water.

It should be noted that in order to avoid underestimating the volume of sediment in the chamber, the measuring device must be carefully lowered to the *top* of the sediment pile. Keep in mind that the finer sediment at the top of the pile may offer less resistance to the measuring device than the larger particles which typically occur deeper within the sediment pile.

The Aqua-Swirl<sup>®</sup> design allows for the sediment to accumulate in a semi-conical fashion as illustrated below. That is, the depth to sediment as measured below the water surface may be less in the center of the swirl chamber; and likewise, may be greater at the edges of the swirl chamber.



Sediment inspection using a stadia rod

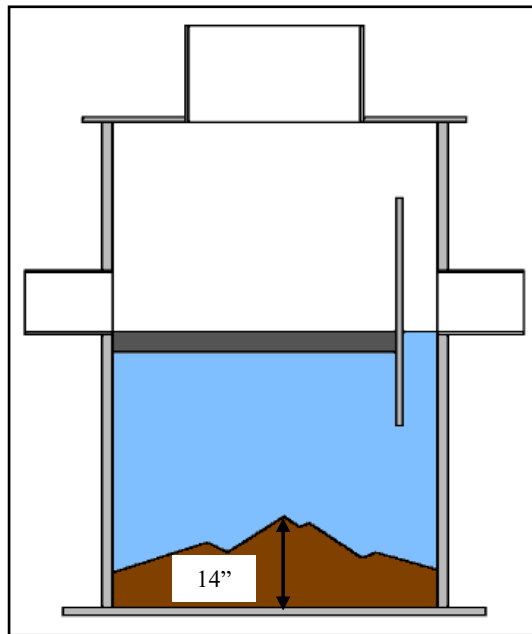

Maximum recommended sediment depth prior to cleanout is 14 inches for all Aqua-Swirl<sup>®</sup> models

### **Aqua-Swirl<sup>®</sup> Cleanout Procedure**

Cleaning the Aqua-Swirl<sup>®</sup> is simple and quick. Free-floating oil and floatable debris can be observed and removed directly through the 30-inch service access riser provided. A vacuum truck is typically used to remove the accumulated sediment and debris. An advantage of the Aqua-Swirl<sup>®</sup> design is that the entire sediment storage area can be reached with a vacuum hose



from the surface reaching all the sides. Since there are no multiple or limited (blind) access chambers in the Aqua-Swirl<sup>®</sup>, there are no restrictions to impede on-site maintenance tasks.

### **Disposal of Recovered Materials**

AquaShield<sup>™</sup> recommends that all maintenance activities be performed in accordance with appropriate health and safety practices for the tasks and equipment being used. AquaShield<sup>™</sup> also recommends that all materials removed from the Aqua-Swirl<sup>®</sup> and any external structures (e.g, bypass features) be handled and disposed in full accordance with any applicable local and state requirements.



Vacuum (vactor) truck quickly cleans the single open access swirl chamber

***Aqua-Swirl<sup>®</sup> Inspection and Maintenance Work Sheets  
on following pages***

# Aqua-Swirl<sup>®</sup> Inspection and Maintenance Manual

## Work Sheets

### SITE and OWNER INFORMATION

Site Name: \_\_\_\_\_

Site Location: \_\_\_\_\_

Date: \_\_\_\_\_ Time: \_\_\_\_\_

Inspector Name: \_\_\_\_\_

Inspector Company: \_\_\_\_\_ Phone #: \_\_\_\_\_

Owner Name: \_\_\_\_\_

Owner Address: \_\_\_\_\_

Owner Phone #: \_\_\_\_\_ Emergency Phone #: \_\_\_\_\_

### INSPECTIONS

#### I. Floatable Debris and Oil

1. Remove manhole lid to expose liquid surface of the Aqua-Swirl<sup>®</sup>.
2. Remove floatable debris with basket or net if any present.
3. If oil is present, measure its depth. Clean liquids from system if one half (1/2) inch or more oil is present.

Note: Water in Aqua-Swirl<sup>®</sup> can appear black and similar to oil due to the dark body of the surrounding structure. Oil may appear darker than water in the system and is usually accompanied by oil stained debris (e.g. Styrofoam, etc.). The depth of oil can be measured with an oil/water interface probe, a stadia rod with water finding paste, a coliwasa, or collect a representative sample with a jar attached to a rod.

#### II. Sediment Accumulation

1. Lower measuring device (e.g. stadia rod) into swirl chamber through service access provided until top of sediment pile is reached.
2. Record distance to top of sediment pile from top of standing water: \_\_\_\_\_ inches.
3. Maximum recommended sediment depth prior to cleanout is 14 inches for all models. Consult system shop drawing for treatment chamber depth as measured from the inlet pipe invert to base of the unit.



### **III. Diversion Structures (External Bypass Features)**

If a diversion (external bypass) configuration is present, it should be inspected as follows:

1. Inspect weir or other bypass feature for structural decay or damage. Weirs are more susceptible to damage than off-set piping and should be checked to confirm that they are not crumbling (concrete or brick) or decaying (steel).
2. Inspect diversion structure and bypass piping for signs of structural damage or blockage from debris or sediment accumulation.
3. When feasible, measure elevations on diversion weir or piping to ensure it is consistent with site plan designs.
4. Inspect downstream (convergence) structure(s) for sign of blockage or structural failure as noted above.

## **CLEANING**

Schedule cleaning with local vacor company or AquaShield™ to remove sediment, oil and other floatable pollutants. The captured material generally does not require special treatment or handling for disposal. Site-specific conditions or the presence of known contaminants may necessitate that appropriate actions be taken to clean and dispose of materials captured and retained by the Aqua-Swirl®. All cleaning activities should be performed in accordance with property health and safety procedures.

AquaShield™ always recommends that all materials removed from the Aqua-Swirl® during the maintenance process be handled and disposed in accordance with local and state environmental or other regulatory requirements.

## **MAINTENANCE SCHEDULE**

### **I. During Construction**

Inspect the Aqua-Swirl® every three (3) months and clean the system as needed. The Aqua-Swirl® should be inspected and cleaned at the end of construction regardless of whether it has reached its maintenance trigger.

### **II. First Year Post-Construction**

Inspect the Aqua-Swirl® every three (3) months and clean the system as needed.

Inspect and clean the system once annually regardless of whether it has reached its sediment or floatable pollutant storage capacity.

### **III. Second and Subsequent Years Post-Construction**

If the Aqua-Swirl® did not reach full sediment or floatable pollutant capacity in the First Year Post-Construction period, the system can be inspected and cleaned once annually.

If the Aqua-Swirl<sup>®</sup> reached full sediment or floatable pollutant capacity in less than 12 months in the First Year Post-Construction period, the system should be inspected once every six (6) months and cleaned as needed. The Aqua-Swirl<sup>®</sup> should be cleaned annually regardless of whether it reaches its sediment or floatable pollutant capacity.

#### IV. Bypass Structures

Bypass structures should be inspected whenever the Aqua-Swirl<sup>®</sup> is inspected. Maintenance should be performed on bypass structures as needed.

### MAINTENANCE COMPANY INFORMATION

Company Name: \_\_\_\_\_

Street Address: \_\_\_\_\_

City: \_\_\_\_\_ State/Prov.: \_\_\_\_\_ Zip/Postal Code: \_\_\_\_\_

Contact: \_\_\_\_\_ Title: \_\_\_\_\_

Office Phone: \_\_\_\_\_ Cell Phone: \_\_\_\_\_

### ACTIVITY LOG

Date of Cleaning: \_\_\_\_\_ (Next inspection should be 3 months from this data for first year).

Time of Cleaning: Start: \_\_\_\_\_ End: \_\_\_\_\_

Date of Next Inspection: \_\_\_\_\_

Floatable debris present:      Yes              No

Notes: \_\_\_\_\_

\_\_\_\_\_

\_\_\_\_\_

Oil present:    Yes              No    Oil depth (inches): \_\_\_\_\_

Measurement method and notes: \_\_\_\_\_

\_\_\_\_\_

\_\_\_\_\_

### STRUCTURAL CONDITIONS and OBSERVATIONS



# Aqua-Swirl®

## TABULAR MAINTENANCE SCHEDULE

Date Construction Started: \_\_\_\_\_

Date Construction Ended: \_\_\_\_\_

### During Construction

Activity	Month											
	1	2	3	4	5	6	7	8	9	10	11	12
Inspect and Clean as needed			X			X			X			X
Inspect Bypass and maintain as needed			X			X			X			X
Clean System*												X*

\* The Aqua-Swirl® should be cleaned **once a year** regardless of whether it has reached full pollutant storage capacity. In addition, the system should be cleaned at the **end of construction** regardless of whether it has reach full pollutant storage capacity.

### First Year Post-Construction

Activity	Month											
	1	2	3	4	5	6	7	8	9	10	11	12
Inspect and Clean as needed			X			X			X			X
Inspect Bypass and maintain as needed			X			X			X			X
Clean System*												X*

\* The Aqua-Swirl® should be cleaned **once a year** regardless of whether it has reached full pollutant storage capacity.

### Second and Subsequent Years Post-Construction

Activity	Month											
	1	2	3	4	5	6	7	8	9	10	11	12
Inspect and Clean as needed												X*
Inspect Bypass, maintain as needed												X*
Clean System*												X*

\* If the Aqua-Swirl® did **not** reach full sediment or floatable pollutant capacity in the First Year Post-Construction period, the system can be inspected and cleaned once annually.

If the Aqua-Swirl® **reached** full sediment or floatable pollutant capacity in less than 12 months in the First Year Post-Construction period, the system should be inspected once every six (6) months or more frequently if past history warrants, and cleaned as needed. The Aqua-Swirl® should be cleaned annually regardless of whether it reaches its full sediment or floatable pollutant capacity.

## APPENDIX E

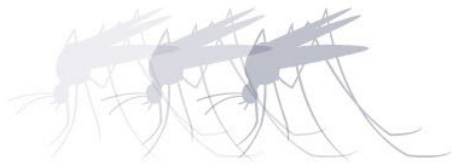

**MVCAC**  
Mosquito and Vector Control Association of California

One Capitol Mall, Suite 320 • Sacramento, CA 95814 • p: (916) 440-0826 • f: (916) 444-7462 • e: [mvcac@mvcac.org](mailto:mvcac@mvcac.org)

AquaShield, Inc.  
9580 Oak Avenue, Suite 7-203  
Folsom, CA 95630

January 6, 2023

Dear Mr. Santos,

Thank you for the submission of the AquaShield Aqua-Swirl full trash capture devices models AS-2s through AS-13s for review by the Mosquito and Vector Control Association of California pursuant to the SWRCB Trash Treatment Control Device Application Requirements. The Association has reviewed the conceptual drawings for the Aqua-Swirl trash capture devices models AS-2s through AS-13s and verifies that provisions have been included in the designs that allow for full visual access to all areas for presence of standing water, and when necessary, allows for treatments of mosquitoes.

While this verification letter confirms that inspection and treatment for the purpose of minimizing mosquito production should be possible with the Aqua-Swirl trash capture devices as presented, it does not affect the local mosquito control agency's rights and remedies under the State Mosquito Abatement and Vector Control District Law. For example, if the installed device or the associated stormwater system infrastructure becomes a mosquito breeding source, it may be determined by a local mosquito control agency to be a public nuisance in accordance with California Health and Safety Code sections 2060-2067.

"Public nuisance" means any of the following:

1. Any property, excluding water that has been artificially altered from its natural condition so that it now supports the development, attraction, or harborage of vectors. The presence of vectors in their developmental stages on a property is prima facie evidence that the property is a public nuisance.
2. Any water that is a breeding place for vectors. The presence of vectors in their developmental stages in the water is prima facie evidence that the water is a public nuisance.
3. Any activity that supports the development, attraction, or harborage of vectors, or that facilitates the introduction or spread of vectors. (Heal. & Saf. Code § 2002 (j).)

Declaration of a facility or property as a public nuisance may result in penalties as provided under the Health and Safety Code. Municipalities and the vendors they work with are encouraged to discuss the design, installation, and maintenance of stormwater trash capture devices with their local mosquito control agency to reduce the potential for disease transmission and public nuisance associated with mosquito production.

Sincerely,

Megan MacNee  
MVCAC Executive Director

## APPENDIX F



## **LIMITED WARRANTY**

**WARRANTY:** AquaShield, Inc., warrants its products against failure due to improper workmanship or defective materials, for a period of twelve (12) months from delivery date; provided, however, that AquaShield, Inc.'s, liability shall be limited to the least of the following: (1) the cost to repair such product; (2) the cost to replace the product; or (3) the purchase price of the product. If the product is replaced, such replacement shall be F.O.B. point of manufacture with freight allowed. In no case shall the cost of dismantling or installation be covered. In no event shall AquaShield, Inc., be liable for any other damages, including, but not limited to, consequential or incidental damages or loss of income. AquaShield, Inc., makes no warranty express or implied as to the merchantability or fitness for any particular purpose of the property sold subject to this Limited Warranty.

Except as expressed in this section, AquaShield, Inc., makes no warranties, express or implied. AquaShield, Inc.'s liability shall be limited to the warranties expressed herein, and AquaShield, Inc., shall not be liable for any direct or consequential damages, including loss of use, which customers may suffer.

This Limited Warranty shall not apply to any products which are abused or misused.

Independent Sales Agent is not and cannot represent itself as an employee of AquaShield, Inc., and shall not make any representations or warranties on behalf of AquaShield, Inc. Independent Sales Agent will not assume or create any obligation on behalf of AquaShield, Inc., other than as evidenced by this Limited Warranty.

This Limited Warranty shall be construed and interpreted in accordance with the laws of the State of Tennessee, and any claim or cause of action relating to any of AquaShield's products or installations shall be brought in a state of federal court in Hamilton County, Tennessee, and the parties agree that the exclusive venue for any such action shall be in said courts.



## **APPENDIX G**



## **Laboratory Testing of the Aqua-Swirl<sup>®</sup> Stormwater Treatment System Model AS-3s for Trash Retention**



*Prepared by:*

AquaShield<sup>TM</sup>, Inc.  
2733 Kanasita Drive, Suite 111  
Chattanooga, Tennessee 37343  
(888) 344-9044  
Fax (423) 826-2112  
[www.aquashieldinc.com](http://www.aquashieldinc.com)

March 28, 2017

**Aqua-Swirl<sup>®</sup> Model AS-3 Trash Retention Testing**

The purpose of this report is to provide documentation of laboratory testing methodologies and results of trash retention testing for the AquaShield™, Inc. (AquaShield™) Aqua-Swirl® Stormwater Treatment System. A full scale, commercially available Aqua-Swirl® Model AS-3s was tested in the presence of an independent observer to assess its capability of retaining gross solids (trash) commonly found in stormwater runoff. Results of this testing program confirm that the Aqua-Swirl® qualifies as a full-capture device under the California Trash TMDL.

## **1.0 TEST UNIT DESCRIPTION**

### **1.1 General Information**

Aqua-Swirl® technology is well known in the stormwater community for its ability to remove suspended sediment. The prestigious New Jersey Corporation for Advanced Technology (NJCAT) has verified Aqua-Swirl® technology in both laboratory and field (TARP Tier II) testing programs. In addition, the Aqua-Swirl® has been issued both Laboratory Certification and Field Test Certification by the New Jersey Department of Environmental Protection (NJDEP).

The Aqua-Swirl® Model AS-3s system relies on a combination of vortex-type hydrodynamic separation processes and an internal screen. A drawing of the AS-3s test unit is shown below in **Figure 1** which includes a depiction of the flow path through the system. This test unit is constructed of polymer coated steel (PCS) that includes a 4.6 square foot trash retention screen to prevent material 5,000 microns (5.0 mm) and greater in size from escaping the device. The top of the AS-3s was open to facilitate testing.

Aqua-Swirl® models are based on vortex-type hydrodynamic separation technology that provides for the removal of suspended sediment, trash (including neutrally buoyant material) and free-floating oil using a single cylindrical chamber for both treatment and storage of captured material. The decreasing flow rate in the swirl chamber causes suspended non-buoyant material to fall out of suspension and settle to the bottom of the chamber. The tested Aqua-Swirl® design incorporated a 4.6 square foot, 4,700 micron (4.7 mm) mesh screen. The trash retention screen is affixed to the base of the arched baffle and extends vertically below the baffle. The base of the screen is capped horizontally and attaches to the wall of the swirl chamber to prevent trash material from escaping behind the baffle. Floatables are captured and retained on the inlet side of the arched baffle. Additional resources for the Aqua-Swirl® are available at <http://www.aquashieldinc.com/-aqua-swirl-resources.html>.

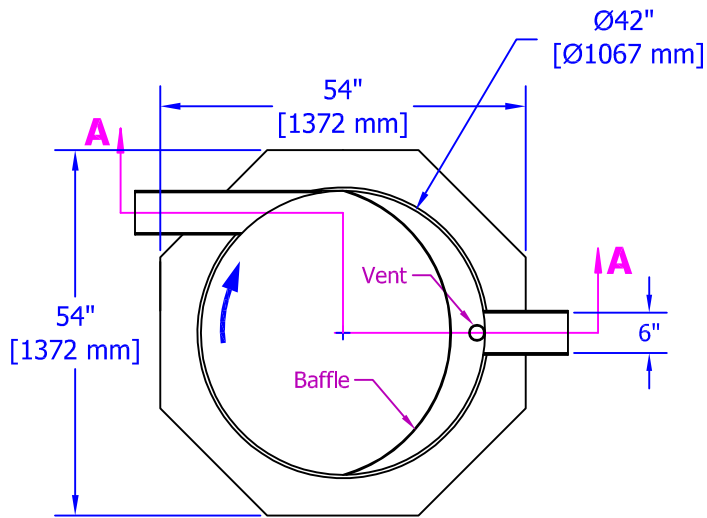

**Plan View**

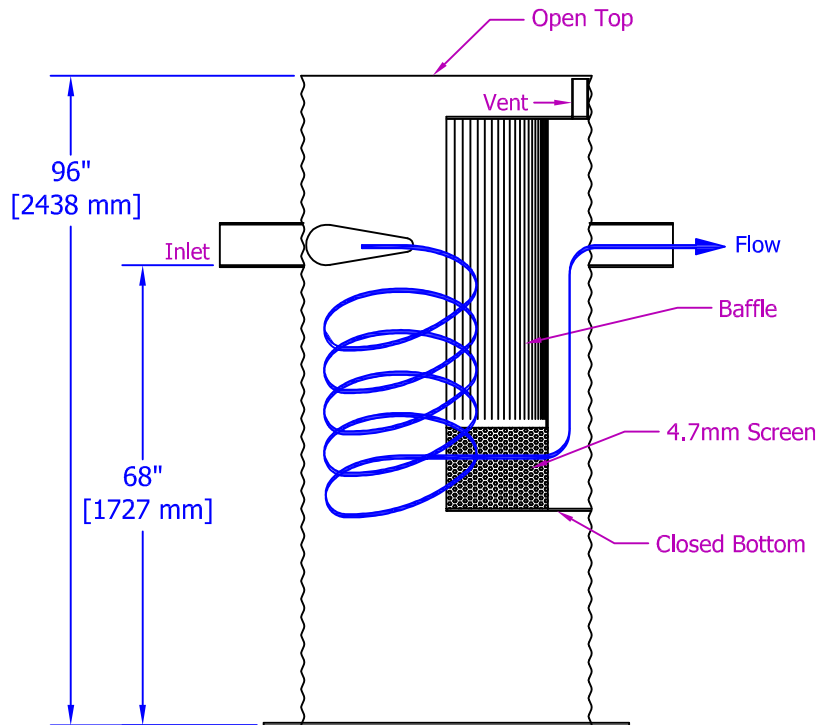

**Section A-A**

Document:	AS-3 SHOP	Rvwed	Rvw. Date	Rev. Date	Description of Revision
Drawn By:	SCE				
Scale:	NTS				
Date:	01/06/16				
U.S. Patent No. 6524473 and other Patent Pending					

## 1.2 Mode of Operation

Operation begins when stormwater enters the Aqua-Swirl<sup>®</sup> through a tangential inlet pipe which produces a circular swirl (or vortex) flow pattern (**Figure 1**). Dynamic settling of material occurs within the swirl chamber during each storm event while quiescent settling takes place between storms. A combination of gravitational and hydrodynamic drag forces encourages the solids to drop out of the flow and migrate to the center of the swirl chamber where velocities are the lowest.

Water exits the Aqua-Swirl<sup>®</sup> by flowing through the trash screen perforations and then upward and behind the arched baffle. All water must flow through the trash screen in order to exit the device. The top of the baffle is sealed across the top of the area behind the baffle (effluent treatment channel). A vent pipe is extended up the riser to expose the back side of the baffle to atmospheric conditions thereby preventing a siphon from forming at the bottom of the baffle.

## 1.3 Inspection and Maintenance

Routine visual inspections are recommended to ensure that an Aqua-Swirl<sup>®</sup> facility provides effective functionality. Cleanout of accumulated material is necessary when trash and oil covers the majority of the water surface area such as that shown below in **Figure 2** taken from an active Aqua-Swirl<sup>®</sup> facility. Captured material contents may vary for each maintenance cycle which can include large polyethylene bottles, styrofoam cups and other large debris as depicted below.



Figure 2. Example of captured trash in an active Aqua-Swirl<sup>®</sup> site.

A vacuum truck is used to remove the accumulated materials through the open access manhole. Larger Aqua-Swirl<sup>®</sup> models utilize two manholes to ensure that the entire treatment and storage areas can be thoroughly cleaned. All maintenance activities can be performed from the surface without entry to the system. AquaShield<sup>™</sup> recommends quarterly inspections and annual cleanout events; however, site conditions will ultimately dictate those event cycles. An Aqua-Swirl<sup>®</sup> Inspection & Maintenance Manual is provided for all site installations. The manual is also available at <http://www.aquashieldinc.com/-aqua-swirl-resources.html>. The manual describes the technology and cleaning methods, and includes log sheets to document facility conditions and operational activities.

## 2.0 TEST LOOP

The test loop is a recirculation system designed to provide metered flow. **Figure 3** is an illustration of the test loop. A 10 hp pump draws tap water from a supply tank whereby influent piping is routed to the AS-3s test unit. Effluent piping from the AS-3s leads back to a separate 2,700 gallon water supply tank.

### 2.1 Flow

Inflow to the AS-3s test unit uses a factory calibrated Badger M-2000 flow meter. A 1-micron filter assembly manufactured by Filtra Systems, Model # FSSB-080808CSVR2, Option B is used to ensure that clean water is entering the test unit. A polyethylene 1 mm mesh opening net was placed over the opening of the effluent pipe where water discharges into the water supply tank (**Figure 4**). The purpose of the net was to catch trash material in the event that such material escaped the test unit.



Figure 4. Net at effluent pipe discharge.



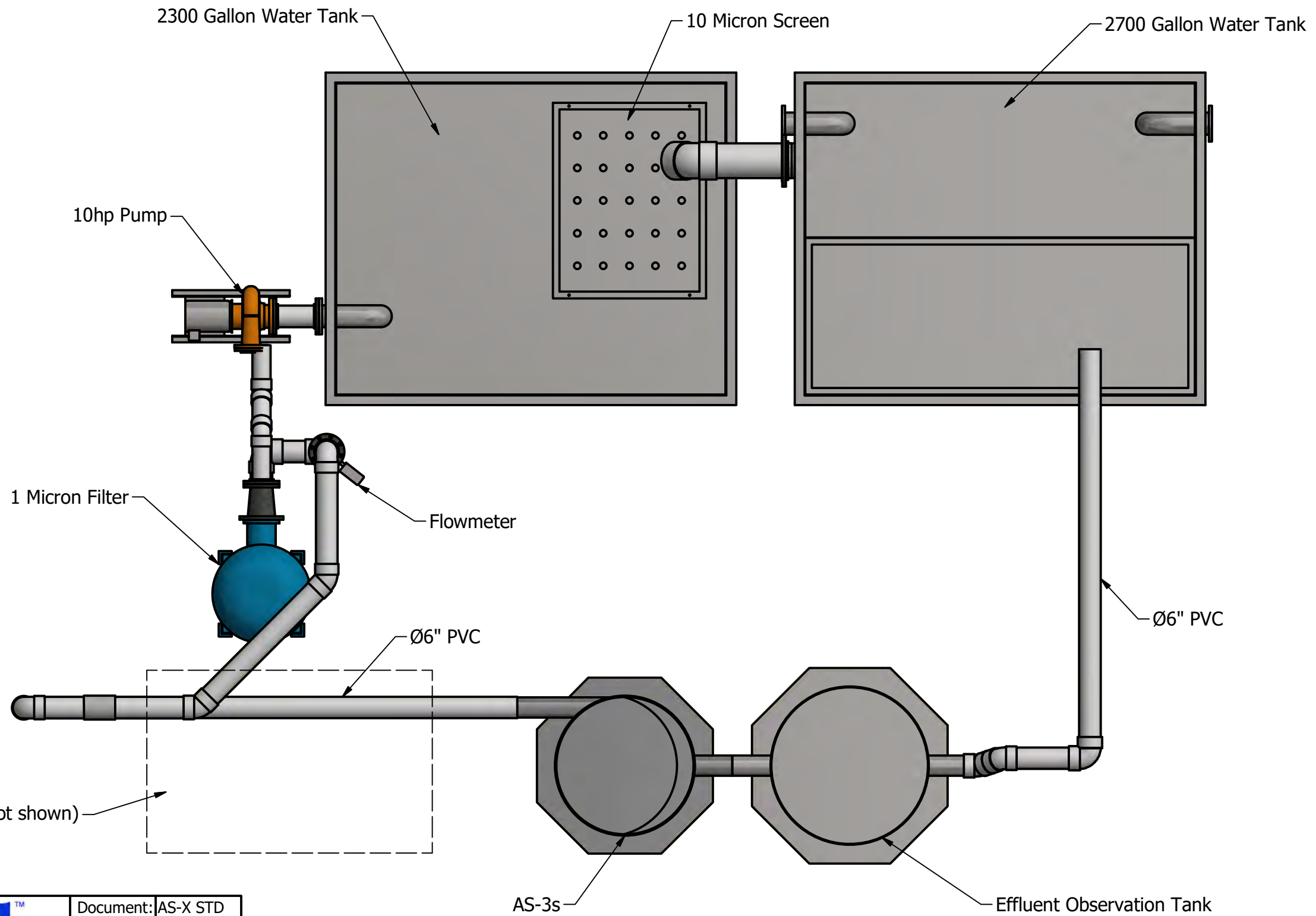

Figure 3

### 3.0 TRASH DESCRIPTION

#### 3.1 Trash Composition

A composition of simulated trash was prepared by AquaShield™ for this testing program. The types of trash material and number of pieces associated with each of the three performance runs are listed below in **Table 1**. Given the absence of a commercially available gross solids test material, a test composition was fundamentally based on a trash specification cited in the report titled “*Laboratory Testing of Gross Solids Removal Devices*” prepared for CALTRANS by Bassam A. Younis, Professor, Department of Civil and Environmental Engineering, UC Davis, May 2005, Report #CTSW-RT-05-73-18.1.

**Table 1. Simulated Trash Composition**

Type of Material	Number of Pieces Run 1	Number of Pieces Run 2	Number of Pieces Run 3
Shredded cardboard	35	70	105
Cigarette butts	250	500	750
Cloth strips	20	40	60
Aluminum foil (balls)	10	20	30
Aluminum foil (strips)	15	30	45
Plastic film strips	30	60	90
Chopped plastic	40	80	120
Styrofoam peanuts	75	150	225
Wooden popsicle sticks	56	112	168
Shredded paper	100	200	300

#### 3.2 Trash Loading

Trash material listed in **Table 1** was preloaded into the AS-3s prior to initiating flow for each of the three performance runs. The material was contained in three separate 0.67 cubic foot containers (5 gallon buckets) to facilitate the loading process. Trash was loaded directly into the standing water of the treatment area (influent side of arched baffle and screen) for each of the three consecutive trash retention test runs. The static water level in the unit corresponds to the invert elevations of both the influent and effluent piping. Test runs were performed on a cumulative trash loading basis. That is, the second performance run included the trash volume from the first run as well as a second addition of the trash test material. Likewise, the third run included a third addition of trash material such that the previously retained material from both runs 1 and 2 were included in run 3.

#### 4.0 TRASH RETENTION TESTING

A total of three trash retention test runs were performed at three different screen loading rates ( $\text{gpm}/\text{ft}^2$ ) under the direct observation of an independent observer representing AIRL, Inc. of Cleveland, Tennessee (<http://www.airlonline.com/>). AIRL holds a number of industry, state and federal certifications for analytical testing. A copy of the AIRL report for this trash retention testing program is attached hereto.

##### 4.1 Retention Run 1 at 21 $\text{gpm}/\text{ft}^2$

Prior to initiating retention run 1, the contents of the first 0.67 cubic feet of trash material was poured into the AS-3s and stirred to achieve a reasonably even distribution of the material across the treatment area of the swirl chamber (**Figure 5**). The pump was then activated and ramped up to 21  $\text{gpm}/\text{ft}^2$  of screen area. Run 1 was 15 minutes in duration. At the conclusion of the test run period the pump was deactivated and circulation within the swirl chamber came to a stop. No trash was observed in the effluent during the flow period nor was trash captured in the discharge net. The 2,700 gallon water tank contained no trash material.



Figure 5. Trash material preloading for run 1.

##### 4.2 Retention Run 2 at 52 $\text{gpm}/\text{ft}^2$

Once all residual flow from run 1 ended a second 0.67 cubic feet of trash material was added to the swirl chamber and stirred as described above (**Figure 6**). It was noted by this time that cloth strips, foil, many paper strips and a number of cigarette butts had accumulated at the base of the swirl chamber as reported by AIRL. There was still some floatables present in the swirl chamber. Flow was ramped up to 52  $\text{gpm}/\text{ft}^2$  for the second retention run. Flow was stopped after 15

minutes and circulation came to an end. Again, no trash was observed in the effluent during the flow period, nor was trash observed in the discharge net or water supply tank.



Figure 6. Trash material preloading for run 2.

#### 4.3 Retention Run 3 at 98 gpm/ft<sup>2</sup>

After the residual circulation flow following run 2 came to an end, the third 0.67 cubic feet of trash material was added to the swirl chamber and stirred (**Figure 7**). Flow was ramped up to 98 gpm/ft<sup>2</sup> and another 15 minute flow period was conducted. No trash was observed in the effluent, the discharge net or the water tank.





Figure 7. Trash material preloading for run 3.

#### 4.4 Trash Inventory

At the conclusion of the third retention run the AS-3s was drained of water and the trash material that had been added to the test unit was inventoried and compared to the pre-test inventory of the total trash material. **Figure 8** displays the post-testing trash material arranged according to material type. The trash inventory was identical for the pre-test and post-test material; thus, 100% of the trash that was added to the AS-3 was retained during the three performance runs.



Figure 8. Inventory of post-testing trash material arranged according to material type.

## 5.0 CONCLUSION

Testing was performed at the AquaShield™ laboratory facility to document the trash retention capability of a full scale, commercially available Aqua-Swirl® Model AS-3s. All testing was performed under the direction of an independent observer. In addition to the standard AS-3 configuration, the AS-3s test unit utilized a trash retention screen having an array of 4.7 mm diameter perforations. The screen extends below the inner arched baffle and is capped at the bottom to prevent trash from escaping the unit.

Three trash retention test runs of 15 minutes each (total of 45 minutes) were conducted at loading rates ranging from approximately 21 gpm/ft<sup>2</sup> to 98 gpm/ft<sup>2</sup> of screen area . The simulated trash material contained a variety of materials commonly found in stormwater runoff including cardboard, cigarette butts, cloth, aluminum foil, plastic, styrofoam, popsicle sticks and paper.

This testing program demonstrated that the Aqua-Swirl® Model AS-3s using the trash retention screen achieved full trash capture and qualifies as a full-capture device under the California Trash TMDL.

All Aqua-Swirl® systems are designed according to site-specific conditions such that the design treatment capacity is not less than the peak flow resulting from a one-year, one-hour storm in the sub-drainage area. An Aqua-Swirl® sizing chart is shown below in **Table 2**.

**Table 2. Aqua-Swirl® Sizing Chart**

<b>Model</b>	<b>Diameter (ft)</b>	<b>Treatment Capacity (cfs)</b>	<b>Screen Area (ft<sup>2</sup>)</b>
AS-2	2.5	1.1	5.0
AS-3	3.5	2.1	9.6
AS-4	4.5	3.5	16.0
AS-5	5	4.4	20.2
AS-6	6	6.3	28.9
AS-7	7	8.6	39.4
AS-8	8	11.2	51.3
AS-9	9	14.2	65.0
AS-10	10	17.5	80.1
AS-11*	11	21.2	97.1
AS-12*	12	25.2	115.4
AS-13*	13	29.6	135.6
AS-XX**	Custom		



## 6.0 APPLICANT PROFILE

AquaShield™, Inc. manufactures stormwater treatment systems used worldwide to protect sensitive receiving waters from the harmful effects of stormwater. The commitment of AquaShield™ to provide quality environmental solutions began in the early 1980s with its founder solving surface water and groundwater contaminant issues at industrial and commercial facilities through his previously owned environmental consulting/contracting companies. The first product was a catch basin insert introduced in 1997. Subsequently, a stormwater filtration system was introduced in 1999. Early in 2000, AquaShield™ formed its corporate headquarters in Chattanooga, Tennessee and began its campaign as the vanguard for treatment of stormwater and industrial runoff for both domestic and international markets. Recognition of the increasing compliance standards for waterborne pollutants set AquaShield™ apart in a fast growing industry. AquaShield™ received patents for treatment systems that integrated hydrodynamic swirl separation technology for pretreatment with high flow filtration technology in a single device. In 2001, the patented standalone Aqua-Swirl® hydrodynamic swirl concentrator was introduced to meet the increasing requests for primary pollutant removal of sediment and floatable debris and oils.

AquaShield™ offers essential alternatives for treating stormwater and industrial runoff: the Aqua-Swirl®, the Aqua-Filter™ and the Aqua-Guardian™. Other derivatives of these core products have been adapted for customers needing further enhanced water treatment. These products distinguish themselves from other systems with their high performance, lightweight construction material, providing unmatched flexibility and adaptation to site-specific conditions. The Aqua-Swirl® and Aqua-Filter™ are available in both high density polyethylene (HDPE) and Polymer Coated Steel (PCS). Each product arrives at the project job site completely assembled and ready for installation. Leak tests are performed for every structure prior to shipment to ensure the product's integrity. A limited one year warranty applies to all AquaShield™ products.

Comprehensive information about AquaShield™ and our products is available at [www.aquashieldinc.com](http://www.aquashieldinc.com).

*Attachment: AIRL Report (1 page)*

**A. I. R. L. Inc.**

1550 37<sup>th</sup> Street, NE, Cleveland, TN 37312  
Phone: (423) 476-7766 or Fax: (423) 476-7714

Customer: AquaShield, Inc.

Reference Laboratory ID: 01/27/17 California Trash Test Observation

296201

Case Narrative:

01/27/17 I arrived at AquaShield Laboratory at 8:30am, to observe filtration testing of trash. I first observed that trash loads were in three different five gallon buckets each containing counts as follows:

Shredded cardboard-35pcs.

Cigarette butts-250pcs.

Cloth strips-20pcs.

Aluminum foil-10 balls, 15 strips

Plastic film strips-30pcs.

Chopped plastic-40pcs.

Styrofoam peanuts-75pcs.

Wooden Popsicle sticks-56pcs.

Shredded paper-100pcs

As testing began a five gallon bucket of trash was emptied and stirred into Aqua-Swirl, a flow of 21gpm/sq.ft +/- was obtained. Flow was maintained for fifteen minutes. After the fifteen minute interval flow was stopped and circulation ended. At this time second load of trash was stirred into Aqua-Swirl and flow re-adjusted to 52gpm/sq.ft and ran for another fifteen minutes. It was noted that at this time cloth strips and foil as well as paper strips and some cigarette butts were obtained on the filter. After this fifteen minute interval the flow was stopped again and circulation ended. When all trash and water became still the third load of trash was mixed into the Aqua-Swirl. Flow was then adjusted to 98gpm.sq.ft +/- and ran for a third fifteen minute interval.

After the third and final run Aqua-Swirl was drained and trash was then counted to calculate retention.

All trash introduced into the Aqua-Swirl was retained by the filter, 100% retention of trash was achieved.

Pictures of testing observations are attached.

Thank You,  
Sherry Williams, A.I.R.L.



QA/QC Procedures required by the Method(s) were followed unless otherwise noted. Performance and acceptance standards for required QA/QC procedures were achieved unless otherwise noted. No significant modifications have been made to the Method(s). I attest that, based upon my inquiry of those individuals immediately responsible for reviewing the information, the material contained in this report is, to the best of my knowledge and belief, accurate and complete.

These results relate only to the items tested. This report shall not be reproduced except in full and with permission of this laboratory. The laboratory retains sole ownership of data until full reimbursement has been made.