



June 29, 2018

Mr. Jaime Favila
California State Water Resources Control Board
Division of Water Quality
P.O. Box 100
Sacramento, CA 95812-100

Re: Application for Trash Treatment Control Device - Bio Clean® Modular Wetland System (MWS) - Revised

Dear Mr. Favila,

Bio Clean® is pleased to submit this revised application for the Modular Wetland System (MWS) for Certification as a Full Capture System - Trash Treatment Control Device. Documentation for this application is being submitted in accordance with the California State Water Resources Control Board *Trash Treatment Control Device Application Requirements* document that includes the following minimum requisite sections:

1. Cover Letter
2. Table of Contents
3. Physical Description
4. Installation Information
5. Operation and Maintenance Information
6. Reliability Information
7. Field/Lab Testing Information and Analysis

Please contact me with any questions or should additional information be required. Thank you for your consideration of this application.

Regards,

Zachariha J. Kent
Vice President of Product Development & Regulatory Compliance
Bio Clean®, A Forterra Company

1.0 COVER LETTER

1.A. A general description of the Device;

The Modular Wetlands[®] is a multi-stage, storm water treatment system that incorporates screening, sedimentation, filtration, adsorption, and biological remediation for removal of trash, floating and neutrally buoyant debris, suspended sediments, nutrients, heavy metals, and hydrocarbons from the storm water. The Device consists of a settling chamber, a cartridge-based media pre-filter, a wetland filtration chamber and an outlet chamber all housed in a precast concrete vault. The Modular Wetlands[®] is available in several configurations including configurations that allow for grated inlet flow, curb inlet flow, pipe or roof drain flow, and online or offline flow. All design flows must pass through a pre-filter which contains a series of screens that decrease in size to an aperture not greater than 3.175mm ensuring capture of all particles 5mm in size or larger. Captured trash and debris is stored in the pretreatment chamber which is hydraulically isolated from the outlet of the Device by screens.

1.B. The applicant's contact information and location;

California Contact:

William Harris
National Product Sales Director
Bio Clean[®], A Forterra Company
398 Via El Centro
Oceanside, California
(760) 205-2185
William.Harris@forterrabp.com

Corporate Contact:

Zachariah J. Kent
Vice President of Product Development & Regulatory Compliance
Bio Clean[®], A Forterra Company
511 East John Carpenter Freeway
Irving, Texas 75062
(760) 433-7640
Zach.kent@forterrabp.com

1.C. The Devices' manufacturing location;

The stormwater division of Bio Clean® is supported through manufacturing by its parent company Forterra Building Products. Forterra Building Products currently has 88 manufacturing locations throughout the country. Three facilities currently provide support for the California market and are listed below:

Forterra Building Products
Drainage Pipe and Products Division
7020 Tokay Avenue
Sacramento, California 95828

Forterra Building Products
Drainage Pipe and Products Division
26380 Palomar Road
Menifee, California 92585

Forterra Building Products
BioClean Stormwater Management Systems
398 Via El Centro
Oceanside, California 92058

1.D. A brief summary of any field/lab testing results that demonstrates the Device functions as described within the application;

Bio Clean® has conducted numerous field and laboratory tests on the Modular Wetlands® system. None of these tests contained a technical component or requirement to monitor the removal of trash or specifically the capture of a 5mm particle or greater. However, the testing monitored for removal of fine and dissolved pollutants and the presence of trash in the effluent would be a cause for concern and potentially non-conformance to the test protocols. One of the most rigorous field monitoring studies conducted on the Modular Wetlands® system was the Washington Department of Ecology Field Monitoring Study Conforming to TAPE (Technology Assessment Protocol Ecology). This field monitoring study spanned a period of just over 13 months and included 28 separate sampled storm events. No evidence of trash or debris in the effluent was detected. A copy of the TER (Technical Evaluation Report) is included with this application in Appendix F.

Additionally, the Modular Wetlands® system includes a series of screens, the last in the series containing openings not greater than 3.175mm thereby negating the need for testing but also ensuring Full Capture of particles 5mm or greater.

1.E. A brief summary of the Device limitations, and operational, sizing, and maintenance considerations;

The Modular Wetlands® is a pre-engineered, multi-stage, storm water treatment system designed to meet site-specific water quality treatment requirements. Conformance with the Engineer's Plans and Specifications is essential to ensure proper operation and function of the Device.

Bio Clean® manufactures the Modular Wetlands® using a precast concrete housing, stainless steel and durable plastic internal components. The materials selected serve a wide variety of applications and are the most durable materials available for these type devices. Adherence to minimum and maximum installation depths and installation recommendations are required to ensure the design service life of the Device is maintained.

Modular Wetlands® systems should be sized to meet site and region specific water quality objectives and requirements. Systems that are not designed and installed in conformance within the maximum treatment flow rate and maximum bypass flow rate limits can cause adverse hydraulic conditions. Additionally, non-conformance with the Device design limits may cause non-compliance with the water quality objectives and requirements.

All structural, post-construction Best Management Practices require routine and scheduled inspection and maintenance. Inspection and maintenance is facilitated by large hatches for access to the treatment bays and perimeter mounted screens for access to the trash and sediment storage areas. System design should consider accessibility of the Device for inspection and maintenance. Design considerations for maintenance frequency should also be a consideration.

1.F. A description or list of locations, if any, where the Device has been installed. Include the name and contact information of as many as three municipality(s) purchasing the Device, and

Installation 1

Project Name: Ontario Soccer Park
Device: 8ea MWS Linear Curb and Vault Style
Agency: City of Ontario, CA
Contact: Mr. Stephen Wilson, CPESC/QSD
Environmental Water/Wastewater Engineer
(909) 395-2389
swilson@ontarioca.gov

Installation 2

Project Name: Oceanside Harbor
Device: 1ea MWS Linear Curb Style
Agency: City of Oceanside, CA
Contact: Mr. Mo Lahsaie, Ph.D., REHS
Clean Water Coordinator
(760) 435-5803
mlahsaie@ci.oceanside.ca.us

Installation 3

Project Name: Moffett Drive and Legacy Road Extension Roadway Construction
Device: 18ea MWS Linear Curb Style
Agency: City of Tustin, CA
Contact: Mr. Alex Waite
Environmental Compliance Specialist
(714) 573-3305
awaite@tustinca.org

1.G. The certification below:

I certify under penalty of law that this document and all attachments were prepared under my direction or supervision in accordance with a system designed to assure that qualified personnel properly gather and evaluate the information submitted. Based on my inquiry of the person or persons that manage the system or those persons directly responsible for gathering the information, to the best of my knowledge and belief, the information submitted is, true, accurate, and complete. I am aware that there are significant penalties for submitting false information, including the possibility of fine and imprisonment for knowing violations.



Edward Sexe, P.E., Senior Vice President and General Manager

06/29/2018

Date

THIS PAGE INTENTIONALLY LEFT BLANK

2.0 TABLE OF CONTENTS

Contents

1.0	COVER LETTER.....	2
1.A.	A general description of the Device;.....	2
1.B.	The applicant's contact information and location;	2
1.C.	The Devices' manufacturing location;	3
1.D.	A brief summary of any field/lab testing results that demonstrates the Device functions as described within the application;.....	3
1.E.	A brief summary of the Device limitations, and operational, sizing, and maintenance considerations;.....	4
1.F.	A description or list of locations, if any, where the Device has been installed. Include the name and contact information of as many as three municipality(s) purchasing the Device, and	4
1.G.	The certification below:	5
2.0	TABLE OF CONTENTS.....	7
3.0	PHYSICAL DESCRIPTION	9
3.A.	Description on how the Device works to trap all particles that are 5 mm or greater in size and how it is sized for varying flow volumes;.....	9
3.B.	Design drawings for all standard Device sizes including dimensions, and alternative configurations;.....	13
3.C.	Photographs, if any, of pre- and post-installation examples; and	14
3.D.	Alternative Configurations;	16
3.E.	Engineering plans/diagrams for a typical installation;.....	16
3.F.	The Device maximum trash capture capacity;.....	16
3.G.	The Device hydraulic capacity (flow in cfs) at its maximum trash capture capacity for all standard Device sizes;.....	17
3.H.	Each material and material grade used to construct the Device (stainless steel, plastic, etc.); 17	
3.I.	Conditions under which the Device re-introduces previously trapped trash;.....	17
3.J.	Estimated design life of the Device;.....	18
3.K.	If the Device is substantially similar to a currently listed Certified Device(s), name the Certified Device(s) and identify the substantial similarities and any minor changes in materials, material thickness, structural assembly, etc. Explain how these minor changes in	

your Device will impact performance as compared to the substantially similar Certified Device.	18
4.0 INSTALLATION INFORMATION	18
4.A. Installation considerations;	18
4.B. Device installation procedures; and	18
4.C. Methods for diagnosing and correcting installation errors.....	19
5.0 OPERATION AND MAINTENANCE INFORMATION.....	20
5.A. Device inspection frequency considerations and inspection procedures;	20
5.B. Maintenance frequency considerations, maintenance procedures, and a description of necessary equipment and materials for maintenance;	21
5.C. Effects of delayed maintenance on Device structural integrity, performance, odors;.....	23
5.D. Vector Control Accessibility:	23
6.0 RELIABILITY INFORMATION	26
6.A. Estimated design life of Device components before major overhaul;	26
6.B. Device sensitivity to loadings other than trash (i.e., leaves, sediment, etc.);.....	27
6.C. Warranty Information; and.....	27
6.D. Customer support information.	27
7.0 FIELD/LAB TESTING INFORMATION AND ANALYSIS.....	27
APPENDIX A.....	29
APPENDIX B.....	63
APPENDIX C.....	70
APPENDIX D.....	84
APPENDIX E.....	105
APPENDIX F.....	107

3.0 PHYSICAL DESCRIPTION

3.A. Description on how the Device works to trap all particles that are 5 mm or greater in size and how it is sized for varying flow volumes;

The Modular Wetlands[®] is a multi-stage, storm water treatment system that incorporates screening, sedimentation, filtration, adsorption, and biological remediation for removal of trash, floating and neutrally buoyant debris, suspended sediments, nutrients, heavy metals, and hydrocarbons from the storm water. The Device consists of a settling chamber, a cartridge-based media pre-filter, a wetland filtration chamber and an outlet chamber all housed in a precast concrete vault. The Modular Wetlands[®] is available in several configurations including configurations that allow for grated inlet flow, curb inlet flow, pipe or roof drain flow, and online or offline flow. All design flows must pass through a pre-filter which contains a series of screens that decrease in size to an

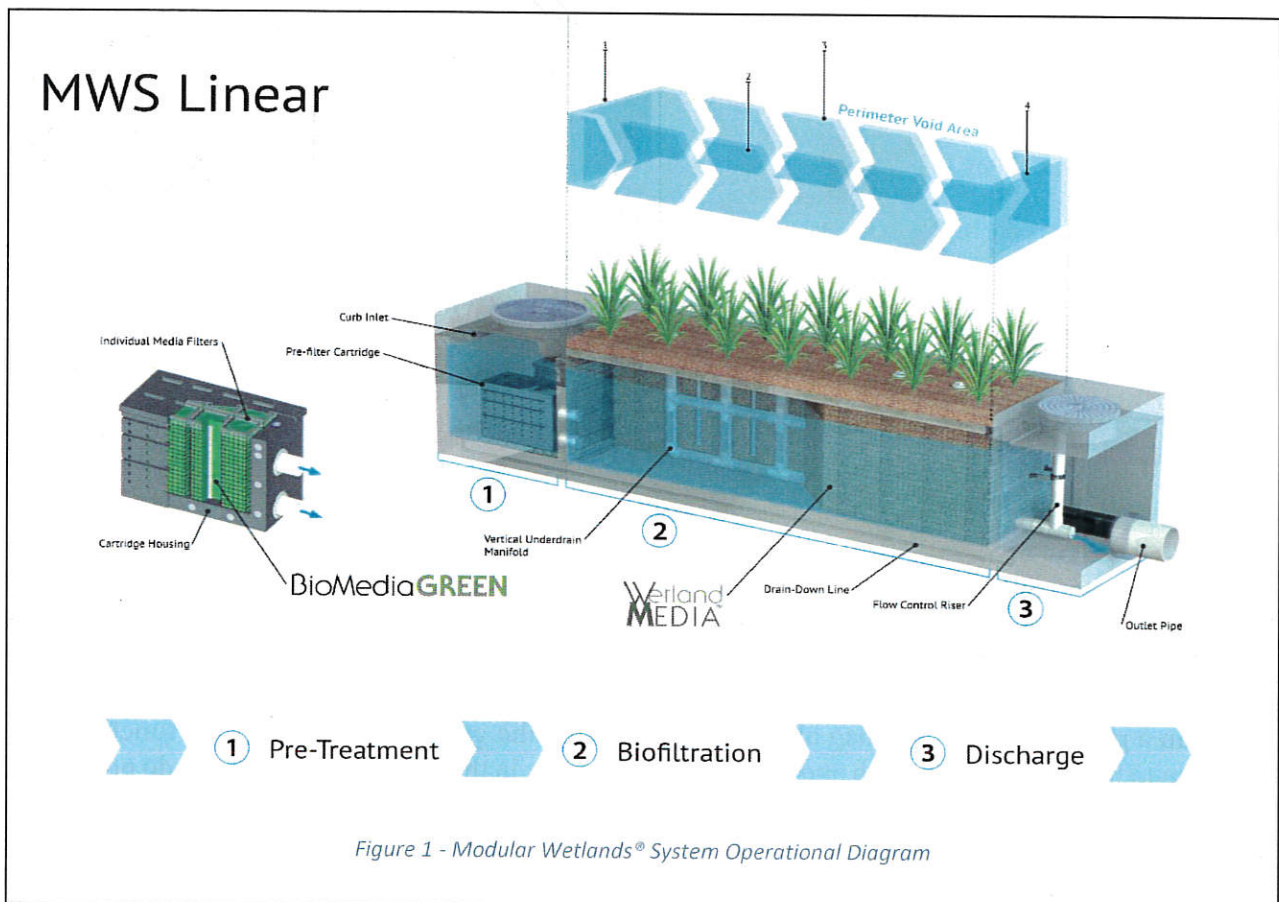

Figure 1 - Modular Wetlands[®] System Operational Diagram

aperture not greater than 3.175mm ensuring capture of all particles 5mm in size or larger. Captured trash and debris is stored in the pretreatment chamber which is hydraulically isolated from the outlet of the Device by screens.

Figure 1 illustrates the operation of the Modular Wetlands[®] system under normal flow conditions. Storm water flows must pass through a series of three treatment chambers prior to exiting the Device. Each of the three chambers provides a critical function to the multi-stage process for treating the storm water.

The treatment process begins when water enters the pre-treatment chamber of the Modular Wetlands[®] system. Water enters the Device either through a grated inlet, a curb inlet or through piped flows or a combination of the three depending on the designed configuration. Before the water may exit to the second treatment chamber, it must first pass through the pre-filter, which is comprised of a series of screens and granular media. See Figure 2. The pre-filter assembly has a main housing made from High Density Polyethylene. The housing is perforated and slotted and acts as a screen to block large material from entering the pre-filter. The openings in the housing

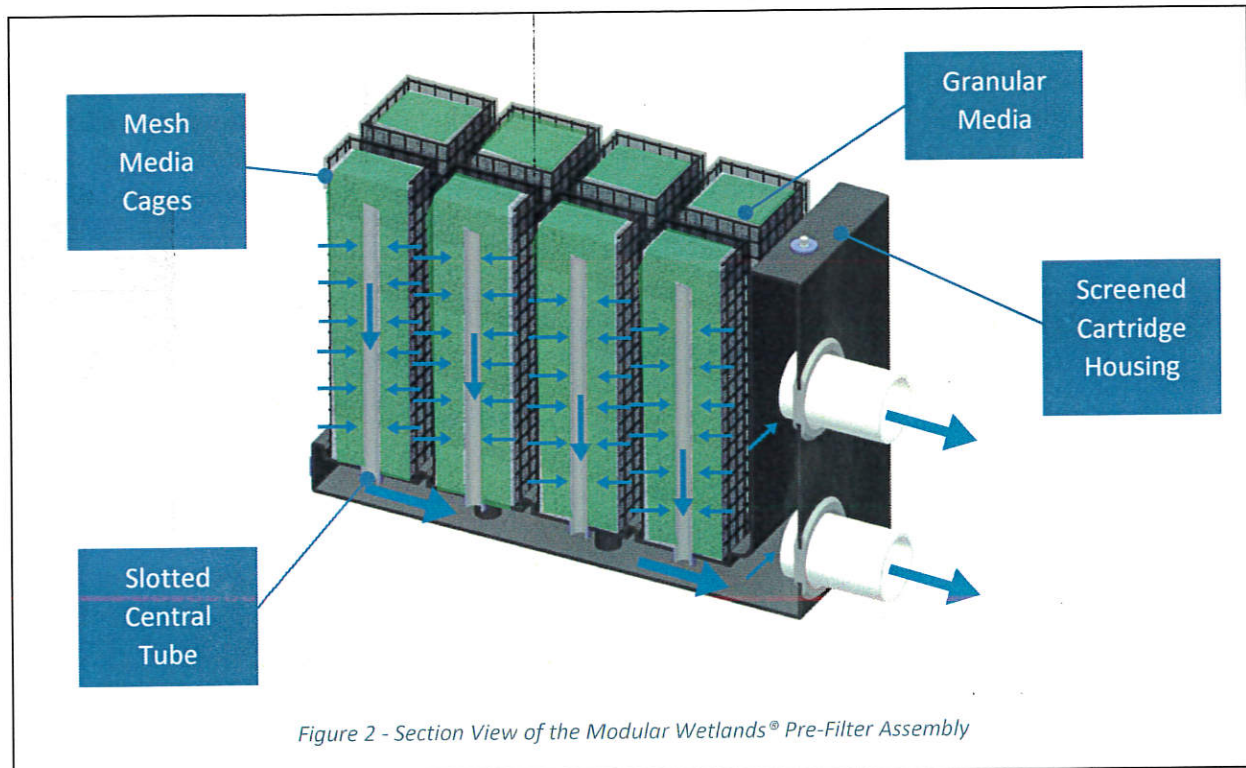
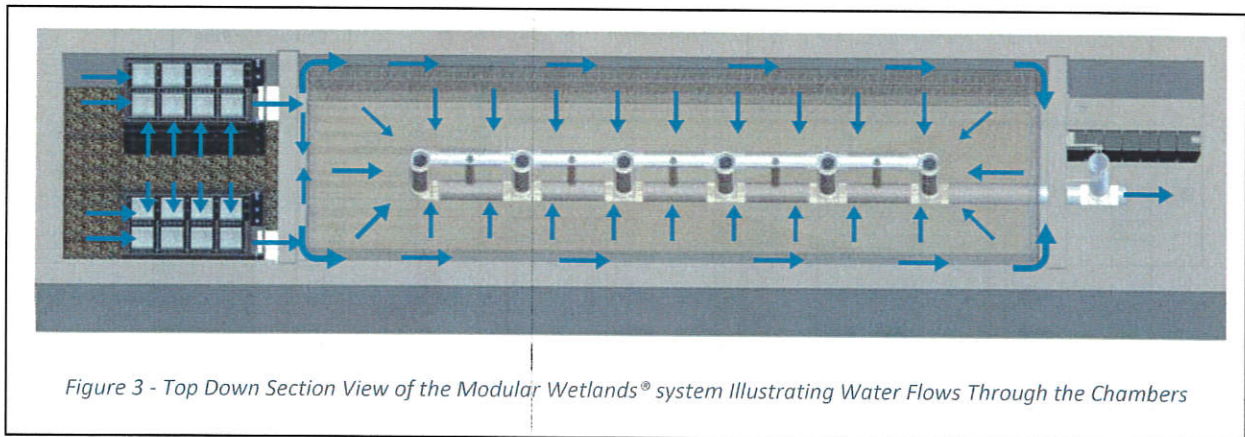

Figure 2 - Section View of the Modular Wetlands[®] Pre-Filter Assembly

are not larger than 0.75in diameter. The storm water progresses through the pre-filter and encounters the second screen. This screen is made from a vinyl coated wire mesh with openings not greater than 0.5in square. The mesh cage serves to hold the granular media and serves to block a slightly smaller trash and debris particle than the first screen. The media is additionally contained within a polyester bag. The bag also serves to contain the granular media but also functions as a screen to block additional trash and debris. The openings in the knitted polyester bag do not exceed 10mm in any given direction. The storm water next encounters the media. Since the media is in a granular form, it also serves to screen particles from the storm water. After treatment by the media, the water is collected in each cartridge by a central tube. The tube is made from a slotted PVC pipe and the slots have openings not greater than 3.175mm. All the tubes connect to a lower channel at the bottom of the pre-filter assembly and water is collected in this location prior to exiting the pre-treatment chamber. All flows must pass through the media and screens prior to

exiting the pre-treatment chamber thus ensuring all particles 5mm or greater in size are captured for all flows less than the maximum design flow.

The storm water exits the pre-filter chamber via a 4-inch diameter PVC pipe. One or more pre-filter assemblies may be utilized and each will convey water to the biofiltration chamber via these 4-inch diameter pipes. The biofiltration chamber consists of a proprietary wetland media, growing media, and plantings. The chamber provides an advanced level of treatment for the storm water that includes processes such as filtration, adsorption, absorption, denitrification, and



bioaccumulation. Once water enters the chamber it is routed to the perimeter of the chamber through a system of vertically arranged drain panels. This ensures even dispersal around the perimeter of the media bed. Water enters the media bed horizontally ensuring a large surface contact area, which minimizes blockage of the media. Water must pass through a minimum 20-inch thick depth of media prior to entering an assembly of perforated collection pipes at the center of the chamber. In addition, the media is contained within a polyester netting material with openings no larger than 5.0 mm in size. All water must pass through the netting and the media. There is no flow path that does not pass through the netting or media ensuring all water that enters the biofiltration chamber is screened and filtered.

The final chamber of the Modular Wetlands® system is the discharge chamber and as the name suggests this chamber regulates the discharge of water from the Device. An orifice plate or valve in this chamber is factory set to regulate the water discharge from the Device. Although this chamber provides no direct treatment, it does determine the amount of water that can be processed through the Modular Wetlands® system. The orifice plate and/or valve are set so that the design Maximum Treatment Flow Rate is not exceeded for the Device.

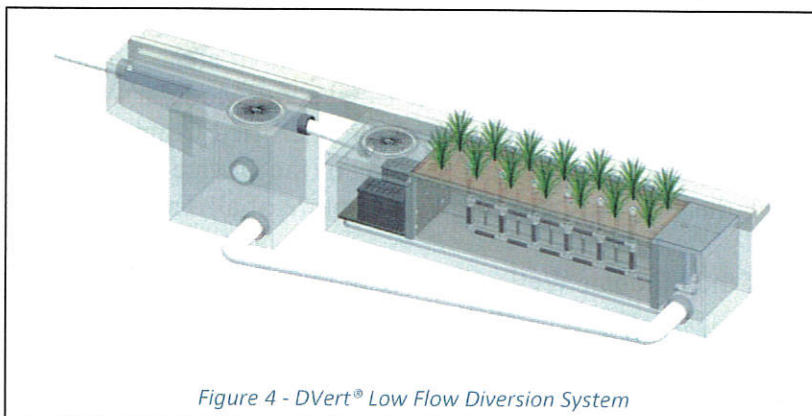

The Modular Wetlands system may be utilized as an online or offline system. Systems that are designed for offline operation must ensure that the diversion mechanism utilized diverts all flows up to the flows generated by the Full Capture Design

Storm. Figure 4 is an illustration of BioClean's® DVert® low flow diversion system. This system routes flows for treatment to the Modular Wetlands® and all flows greater than those from the Design Storm are routed around the system via a bypass pipe. This ensures that large flows do not enter the Device thus eliminating resuspension of previously captured trash and debris from the

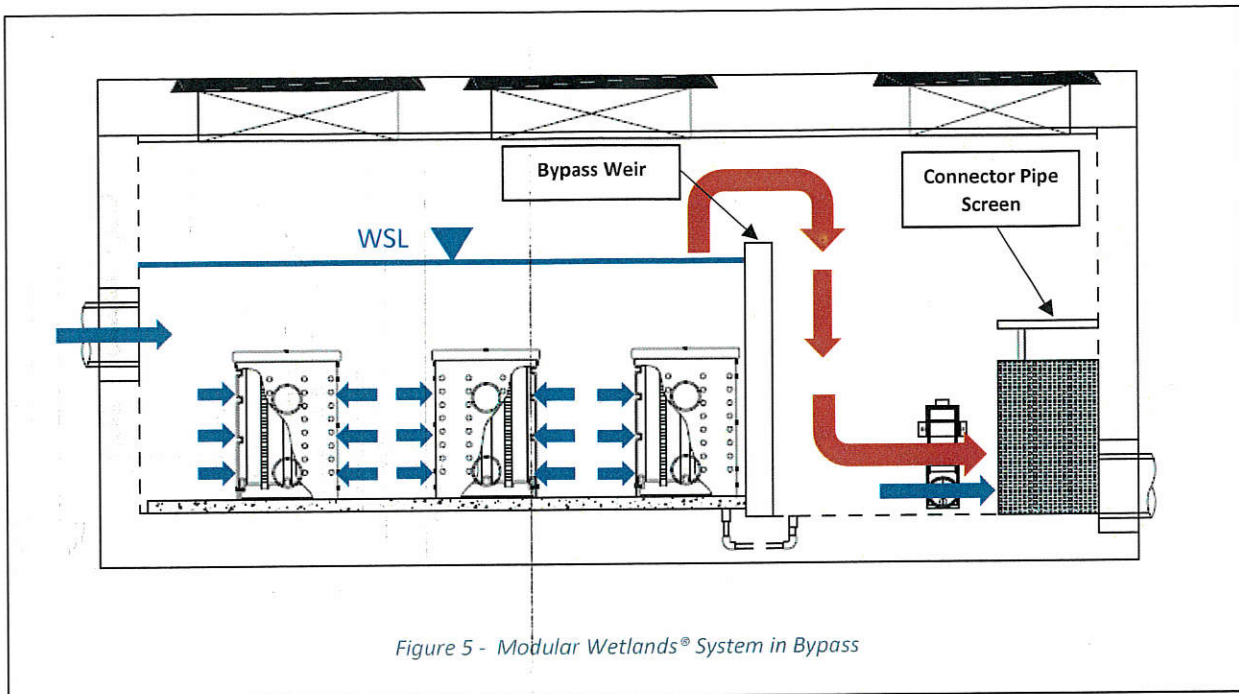

pre-treatment chamber from these peak flows.

When utilized as an online Device, the Modular Wetland® System is designed to internally bypass. The design of the Device allows flow in excess of the maximum treatment flow rate to bypass the wetlands treatment chamber while still retaining the Full Capture properties of the Device. Figure 5 illustrates a typical Modular Wetland® System vault configured for internal bypass. Flow enters the vault on the left side of the vault as illustrated in the Figure with the large blue arrow. Stormwater may enter through one or multiple pipes, grate or curb inlets. Flows less than the maximum treatment flow rate for the Device are maintained at a level beneath the top of the bypass weir and all flows pass through the pre-treatment and wetlands treatment chambers. Flows in excess of the maximum treatment flow rate will cause the water level in the pre-treatment chambers to overtop the bypass weir. This flow path is illustrated in the Figure with the red arrows. These flows are not pre-treated and do not pass through the wetlands treatment area. To prevent the release of trash and to maintain Full Capture properties for the Device, the Modular Wetland® System configured for internal bypass is equipped with a Full Capture Certified Connector Pipe Screen (CPS). The Full Capture Certified CPS is installed at the outlet of the Device and all flows that enter the Device must pass through the CPS thus ensuring Full Capture of all Trash.

A video demonstrating the operation of the Modular Wetlands® can be found at the link below:

<https://vimeo.com/211548965>

Modular Wetlands® Characteristics and Capacity Table
California Full Capture Certified Capacities
Table 1

MWS Model	MTFR (Trash/Sediment)	Trash Storage Capacity	Sediment Storage Capacity
	(cfs)	(ft ³)	(ft ³)
MWS-L-4-4	0.052	10.7	2.7
MWS-L-4-6	0.073	15.0	3.7
MWS-L-4-6.33	0.073	16.7	4.2
MWS-L-4-6.5	0.073	17.6	4.4
MWS-L-4-8	0.115	19.8	4.9
MWS-L-4-13	0.144	32.0	8.0
MWS-L-4-15	0.175	32.0	8.0
MWS-L-4-17	0.206	32.0	8.0
MWS-L-4-19	0.237	32.0	8.0
MWS-L-4-21	0.268	32.0	8.0
MWS-L-6-8	0.147	30.5	7.6
MWS-L-8-8	0.23	36.7	9.2
MWS-L-8-12	0.346	56.3	14.1
MWS-L-8-16	0.462	85.7	21.4
MWS-L-8-20	0.577	94.0	23.5
MWS-L-8-24	0.693	123.4	30.8
MWS-L-10-20	0.693	90.0	22.5

3.B. Design drawings for all standard Device sizes including dimensions, and alternative configurations;

Design drawings for all standard devices and configurations are included in Appendix A.

3.C. Photographs, if any, of pre- and post-installation examples; and

Photographs of the Modular Wetlands® in various stages of installation and operation are included below:



Figure 6 – Modular Wetlands® Offload From Truck

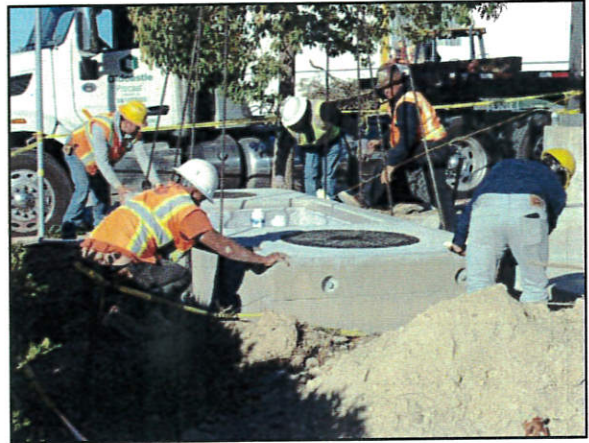

Figure 9 - Modular Wetlands® Placement



Figure 7 - Modular Wetlands® Offload From Truck



Figure 10 - Modular Wetlands® Placement



Figure 8 - Modular Wetlands® Placement



Figure 11 - Modular Wetlands® Placement



Figure 12 - Modular Wetlands® in Operation



Figure 15 - Pre-Treatment Chamber with Trash and Debris



Figure 13 - View of Pre-Treatment Chamber



Figure 16 - Maintenance of Modular Wetlands® System



Figure 14 - Pre-Treatment Chamber with Trash and Debris



Figure 17 - Maintenance of Modular Wetlands® System



Figure 18 - Maintenance of Modular Wetlands® System



Figure 20 - Pre-Treatment Chamber Post-Maintenance



Figure 19 - Maintenance of Modular Wetlands® System

3.D. Alternative Configurations;

Alternate configurations of the Modular Wetlands® have been included in Appendix A.

3.E. Engineering plans/diagrams for a typical installation;

Typical installation details are included in the Installation Manual located in Appendix C.

3.F. The Device maximum trash capture capacity;

Table 1 lists the trash capture volume (ft³) retained by each Modular Wetlands® model. The trash capture volumes listed are maximum volumes that can be removed without a reduction in treatment performance and considers full retention of trash with no re-entrainment under peak flow conditions.

3.G. The Device hydraulic capacity (flow in cfs) at its maximum trash capture capacity for all standard Device sizes;

The maximum hydraulic capacity at the maximum trash capacity is listed as the MTFR (Trash) in Table 1.

3.H. Each material and material grade used to construct the Device (stainless steel, plastic, etc.);

The Modular Wetlands® treatment system is constructed of high strength, durable materials and components that ensure a long design and service life for the Device. Appendix B of this submittal includes a detailed Specification for the Modular Wetlands® Device which includes material specifications. Key materials and components are additionally listed below:

- Structure – The Modular Wetlands® and all of its components are self-contained within a concrete structure constructed with a minimum 28 day compressive strength of 5,000psi or greater, with reinforcing steel per ASTM A 615, Grade 60, and is designed to support a minimum loading of H-20 per AASHTO.
- Pre-Treatment Cartridge Screened Housing – The filter housing is made from High Density Polyethylene (HDPE) and screened openings are no larger than 0.75in diameter.
- Mesh Media Cages – The pre-treatment media is housed inside of mesh screens made from 14 gauge vinyl coated mesh with openings no larger than 0.5in square.
- Filter Media Bag – The media is housed in bags made from 100% polyester with openings sized not greater than 9mm and knitted at 9 holes/inch.
- Filter Central Tube – The central tube for the pre-treatment filter is made from SCH80 PVC tube containing slots not greater than 0.125in (3.175mm) in size and spaced 120 degrees apart every 3/16 in.
- Media – The media consists of expanded and vitrified ceramic material conforming to ASTM C330, ASTM C331, and AASHTO M195.
- Planting – The plants in the main treatment bay are drought tolerant and native.
- Plant Support Media – The growing media for the plantings is made from melted basalt spun into fibers and formed into blocks that contain no chemicals, fertilizers or organic material and has a void percentage of 80%.

3.I. Conditions under which the Device re-introduces previously trapped trash;

The Modular Wetlands® system has been designed to remove and permanently retain all trash and debris (and other pollutants) that are 5mm in size or larger. Conditions under which the Device re-introduces previously trapped trash are listed below:

- If the device is not properly maintained and trash and debris are allowed to accumulate beyond the prescribed maximum allowable level in the pre-treatment bay, conditions will be present that could cause a re-introduction of trash into the storm drain flows via the bypass mechanism.

- Broken or damaged screens, nets or mesh in the pre-treatment bay can cause an adverse condition that would allow re-introduction of trash and debris into the effluent.
- Missing or un-replaced screens, nets, or mesh after a maintenance service can cause an adverse condition that could re-introduce trash and debris into the effluent of the Device.

3.J. Estimated design life of the Device;

The estimated design life for Modular Wetlands® system is 75 to 100 years. The design life is dependent on the materials utilized as well as the proper application of those materials. Certain components such as the media, media bags, soil, and plantings are consumable materials and are intended to be removed and replaced on a routine bases.

3.K. If the Device is substantially similar to a currently listed Certified Device(s), name the Certified Device(s) and identify the substantial similarities and any minor changes in materials, material thickness, structural assembly, etc. Explain how these minor changes in your Device will impact performance as compared to the substantially similar Certified Device.

The Modular Wetlands® is not similar to any currently listed Certified Devices.

4.0 INSTALLATION INFORMATION

4.A. Installation considerations;

Installation considerations for the Modular Wetlands® are included in the Installation Manual in Appendix C of this Application.

4.B. Device installation procedures; and

Installation requirements and procedures are detailed in the Modular Wetlands® *Installation Guidelines for Modular Wetland System* which has been included in Appendix C of this submittal. The guidelines include requirements and procedures for:

- Delivery & Unloading/Lifting
- Inspection
- Site preparation
- Installation
- Wetland Media Install/Planting
- Installation Details
- Weights and Lifting Details
- Connection Details

In general terms, installation of the Modular Wetlands® system is similar to installation of precast utility vaults and storm drain structures. The components unique to the Modular Wetlands® that make it full capture capable and that provide other pollutant removal capabilities are housed internally in the Modular Wetlands® vault. These internal components are pre-installed at the factory or are sometimes post-installed on site by the manufacturer. No Contractor or Owner installation of these components is required.

Post installation inspection of the Modular Wetlands® is strongly advised. A representative from Bio Clean® is available for on-site inspection as support for the Owner. Inspection should determine if the Modular Wetlands® was installed properly as well as provided in a clean condition with no defects as a result of the installation.

Installation for Trash Capture in association with Full Capture programs, Trash TMDLs, or the Statewide Trash Amendment are often retrofit type installations. Care should be taken to determine existing and as-built conditions to determine if the Modular Wetlands® must be supplied in a unique configuration to meet the retrofit conditions. Consideration must be given to any unique configurations for flow, treatment, and installation.

4.C. Methods for diagnosing and correcting installation errors.

Bio Clean® has a process for design and manufacturer that includes checks and balances to minimize and eliminate errors in the design and manufacturing processes for the Modular Wetlands® systems. This process involves a formal submittal and review of the design and fabrication details for each unit. The Owner has and should take this opportunity to review the proposed Device prior to installation. This process helps to reduce or eliminate errors during installation. In the event an installation error does occur, the error should be documented and reviewed with Bio Clean® and the Contractor immediately upon determination of the error.

Bio Clean® recommends preparing an installation checklist for use during and after installation of the Modular Wetlands® system. The checklist should include key criteria for determination of proper installation. This checklist should be reviewed in its entirety at the completion of the installation and kept as documentation of proper installation. If during the checklist review an error is determined, the documented error should be reported to Bio Clean® as well as the Owner and Engineer. The checklist should include key criteria such as:

- Inlet/Outlet Pipe Size
- Inlet/Outlet Pipe Diameter
- Inlet/Outlet Pipe Material
- Inlet/Outlet Pipe Elevations
- RIM Elevation
- Bedding Elevation
- Bedding and Backfill Type and Compaction
- Concrete Vault Sections Properly Sealed
- Concrete Condition
- Internal Component Condition

- Vault Protected from Construction Runoff
- Plant Condition

Additionally the Modular Wetlands® can be inspected after commencement of operation to determine proper operation.

5.0 OPERATION AND MAINTENANCE INFORMATION

5.A. Device inspection frequency considerations and inspection procedures;

The Modular Wetlands® *Inspection Guidelines for Modular Wetland System - Linear* is included with this submittal in Appendix D. This manual includes detailed requirements and recommendations for inspection of the Modular Wetlands® when used as a Full Capture Trash Treatment Control Device. A summary of the requirements and recommendations are listed below:

Inspection Summary

- Inspect Pre-Treatment Chamber.
- Inspect Biofiltration Chamber.
- Inspect Discharge Chamber.
- Typical inspection interval is six to twelve months.
- Typical inspection time is approximately 15 minutes.

Note:

- Pollutant loading varies greatly from site to site and no two sites are the same. Therefore, the first year requires inspection monthly during the wet season and every other month during the dry season in order to observe and record the amount of pollutant loading the system is receiving.

Inspection Procedures

The Modular Wetlands® system can be inspected through visual observation without entry into the Device. All necessary pre-inspection steps must be carried out before inspection occurs, especially traffic control and other safety measures to protect the inspector and near-by pedestrians from any dangers associated with an open access hatches or manholes. Once these access covers have been safely opened, the inspection process can proceed:

- Prepare the inspection form by writing in the necessary information including project name, location, date & time, unit number and other info.
- Visually observe the conditions of the inside of the Device in each of the treatment chambers noting any anomalies or non-conforming conditions.
- Assess and quantify the amount of trash, debris, and sediment that has accumulated in the pre-treatment chambers and record this information on the inspection form.

- Visually inspect the condition of the pre-treatment screens and media cartridges noting potential clogging as well as color and condition of the media.
- Inspect the biofiltration chamber for plant condition and health of the plants and document with pictures as necessary.
- Inspect the discharge chamber for obstructions to the outlet orifice and outlet pipe. Inspect the water level and drain down filter for signs of proper function. Specific procedures for monitoring the system performance are noted in the installation manual.
- Maintenance should be initiated should any of the following conditions be present;
 - Missing or damaged internal components.
 - Obstruction in the system or it inlet or outlet.
 - Excessive accumulation of trash and debris in the pre-treatment chamber.
 - Excessive accumulation of sediment in the pre-treatment chamber or in the media cartridges.
 - Overgrown vegetation in the biofiltration chamber.
 - Standing water in the pre-treatment chamber or discharge chamber.

5.B. Maintenance frequency considerations, maintenance procedures, and a description of necessary equipment and materials for maintenance;

A full description of the maintenance procedures can be located in the Modular Wetlands® *Maintenance Guidelines for Modular Wetlands System - Linear* included with this submittal in Appendix D. A summary of the key components of the procedures is listed below:

Maintenance Summary

- Remove Sediment from the Pre-Treatment Chamber – Typical maintenance interval is 12 to 24 months – Typical service time is 10 minutes.
- Replace Pre-Filter Cartridge Media – Typical maintenance interval is 12 to 24 months – Typical service time is 10-15 minutes per cartridge.
- Trim Vegetation – Typical maintenance interval is 6 to 12 months – Service time varies.

Maintenance Procedures

The Modular Wetlands® system is maintained by entry into the Device through the access points as well as through ground level maintenance. All necessary pre-inspection steps must be carried out before inspection occurs, especially traffic control and other safety measures to protect the inspector and near-by pedestrians from any dangers associated with an open access hatches or manholes. Additionally, some maintenance activities may require confined space entry. Confined space entry procedures must be strictly adhered to before and during entry into the Device;

Pre-Treatment Chamber (bottom of chamber)

- Remove access hatch or manhole cover over pre-treatment chamber and position vacuum truck accordingly.

- With a pressure washer spray down pollutants accumulated on walls and pre-filter cartridges.
- Vacuum out Pre-Treatment Chamber and remove all accumulated pollutants including trash, debris and sediments. Be sure to vacuum the floor until pervious pavers are visible and clean.
- If Pre-Filter Cartridges require media replacement move onto step 2. If not, replace access hatch or manhole cover.

Pre-Filter Cartridges (including screens)

- After the pre-treatment chamber has been sufficiently cleaned, safely enter pre-treatment chamber.
- Unscrew the two bolts holding the lid on each cartridge filter and remove lid.
- Place the vacuum hose over each individual media filter to suck out filter media.
- Once the majority of filter media has been removed, use a pressure washer to spray down the inside of the cartridge and related screens. Remove the cleaned media cages and place them to the side. Once removed, the vacuum hose can be inserted into the cartridge to vacuum out any remaining material near the bottom of the cartridge.
- Reinstall the media cages and fill them with new media. Replace the cartridge top ensuring bolts are properly tightened.
- Exit the pre-treatment chamber. Replace the access hatch or manhole cover.

Biofiltration Chamber (middle vegetated chamber)

In general, the biofiltration chamber is maintenance free with the exception of maintaining the vegetation. Using standard gardening tools properly trim back the vegetation to healthy levels. The Modular Wetlands® system utilizes vegetation similar to surrounding landscape areas therefore trim vegetation to match surrounding vegetation. If any plants have died replace the dead plants with new ones:

Discharge Chamber (contains drain down cartridge)

- Remove the access hatch or manhole cover over the discharge chamber.
- Enter the chamber to gain access to the drain down filter. Unlock the locking mechanism and lift up the drain down filter housing to remove the used filter block.
- Insert a new filter block and lock the drain down filter housing back in place.
- Replace the access hatch or manhole cover over the discharge chamber.

Record Keeping Maintenance Procedures

- Following maintenance and/or inspection, the maintenance operator shall prepare a maintenance/inspection record. The record shall include any maintenance activities performed, amount and description of debris collected, and condition of the system and its various filter mechanism.

- The Owner shall retain the maintenance/inspection record for a minimum of five years from the date of maintenance. These records shall be made available to the governing municipality for inspection upon request at any time.

Maintenance Equipment and Materials

The following equipment is helpful when conducting a Modular Wetlands® system inspection and maintenance:

- Recording device (pen and paper form, voice recorder, iPad, etc.)
- Suitable clothing (appropriate footwear, gloves, hardhat, safety glasses, etc.)
- Traffic control equipment (cones, barricades, signage, flagging, etc.)
- Manhole hook or pry bar
- Flashlight
- Tape measure
- Measuring stick or sludge sampler
- Confined space entry equipment (if necessary)
- Vacuum truck
- Pressure washer
- 7/16" open or closed end wrench
- Replacement media

5.C. Effects of delayed maintenance on Device structural integrity, performance, odors;

Standardized maintenance frequencies that are suitable for most sites are detailed in Section 5.A. and 5.B. Maintenance frequency however is very site specific depending on pollutant loading. Records from inspections and prior maintenances should be periodically reviewed to assess the appropriateness of the prescribed maintenance frequency.

Delayed or deferred maintenance can cause diminished pollutant removal, re-entrainment of pollutants, in vault and upstream hydraulic impacts, and impacts to water quality.

5.D. Vector Control Accessibility:

Unlike other Full Capture storm water treatment Devices, the Modular Wetlands® system does not require a permanent pool of water to facilitate removal of pollutants. The Modular Wetlands® system utilizes three unique chambers to facilitate pollutant removal which include a pre-treatment chamber, a biofiltration chamber, and a discharge chamber. None of the chambers utilize a permanent pool of water in the pollutant removal process and as a result the Device design does not promote breeding grounds for mosquitoes and other vector. The Device does maintain a dark and damp environment between storm events and if regular inspection and maintenance is not performed the Device could be prone to retain small pools of water. Bio Clean® designed the Modular Wetlands® to minimize the potential for standing water. Additionally, in the event that

access for Mosquito/Vector control is necessary, Bio Clean® has designed the Modular Wetlands® with suitable access for these inspection and treatment activities.

The Modular Wetlands® system utilizes three treatment chambers for treatment. Two of these chambers (pre-treatment chamber and discharge chamber) are subsurface while the third chamber (Biofiltration chamber) is accessible from the ground level. The pre-treatment chamber and the discharge chamber are both provided with a single manhole cover or access hatch located centrally above the chamber. These access points provide for direct access to inspect, and if necessary, to treat for mosquito and vector. Figure 21 is an illustration of these access points of the Modular Wetlands® system. The biofiltration chamber is densely populated with biofiltration media and vegetation. Once populated, the chamber is not accessible by mosquitoes. The chamber is accessible at the ground level for inspection and treatment if necessary.

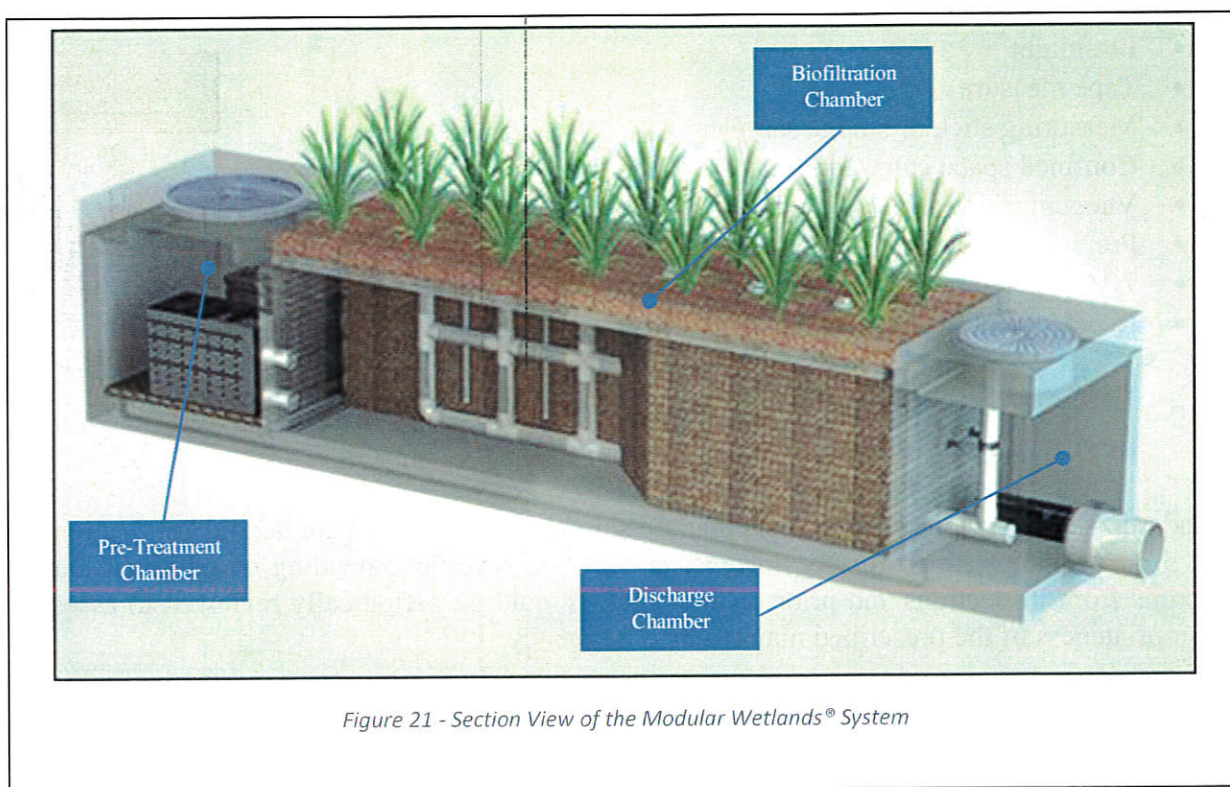

In addition to the access points being conveniently located, the Modular Wetlands® treatment chambers are relatively shallow and conveniently accessible from ground level. The typical depth to the inside bottom of a Modular Wetlands® unit is just over four feet. Figure 23 illustrates the typical depth of a Modular Wetlands® unit. This shallow depth eliminates difficulties experienced with deeper units and also eliminates the use of specialized equipment that may be required for inspection and maintenance of deeper units.

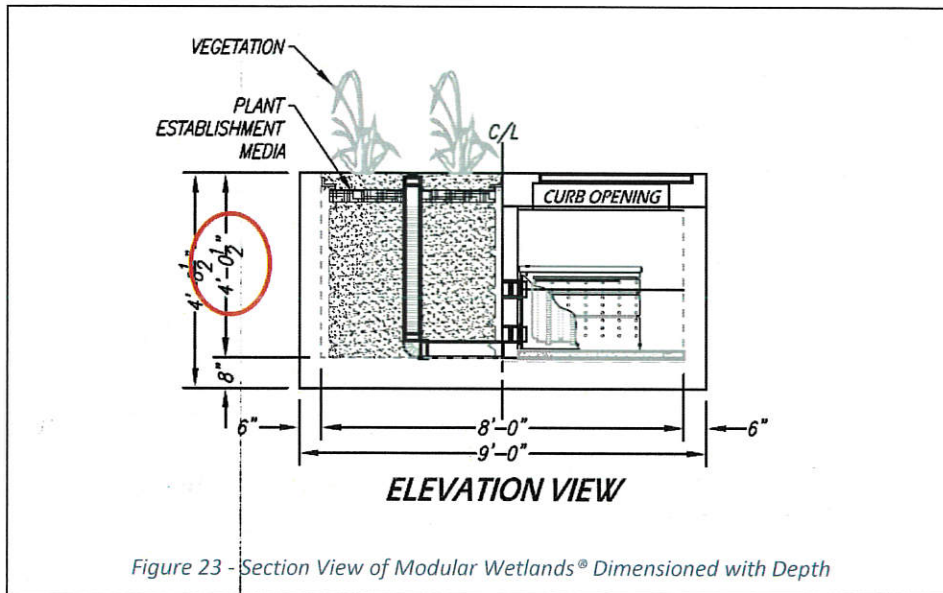

The Modular Wetlands® system also contains design features that prevent mosquito and vector breeding and access. The pre-treatment chamber and the discharge chamber are both available to be provided with a drain down feature. See Figure 22. Nuisance water that may be present in these chambers can drain down through a permeable floor thus eliminating even nuisance standing water in the Device.

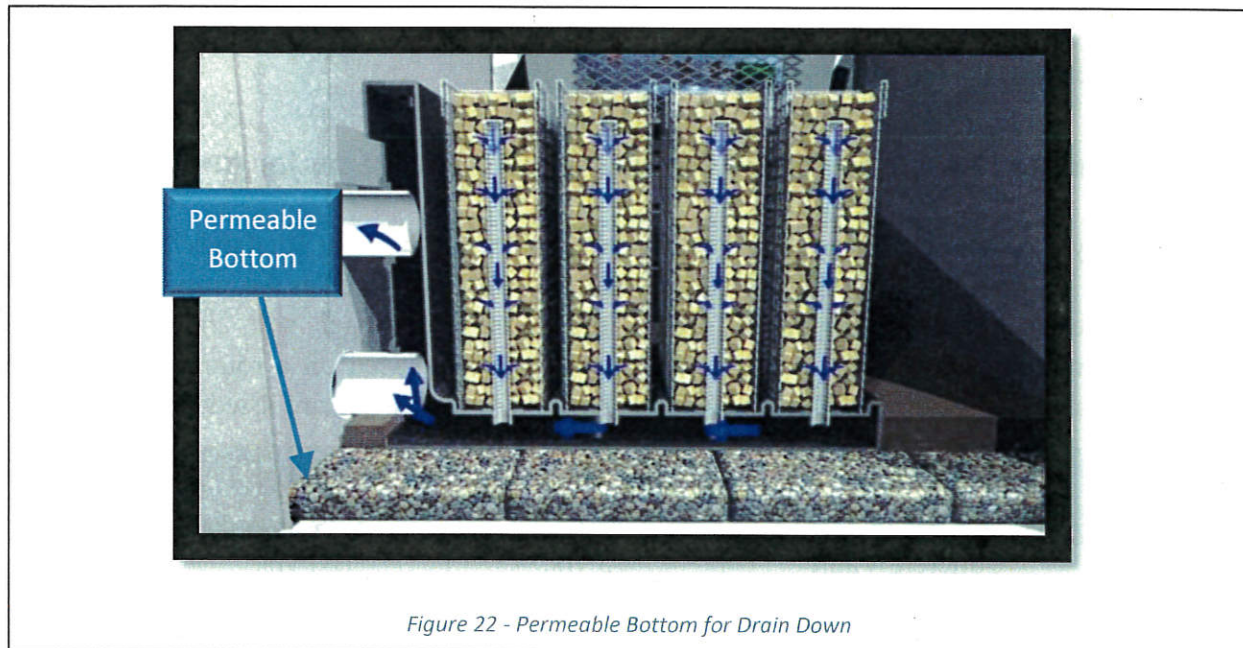

In addition, all manhole covers and access hatches are supplied with gasketed lids that seal the Modular Wetlands® system from mosquito and vector access. See Figure 24. Additionally, the manhole covers are designed with closed pick points. The pick point is a depression or hole in the cover for a tool to be inserted to help remove the cover. In many cases, the pick point is an open hole. For the Modular Wetlands® the pick point is a depressed slot that serves the same function

but does not allow an open hole and access into the vault. Mosquito and Vector are prevented from entering and escaping through the access points of the Modular Wetlands®.

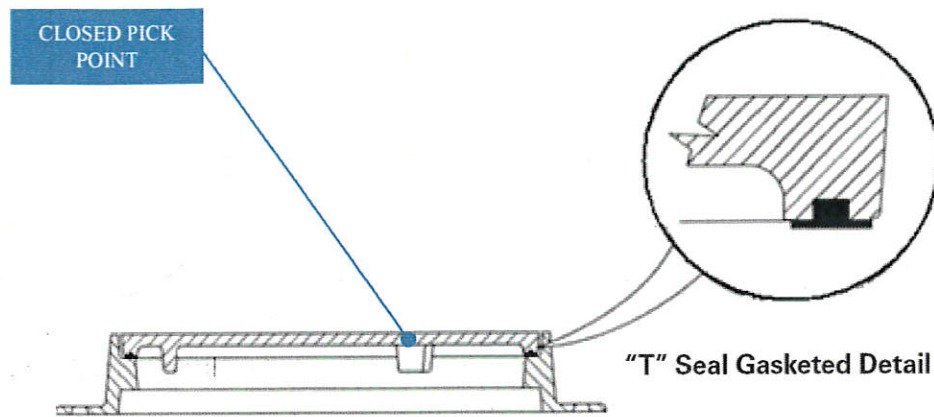

Figure 24 - Manhole Access Frame and Cover with Gasket and Sealed Pick Point

It should be noted that the Modular Wetlands® is available in configurations with curb inlet openings and grated inlet openings that directly connect to the pre-treatment chambers of the Modular Wetlands® system. These configurations leave the pre-treatment chamber open to the outside environment without the possibility for exclusion. As the design of the Modular Wetlands® system does not utilize a permanent pool of water, the exposed pre-treatment chamber is not expected to be problematic.

6.0 RELIABILITY INFORMATION

6.A. Estimated design life of Device components before major overhaul;

As previously noted in Section 3.J., the estimated design life for Modular Wetlands® system is 75 to 100 years. The design life is dependent on the materials utilized as well as the proper application of those materials. Certain components such as the media, media bags, soil, and plantings are consumable materials and are intended to be removed and replaced on a routine bases. The estimated design life for the major individual components of the Device are listed below

Component	Minimum Expected Life	Maximum Expected Life
Concrete Vault	75 yrs.	100 yrs.
Access Covers	75 yrs.	100 yrs.
Internal Components (plastic)	50 yrs.	75 yrs.
Internal Components (metal)	25 yrs.	50 yrs.
Pre-Treatment Media	6 mo.	2 yrs.
Biofiltration Media	10 yrs.	20 yrs.
Plantings	5 yrs.	10 yrs.

6.B. Device sensitivity to loadings other than trash (i.e., leaves, sediment, etc.);

The Modular Wetlands[®] is designed to treat a variety of pollutants including sediment, heavy metals, nutrients, and trash and debris. The presence of other pollutant loadings than trash have no effect on the trash capture performance of the Device. The Modular Wetlands[®] operates as a treatment train and the removal mechanisms are independent of one another. In addition, the Modular Wetlands[®] is designed to isolate large pollutants with tendencies to clog such as trash, leaves, and sediment. The presence of these pollutants in the pre-treatment chamber is evidence of the Device functioning correctly. Areas with higher than average volumes of leaves and sediment should be monitored and maintenance frequencies adjusted accordingly.

6.C. Warranty Information; and

Bio Clean provides a five year limited warranty for the Modular Wetlands[®] system per the conditions listed in the warranty document included in the application in Appendix E.

6.D. Customer support information.

Bio Clean[®] is a California based company and has three facilities to provide Customer Support within the State.

Bio Clean[®] Corporate Office
398 Via El Centro
Oceanside, CA 92058
Phone: (760) 433-7640
Office Fax: (760) 433-3176
info@BioCleanEnvironmental.com
Maintenance@BioCleanEnvironmental.com

7.0 FIELD/LAB TESTING INFORMATION AND ANALYSIS.

Bio Clean[®] has conducted numerous field and laboratory tests on the Modular Wetlands[®] system. None of these tests contained a technical component or requirement to monitor the removal of trash or specifically the capture of a 5mm particle or greater. However, the testing monitored for removal of fine and dissolved pollutants and the presence of trash in the effluent would be a cause for concern and potentially non-conformance to the test protocols. One of the most rigorous field monitoring studies conducted on the Modular Wetlands[®] system was the Washington Department of Ecology Field Monitoring Study Conforming to TAPE (Technology Assessment Protocol Ecology). This field monitoring study spanned a period of just over 13 months and included 28 separate sampled storm events. No evidence of trash or debris in the effluent was detected. A copy of the TER (Technical Evaluation Report) is included with this application in Appendix F.

Additionally, the Modular Wetlands® system includes a series of screens, the last in the series containing openings not greater than 3.175mm thereby negating the need for testing but also ensuring Full Capture of particles 5mm or greater.

APPENDIX A

SITE SPECIFIC DATA

PROJECT NUMBER	
PROJECT NAME	
PROJECT LOCATION	
STRUCTURE ID	
TREATMENT REQUIRED	FLOW BASED (CFS)
VOLUME BASED (CF)	
TREATMENT HGT. AVAILABLE (FT)	
PEAK BYPASS REQUIRED (CFS) - IF APPLICABLE	
PIPE DATA	I.E. MATERIAL DIAMETER
INLET PIPE 1	
INLET PIPE 2	
OUTLET PIPE	
RIM ELEVATION	PRETREATMENT BIOPILTRATION DISCHARGE
SURFACE LOAD	PARKWAY
FRAME & COVER	24" x 42" N/A
WETLAND MEDIA VOLUME (CY)	0.98
WETLAND MEDIA DELIVERY METHOD	TBD
ORIFICE SIZE (DIA. INCHES)	#1.03"
MAXIMUM PICK WEIGHT (LBS)	9108
NOTES:	

INSTALLATION NOTES

- CONTRACTOR TO PROVIDE ALL LABOR, EQUIPMENT, MATERIALS AND INCIDENTALS REQUIRED TO OFFLOAD AND INSTALL THE SYSTEM AND APPURTENANCES IN ACCORDANCE WITH THIS DRAWING AND THE MANUFACTURERS SPECIFICATIONS, UNLESS OTHERWISE STATED IN MANUFACTURERS CONTRACT.
- UNIT MUST BE INSTALLED ON LEVEL BASE. MANUFACTURER RECOMMENDS A MINIMUM 6" LEVEL ROCK BASE UNLESS SPECIFIED BY THE PROJECT ENGINEER. CONTRACTOR IS RESPONSIBLE TO VERIFY PROJECT ENGINEERS RECOMMENDED BASE SPECIFICATIONS.
- ALL PIPES MUST BE FLUSH WITH INSIDE SURFACE OF CONCRETE. (PIPES CANNOT INTRUDE BEYOND FLUSH). INVERT OF OUTFLOW PIPE MUST BE FLUSH WITH DISCHARGE CHAMBER FLOOR. ALL GAPS AROUND PIPES SHALL BE SEALED WATER TIGHT WITH A NON-SHRINK GROUT PER MANUFACTURERS STANDARD CONNECTION DETAIL AND SHALL MEET OR EXCEED REGIONAL PIPE CONNECTION STANDARDS.
- CONTRACTOR TO SUPPLY AND INSTALL ALL EXTERNAL CONNECTING PIPES.
- CONTRACTOR RESPONSIBLE FOR INSTALLATION OF ALL RISERS, MANHOLES, AND HATCHES. CONTRACTOR TO GROUT ALL MANHOLES AND HATCHES TO MATCH FINISHED SURFACE UNLESS SPECIFIED OTHERWISE.
- DRIP OR SPRAY IRRIGATION REQUIRED ON ALL UNITS WITH VEGETATION.

GENERAL NOTES

- MANUFACTURER TO PROVIDE ALL MATERIALS UNLESS OTHERWISE NOTED.
- ALL DIMENSIONS, ELEVATIONS, SPECIFICATIONS AND CAPACITIES ARE SUBJECT TO CHANGE. FOR PROJECT SPECIFIC DRAWINGS DETAILING EXACT DIMENSIONS, WEIGHTS AND ACCESSORIES PLEASE CONTACT MANUFACTURER.

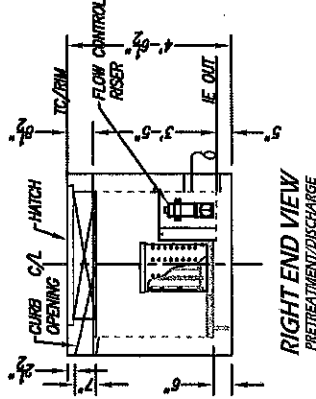
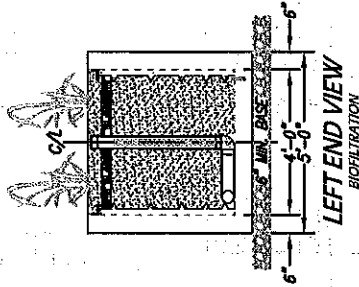
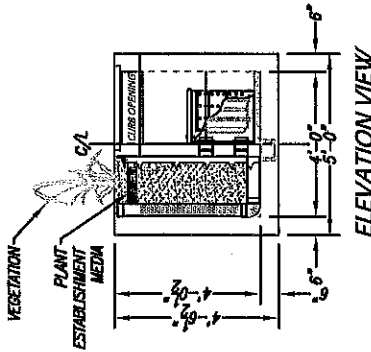
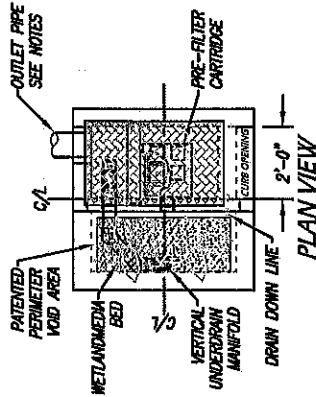

TREATMENT FLOW (CFS)	0.052
OPERATING HEAD (FT)	3.4
PRETREATMENT LOADING RATE (GPM/SF)	1.8
WETLAND MEDIA LOADING RATE (GPM/SF)	1.0

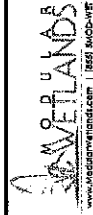

PROPRIETARY AND CONFIDENTIAL:
 THE INFORMATION CONTAINED IN THIS DRAWING IS THE SOLE PROPERTY OF MWSWETLANDS SYSTEMS. ANY REPRODUCTION IN PART OR AS A WHOLE WITHOUT THE WRITTEN PERMISSION OF MWSWETLANDS SYSTEMS IS PROHIBITED.

MWS-L-4-C
STORMWATER BIOPILTRATION SYSTEM
STANDARD DETAIL

SITE SPECIFIC DATA	
PROJECT NUMBER	
PROJECT NAME	
PROJECT LOCATION	
STRUCTURE ID	
TREATMENT REQUIRED	FLOW BASED (GFS)
VOLUME BASED (CF)	
TREATMENT HGL AVAILABLE (FT)	
PEAK BYPASS REQUIRED (GFS) - IF APPLICABLE	
PIPE DATA	I.E. MATERIAL DIAMETER
INLET PIPE 1	
INLET PIPE 2	
OUTLET PIPE	
PRETREATMENT	BIOFILTRATION DISCHARGE
RIM ELEVATION	
SURFACE LOAD	PARKWAY OPEN PLANTER
FRAME & COVER	24" x 42" N/A
WETLAND MEDIA VOLUME (CY)	0.98
WETLAND MEDIA DELIVERY METHOD	TBD
ORIFICE SIZE (DIA. INCHES)	#1.03"
MAXIMUM PICK WEIGHT (LBS)	9108
NOTES:	

INSTALLATION NOTES

- CONTRACTOR TO PROVIDE ALL LABOR, EQUIPMENT, MATERIALS AND INCIDENTALS REQUIRED TO OFFLOAD AND INSTALL THE SYSTEM AND APPURTENANCES IN ACCORDANCE WITH THIS DRAWING AND THE MANUFACTURERS SPECIFICATIONS, UNLESS OTHERWISE STATED IN MANUFACTURERS CONTRACT.
- UNIT MUST BE INSTALLED ON LEVEL BASE. MANUFACTURER RECOMMENDS A MINIMUM 6" LEVEL ROCK BASE UNLESS SPECIFIED BY THE PROJECT ENGINEER. CONTRACTOR IS RESPONSIBLE TO VERIFY PROJECT ENGINEERS RECOMMENDED BASE SPECIFICATIONS.
- ALL PIPES MUST BE FLUSH WITH INSIDE SURFACE OF CONCRETE. (PIPES CANNOT INTRUDE BEYOND FLUSH). INVERT OF OUTFLOW PIPE MUST BE FLUSH WITH DISCHARGE CHAMBER FLOOR. ALL GAPS AROUND PIPES SHALL BE SEALED WATER TIGHT WITH A NON-SHRINK GROUT PER MANUFACTURERS STANDARD CONNECTION DETAIL AND SHALL MEET OR EXCEED REGIONAL PIPE CONNECTION STANDARDS.
- CONTRACTOR TO SUPPLY AND INSTALL ALL EXTERNAL CONNECTING PIPES.
- CONTRACTOR RESPONSIBLE FOR INSTALLATION OF ALL RISERS, MANHOLES, AND HATCHES. CONTRACTOR TO GROUT ALL MANHOLES AND HATCHES TO MATCH FINISHED SURFACE UNLESS SPECIFIED OTHERWISE.
- DRIP OR SPRAY IRRIGATION REQUIRED ON ALL UNITS WITH VEGETATION.

GENERAL NOTES

- MANUFACTURER TO PROVIDE ALL MATERIALS UNLESS OTHERWISE NOTED.
- ALL DIMENSIONS, ELEVATIONS, SPECIFICATIONS AND CAPACITIES ARE SUBJECT TO CHANGE. FOR PROJECT SPECIFIC DRAWINGS DETAILING EXACT DIMENSIONS, WEIGHTS AND ACCESSORIES PLEASE CONTACT MANUFACTURER.

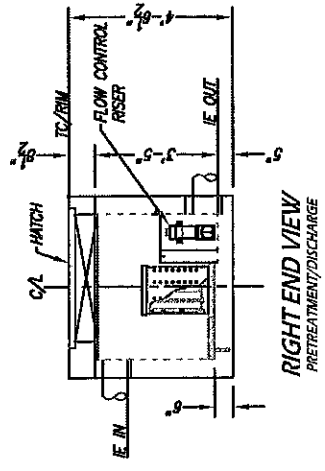
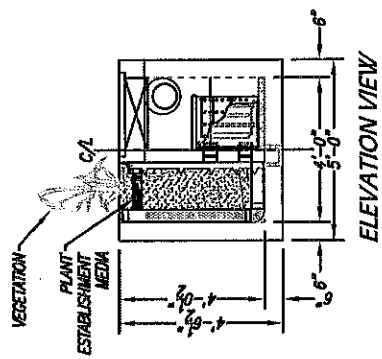
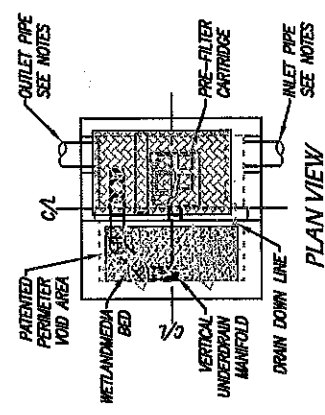
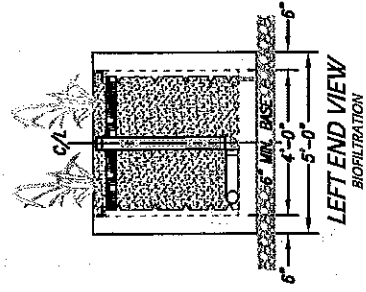

TREATMENT FLOW (GFS)	0.052
OPERATING HEAD (FT)	3.4
PRETREATMENT LOADING RATE (GPM/SF)	1.8
WETLAND MEDIA LOADING RATE (GPM/SF)	1.0

MWS-L-4-4-V
STORMWATER BIOFILTRATION SYSTEM
STANDARD DETAIL

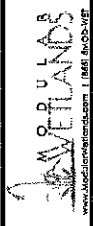

PROPRIETARY AND CONFIDENTIAL:
 THE INFORMATION CONTAINED IN THIS DRAWING IS THE SOLE PROPERTY OF WETLANDS SYSTEMS, INC. ANY REPRODUCTION OR TRANSMISSION OF THIS DRAWING WITHOUT THE WRITTEN PERMISSION OF WETLANDS SYSTEMS IS PROHIBITED.

SITE SPECIFIC DATA	
PROJECT NAME	
PROJECT LOCATION	
STRUCTURE ID	
TREATMENT REQUIRED	FLOW BASED (CFS)
VOLUME BASED (CF)	
TREATMENT HGL AVAILABLE (FT)	
PEAK BYPASS REQUIRED (CFS) - IF APPLICABLE	
PIPE DATA	I.E. MATERIAL DIAMETER
INLET PIPE 1	
INLET PIPE 2	
OUTLET PIPE	
RIM ELEVATION	PRETREATMENT BIOFILTRATION DISCHARGE
SURFACE LOAD	PARKWAY OPEN PLANTER
FRAME & COVER	30" X 36" N/A
WETLAND MEDIA VOLUME (CY)	1.48
WETLAND MEDIA DELIVERY METHOD	TBD
ORIFICE SIZE (DIA. INCHES)	#1.22"
MAXIMUM PICK WEIGHT (LBS)	TBD
NOTES:	

INSTALLATION NOTES

- CONTRACTOR TO PROVIDE ALL LABOR, EQUIPMENT, MATERIALS AND INCIDENTALS REQUIRED TO OFFLOAD, INSTALL THE SYSTEM AND APPURTENANCES IN ACCORDANCE WITH THIS DRAWING AND THE MANUFACTURERS SPECIFICATIONS, UNLESS OTHERWISE STATED IN MANUFACTURERS CONTRACT.
- UNIT MUST BE INSTALLED ON LEVEL BASE. MANUFACTURER RECOMMENDS A MINIMUM 6" LEVEL ROCK BASE UNLESS SPECIFIED BY THE PROJECT ENGINEER. CONTRACTOR IS RESPONSIBLE TO VERIFY PROJECT ENGINEERS RECOMMENDED BASE SPECIFICATIONS.
- ALL PIPES MUST BE FLUSH WITH INSIDE SURFACE OF CONCRETE. (PIPES CANNOT INTRUDE BEYOND FLUSH). INVERT OF OUTFLOW PIPE MUST BE FLUSH WITH DISCHARGE CHAMBER FLOOR. ALL GAPS AROUND PIPES SHALL BE SEALED WATER TIGHT WITH A NON-SHRINK GROUT PER MANUFACTURERS STANDARD CONNECTION DETAIL AND SHALL MEET OR EXCEED REGIONAL PIPE CONNECTION STANDARDS.
- CONTRACTOR TO SUPPLY AND INSTALL ALL EXTERNAL CONNECTING PIPES.
- CONTRACTOR RESPONSIBLE FOR INSTALLATION OF ALL RISERS, MANHOLES AND HATCHES. CONTRACTOR TO GROUT ALL MANHOLES AND HATCHES TO MATCH FINISHED SURFACE UNLESS SPECIFIED OTHERWISE.
- DRIP OR SPRAY IRRIGATION REQUIRED ON ALL UNITS WITH VEGETATION.

GENERAL NOTES

- MANUFACTURER TO PROVIDE ALL MATERIALS UNLESS OTHERWISE NOTED.
- ALL DIMENSIONS, ELEVATIONS, SPECIFICATIONS AND CAPACITIES ARE SUBJECT TO CHANGE. FOR PROJECT SPECIFIC DRAWINGS DETAILING EXACT DIMENSIONS, WEIGHTS AND ACCESSORIES PLEASE CONTACT MANUFACTURER.

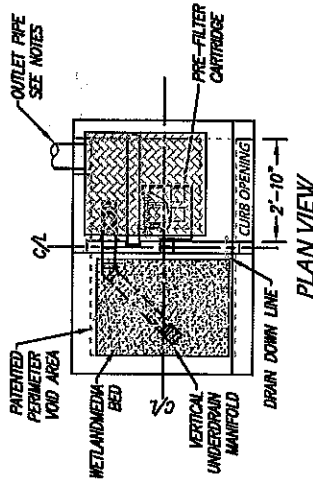

PLAN VIEW

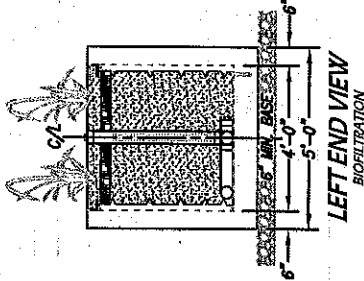

LEFT END VIEW
BIOFILTRATION

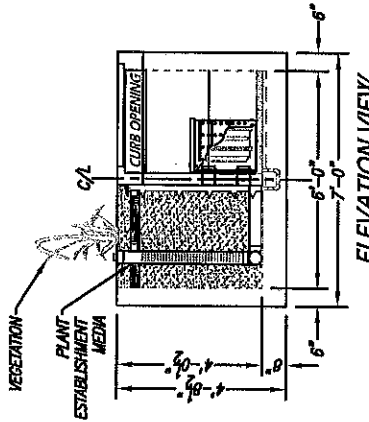

ELEVATION VIEW

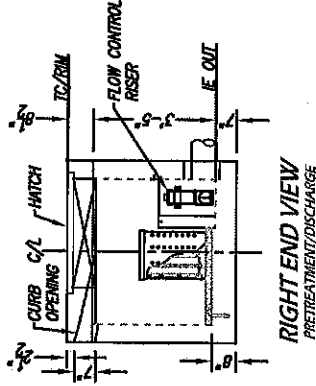

RIGHT END VIEW
PRETREATMENT/DISCHARGE

TREATMENT FLOW (CFS)	0.073
OPERATING HEAD (FT)	3.4
PRETREATMENT LOADING RATE (GPM/SF)	TBD
WETLAND MEDIA LOADING RATE (GPM/SF)	1.0

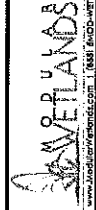

THE PRODUCT DESIGNER MAY BE REPRODUCED OR TRANSMITTED IN ANY FORM OR BY ANY MEANS, ELECTRONIC OR MECHANICAL, INCLUDING PHOTOCOPYING, RECORDING, OR BY ANY INFORMATION STORAGE AND RETRIEVAL SYSTEM, WITHOUT THE WRITTEN PERMISSION OF MODULAR WETLANDS SYSTEMS, INC. (MWS).
 7-08-2002 7:47:30Z 2/7/02
 3-REVISIONS, RELATED FOREIGN PATENTS OR OTHER PUBLISHED DOCUMENTS IS PROHIBITED.

PROPRIETARY AND CONFIDENTIAL:
 THE INFORMATION CONTAINED IN THIS DRAWING IS THE SOLE PROPERTY OF MODULAR WETLANDS SYSTEMS, INC. ANY REPRODUCTION IN WHOLE OR IN PART WITHOUT THE WRITTEN PERMISSION OF MODULAR WETLANDS SYSTEMS IS PROHIBITED.

GENERAL NOTES

- MANUFACTURER TO PROVIDE ALL MATERIALS UNLESS OTHERWISE NOTED.
- ALL DIMENSIONS, ELEVATIONS, SPECIFICATIONS AND CAPACITIES ARE SUBJECT TO CHANGE. FOR PROJECT SPECIFIC DRAWINGS DETAILING EXACT DIMENSIONS, WEIGHTS AND ACCESSORIES PLEASE CONTACT MANUFACTURER.

MWS-L-4-6-C
 STORMWATER BIOFILTRATION SYSTEM
 STANDARD DETAIL

SITE SPECIFIC DATA	
PROJECT NUMBER	
PROJECT NAME	
PROJECT LOCATION	
STRUCTURE ID	
TREATMENT REQUIRED	FLOW BASED (CFS)
VOLUME BASED (CF)	
TREATMENT HQL AVAILABLE (FT)	
PEAK BYPASS REQUIRED (CFS) - IF APPLICABLE	
PIPE DATA	I.E. MATERIAL DIAMETER
INLET PIPE 1	
INLET PIPE 2	
OUTLET PIPE	
PRETREATMENT	BIOFILTRATION DISCHARGE
RIM ELEVATION	
SURFACE LOAD	PARKWAY OPEN PLANTER
FRAME & COVER	30" x 36" N/A
WETLANDMEDIA VOLUME (CY)	1.68
WETLANDMEDIA DELIVERY METHOD	TBD
ORIFICE SIZE (DIA. INCHES)	#1.22"
MAXIMUM PICK WEIGHT (LBS)	12700
NOTES:	

INSTALLATION NOTES

- CONTRACTOR TO PROVIDE ALL LABOR, EQUIPMENT, MATERIALS AND INCIDENTALS REQUIRED TO OFFLOAD AND INSTALL THE SYSTEM AND APPURTENANCES IN ACCORDANCE WITH THIS DRAWING AND THE MANUFACTURERS SPECIFICATIONS, UNLESS OTHERWISE STATED IN MANUFACTURERS CONTRACT.
- UNIT MUST BE INSTALLED ON LEVEL BASE. MANUFACTURER RECOMMENDS A MINIMUM 6" LEVEL ROCK BASE UNLESS SPECIFIED BY THE PROJECT ENGINEER. CONTRACTOR IS RESPONSIBLE TO VERIFY PROJECT ENGINEERS RECOMMENDED BASE SPECIFICATIONS.
- ALL PIPES MUST BE FLUSH WITH INSIDE SURFACE OF CONCRETE. (PIPES CANNOT INTRUDE BEYOND FLUSH). INVERT OF OUTFLOW PIPE MUST BE FLUSH WITH DISCHARGE CHAMBER FLOOR. ALL GAPS AROUND PIPES SHALL BE SEALED WATER TIGHT WITH A NON-SHRINK GROUT PER MANUFACTURERS STANDARD CONNECTION DETAIL AND SHALL MEET OR EXCEED REGIONAL PIPE CONNECTION STANDARDS.
- CONTRACTOR TO SUPPLY AND INSTALL ALL EXTERNAL CONNECTING PIPES.
- CONTRACTOR RESPONSIBLE FOR INSTALLATION OF ALL RISERS, MANHOLES, AND HATCHES. CONTRACTOR TO GROUT ALL MANHOLES AND HATCHES TO MATCH FINISHED SURFACE UNLESS SPECIFIED OTHERWISE.
- DRIP OR SPRAY IRRIGATION REQUIRED ON ALL UNITS WITH VEGETATION.

GENERAL NOTES

- MANUFACTURER TO PROVIDE ALL MATERIALS UNLESS OTHERWISE NOTED.
- ALL DIMENSIONS, ELEVATIONS, SPECIFICATIONS AND CAPACITIES ARE SUBJECT TO CHANGE. FOR PROJECT SPECIFIC DRAWINGS DETAILING EXACT DIMENSIONS, WEIGHTS AND ACCESSORIES PLEASE CONTACT MANUFACTURER.

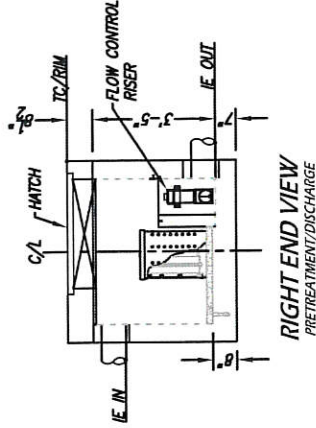
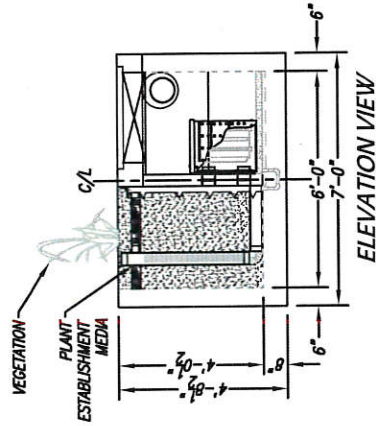
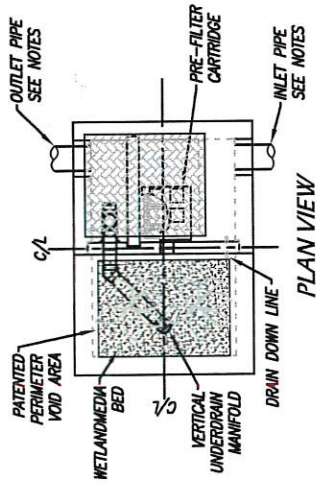
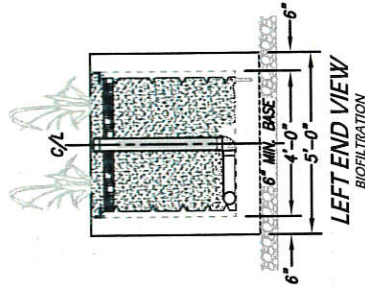

TREATMENT FLOW (CFS)	0.073
OPERATING HEAD (FT)	3.4
PRETREATMENT LOADING RATE (GPM/SF)	TBD
WETLAND MEDIA LOADING RATE (GPM/SF)	1.0

MWS-L-4-6-V
STORMWATER BIOFILTRATION SYSTEM
STANDARD DETAIL

MODULAR
WETLANDS
www.modularwetlands.com | 800.845.6400

PROPRIETARY AND CONFIDENTIAL:
THE INFORMATION CONTAINED IN THIS DRAWING IS THE SOLE PROPERTY OF MODULAR WETLANDS SYSTEMS. WITHOUT THE WRITTEN PERMISSION OF MODULAR WETLANDS SYSTEMS IS PROHIBITED.
THE PRODUCT DESCRIBED MAY BE PROTECTED BY ONE OR MORE OF THE FOLLOWING US PATENTS: 7,492,882; 7,470,882; 7,674,378; 7,674,379; 7,674,380; 7,674,381; 7,674,382; 7,674,383; 7,674,384; 7,674,385; 7,674,386; 7,674,387; 7,674,388; 7,674,389; 7,674,390; 7,674,391; 7,674,392; 7,674,393; 7,674,394; 7,674,395; 7,674,396; 7,674,397; 7,674,398; 7,674,399; 7,674,400; 7,674,401; 7,674,402; 7,674,403; 7,674,404; 7,674,405; 7,674,406; 7,674,407; 7,674,408; 7,674,409; 7,674,410; 7,674,411; 7,674,412; 7,674,413; 7,674,414; 7,674,415; 7,674,416; 7,674,417; 7,674,418; 7,674,419; 7,674,420; 7,674,421; 7,674,422; 7,674,423; 7,674,424; 7,674,425; 7,674,426; 7,674,427; 7,674,428; 7,674,429; 7,674,430; 7,674,431; 7,674,432; 7,674,433; 7,674,434; 7,674,435; 7,674,436; 7,674,437; 7,674,438; 7,674,439; 7,674,440; 7,674,441; 7,674,442; 7,674,443; 7,674,444; 7,674,445; 7,674,446; 7,674,447; 7,674,448; 7,674,449; 7,674,450; 7,674,451; 7,674,452; 7,674,453; 7,674,454; 7,674,455; 7,674,456; 7,674,457; 7,674,458; 7,674,459; 7,674,460; 7,674,461; 7,674,462; 7,674,463; 7,674,464; 7,674,465; 7,674,466; 7,674,467; 7,674,468; 7,674,469; 7,674,470; 7,674,471; 7,674,472; 7,674,473; 7,674,474; 7,674,475; 7,674,476; 7,674,477; 7,674,478; 7,674,479; 7,674,480; 7,674,481; 7,674,482; 7,674,483; 7,674,484; 7,674,485; 7,674,486; 7,674,487; 7,674,488; 7,674,489; 7,674,490; 7,674,491; 7,674,492; 7,674,493; 7,674,494; 7,674,495; 7,674,496; 7,674,497; 7,674,498; 7,674,499; 7,674,500; 7,674,501; 7,674,502; 7,674,503; 7,674,504; 7,674,505; 7,674,506; 7,674,507; 7,674,508; 7,674,509; 7,674,510; 7,674,511; 7,674,512; 7,674,513; 7,674,514; 7,674,515; 7,674,516; 7,674,517; 7,674,518; 7,674,519; 7,674,520; 7,674,521; 7,674,522; 7,674,523; 7,674,524; 7,674,525; 7,674,526; 7,674,527; 7,674,528; 7,674,529; 7,674,530; 7,674,531; 7,674,532; 7,674,533; 7,674,534; 7,674,535; 7,674,536; 7,674,537; 7,674,538; 7,674,539; 7,674,540; 7,674,541; 7,674,542; 7,674,543; 7,674,544; 7,674,545; 7,674,546; 7,674,547; 7,674,548; 7,674,549; 7,674,550; 7,674,551; 7,674,552; 7,674,553; 7,674,554; 7,674,555; 7,674,556; 7,674,557; 7,674,558; 7,674,559; 7,674,560; 7,674,561; 7,674,562; 7,674,563; 7,674,564; 7,674,565; 7,674,566; 7,674,567; 7,674,568; 7,674,569; 7,674,570; 7,674,571; 7,674,572; 7,674,573; 7,674,574; 7,674,575; 7,674,576; 7,674,577; 7,674,578; 7,674,579; 7,674,580; 7,674,581; 7,674,582; 7,674,583; 7,674,584; 7,674,585; 7,674,586; 7,674,587; 7,674,588; 7,674,589; 7,674,590; 7,674,591; 7,674,592; 7,674,593; 7,674,594; 7,674,595; 7,674,596; 7,674,597; 7,674,598; 7,674,599; 7,674,600; 7,674,601; 7,674,602; 7,674,603; 7,674,604; 7,674,605; 7,674,606; 7,674,607; 7,674,608; 7,674,609; 7,674,610; 7,674,611; 7,674,612; 7,674,613; 7,674,614; 7,674,615; 7,674,616; 7,674,617; 7,674,618; 7,674,619; 7,674,620; 7,674,621; 7,674,622; 7,674,623; 7,674,624; 7,674,625; 7,674,626; 7,674,627; 7,674,628; 7,674,629; 7,674,630; 7,674,631; 7,674,632; 7,674,633; 7,674,634; 7,674,635; 7,674,636; 7,674,637; 7,674,638; 7,674,639; 7,674,640; 7,674,641; 7,674,642; 7,674,643; 7,674,644; 7,674,645; 7,674,646; 7,674,647; 7,674,648; 7,674,649; 7,674,650; 7,674,651; 7,674,652; 7,674,653; 7,674,654; 7,674,655; 7,674,656; 7,674,657; 7,674,658; 7,674,659; 7,674,660; 7,674,661; 7,674,662; 7,674,663; 7,674,664; 7,674,665; 7,674,666; 7,674,667; 7,674,668; 7,674,669; 7,674,670; 7,674,671; 7,674,672; 7,674,673; 7,674,674; 7,674,675; 7,674,676; 7,674,677; 7,674,678; 7,674,679; 7,674,680; 7,674,681; 7,674,682; 7,674,683; 7,674,684; 7,674,685; 7,674,686; 7,674,687; 7,674,688; 7,674,689; 7,674,690; 7,674,691; 7,674,692; 7,674,693; 7,674,694; 7,674,695; 7,674,696; 7,674,697; 7,674,698; 7,674,699; 7,674,700; 7,674,701; 7,674,702; 7,674,703; 7,674,704; 7,674,705; 7,674,706; 7,674,707; 7,674,708; 7,674,709; 7,674,710; 7,674,711; 7,674,712; 7,674,713; 7,674,714; 7,674,715; 7,674,716; 7,674,717; 7,674,718; 7,674,719; 7,674,720; 7,674,721; 7,674,722; 7,674,723; 7,674,724; 7,674,725; 7,674,726; 7,674,727; 7,674,728; 7,674,729; 7,674,730; 7,674,731; 7,674,732; 7,674,733; 7,674,734; 7,674,735; 7,674,736; 7,674,737; 7,674,738; 7,674,739; 7,674,740; 7,674,741; 7,674,742; 7,674,743; 7,674,744; 7,674,745; 7,674,746; 7,674,747; 7,674,748; 7,674,749; 7,674,750; 7,674,751; 7,674,752; 7,674,753; 7,674,754; 7,674,755; 7,674,756; 7,674,757; 7,674,758; 7,674,759; 7,674,760; 7,674,761; 7,674,762; 7,674,763; 7,674,764; 7,674,765; 7,674,766; 7,674,767; 7,674,768; 7,674,769; 7,674,770; 7,674,771; 7,674,772; 7,674,773; 7,674,774; 7,674,775; 7,674,776; 7,674,777; 7,674,778; 7,674,779; 7,674,780; 7,674,781; 7,674,782; 7,674,783; 7,674,784; 7,674,785; 7,674,786; 7,674,787; 7,674,788; 7,674,789; 7,674,790; 7,674,791; 7,674,792; 7,674,793; 7,674,794; 7,674,795; 7,674,796; 7,674,797; 7,674,798; 7,674,799; 7,674,800; 7,674,801; 7,674,802; 7,674,803; 7,674,804; 7,674,805; 7,674,806; 7,674,807; 7,674,808; 7,674,809; 7,674,810; 7,674,811; 7,674,812; 7,674,813; 7,674,814; 7,674,815; 7,674,816; 7,674,817; 7,674,818; 7,674,819; 7,674,820; 7,674,821; 7,674,822; 7,674,823; 7,674,824; 7,674,825; 7,674,826; 7,674,827; 7,674,828; 7,674,829; 7,674,830; 7,674,831; 7,674,832; 7,674,833; 7,674,834; 7,674,835; 7,674,836; 7,674,837; 7,674,838; 7,674,839; 7,674,840; 7,674,841; 7,674,842; 7,674,843; 7,674,844; 7,674,845; 7,674,846; 7,674,847; 7,674,848; 7,674,849; 7,674,850; 7,674,851; 7,674,852; 7,674,853; 7,674,854; 7,674,855; 7,674,856; 7,674,857; 7,674,858; 7,674,859; 7,674,860; 7,674,861; 7,674,862; 7,674,863; 7,674,864; 7,674,865; 7,674,866; 7,674,867; 7,674,868; 7,674,869; 7,674,870; 7,674,871; 7,674,872; 7,674,873; 7,674,874; 7,674,875; 7,674,876; 7,674,877; 7,674,878; 7,674,879; 7,674,880; 7,674,881; 7,674,882; 7,674,883; 7,674,884; 7,674,885; 7,674,886; 7,674,887; 7,674,888; 7,674,889; 7,674,890; 7,674,891; 7,674,892; 7,674,893; 7,674,894; 7,674,895; 7,674,896; 7,674,897; 7,674,898; 7,674,899; 7,674,900; 7,674,901; 7,674,902; 7,674,903; 7,674,904; 7,674,905; 7,674,906; 7,674,907; 7,674,908; 7,674,909; 7,674,910; 7,674,911; 7,674,912; 7,674,913; 7,674,914; 7,674,915; 7,674,916; 7,674,917; 7,674,918; 7,674,919; 7,674,920; 7,674,921; 7,674,922; 7,674,923; 7,674,924; 7,674,925; 7,674,926; 7,674,927; 7,674,928; 7,674,929; 7,674,930; 7,674,931; 7,674,932; 7,674,933; 7,674,934; 7,674,935; 7,674,936; 7,674,937; 7,674,938; 7,674,939; 7,674,940; 7,674,941; 7,674,942; 7,674,943; 7,674,944; 7,674,945; 7,674,946; 7,674,947; 7,674,948; 7,674,949; 7,674,950; 7,674,951; 7,674,952; 7,674,953; 7,674,954; 7,674,955; 7,674,956; 7,674,957; 7,674,958; 7,674,959; 7,674,960; 7,674,961; 7,674,962; 7,674,963; 7,674,964; 7,674,965; 7,674,966; 7,674,967; 7,674,968; 7,674,969; 7,674,970; 7,674,971; 7,674,972; 7,674,973; 7,674,974; 7,674,975; 7,674,976; 7,674,977; 7,674,978; 7,674,979; 7,674,980; 7,674,981; 7,674,982; 7,674,983; 7,674,984; 7,674,985; 7,674,986; 7,674,987; 7,674,988; 7,674,989; 7,674,990; 7,674,991; 7,674,992; 7,674,993; 7,674,994; 7,674,995; 7,674,996; 7,674,997; 7,674,998; 7,674,999; 7,675,000.

SITE SPECIFIC DATA	
PROJECT NUMBER	
PROJECT NAME	
PROJECT LOCATION	
STRUCTURE ID	
TREATMENT REQUIRED	FLOW BASED (CFS)
VOLUME BASED (CF)	
TREATMENT HGL AVAILABLE (FT)	
PEAK BYPASS REQUIRED (CFS) - IF APPLICABLE	
PIPE DATA	I.E. MATERIAL DIAMETER
INLET PIPE 1	
INLET PIPE 2	
OUTLET PIPE	
PRETREATMENT	BIOFILTRATION DISCHARGE
RIM ELEVATION	
SURFACE LOAD	PARKWAY OPEN PLANTER
FRAME & COVER	36" x 36" N/A N/A
WETLANDMEDIA VOLUME (CY)	1.68
WETLANDMEDIA DELIVERY METHOD	TBD
ORIFICE SIZE (DIA. INCHES)	#1.22"
MAXIMUM PICK WEIGHT (LBS)	13200
NOTES:	

INSTALLATION NOTES

- CONTRACTOR TO PROVIDE ALL LABOR, EQUIPMENT, MATERIALS AND INCIDENTALS REQUIRED TO OFFLOAD AND INSTALL THE SYSTEM AND APPURTENANCES IN ACCORDANCE WITH THIS DRAWING AND THE MANUFACTURERS SPECIFICATIONS, UNLESS OTHERWISE STATED IN MANUFACTURERS CONTRACT.
- UNIT MUST BE INSTALLED ON LEVEL BASE. MANUFACTURER RECOMMENDS A MINIMUM 6" LEVEL ROCK BASE UNLESS SPECIFIED BY THE PROJECT ENGINEER. CONTRACTOR IS RESPONSIBLE TO VERIFY PROJECT ENGINEERS RECOMMENDED BASE SPECIFICATIONS.
- ALL PIPES MUST BE FLUSH WITH INSIDE SURFACE OF CONCRETE (PIPES CANNOT INTRUDE BEYOND FLUSH). INVERT OF OUTFLOW PIPE MUST BE FLUSH WITH DISCHARGE CHAMBER FLOOR. ALL GAPS AROUND PIPES SHALL BE SEALED WATER TIGHT WITH A NON-SHRINK GROUT PER MANUFACTURERS STANDARD CONNECTION DETAIL AND SHALL MEET OR EXCEED REGIONAL PIPE CONNECTION STANDARDS.
- CONTRACTOR TO SUPPLY AND INSTALL ALL EXTERNAL CONNECTING PIPES.
- CONTRACTOR RESPONSIBLE FOR INSTALLATION OF ALL RISERS, MANHOLES, AND HATCHES. CONTRACTOR TO GROUT ALL MANHOLES AND HATCHES TO MATCH FINISHED SURFACE UNLESS SPECIFIED OTHERWISE.
- DRIP OR SPRAY IRRIGATION REQUIRED ON ALL UNITS WITH VEGETATION.

GENERAL NOTES

- MANUFACTURER TO PROVIDE ALL MATERIALS UNLESS OTHERWISE NOTED.
- ALL DIMENSIONS, ELEVATIONS, SPECIFICATIONS AND CAPACITIES ARE SUBJECT TO CHANGE FOR PROJECT SPECIFIC DRAWINGS DETAILING EXACT DIMENSIONS, WEIGHTS AND ACCESSORIES PLEASE CONTACT MANUFACTURER.

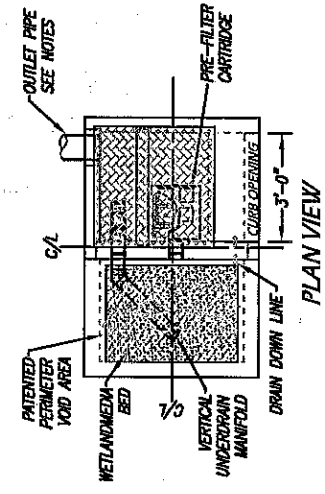

PLAN VIEW

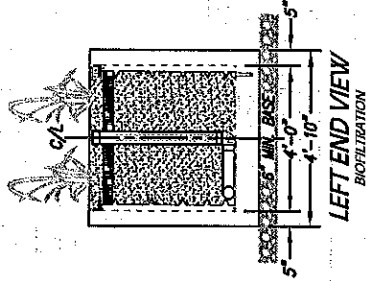

LEFT END VIEW
BIOFILTRATION

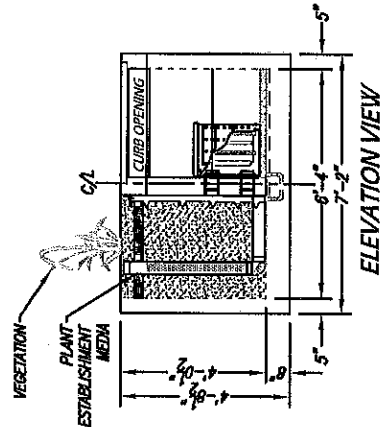

ELEVATION VIEW

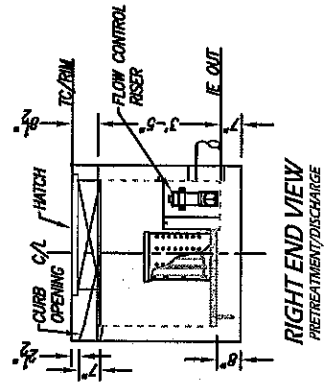

RIGHT END VIEW
PRETREATMENT/DISCHARGE

TREATMENT FLOW (CFS)	0.073
OPERATING HEAD (FT)	3.4
PRETREATMENT LOADING RATE (GPM/SF)	TBD
WETLAND MEDIA LOADING RATE (GPM/SF)	1.0

MWS-L-4-6.33-C
STORMWATER BIOFILTRATION SYSTEM
STANDARD DETAIL

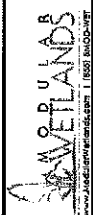

PROPRIETARY AND CONFIDENTIAL
THE INFORMATION CONTAINED IN THIS DRAWING IS THE SOLE PROPERTY OF THE DESIGNER. NO PART OF THIS DRAWING OR REPRODUCTION IN ANY FORM OR BY ANY MEANS WITHOUT THE WRITTEN PERMISSION OF THE DESIGNER IS TO BE REPRODUCED OR TRANSMITTED IN ANY FORM OR BY ANY MEANS.

SITE SPECIFIC DATA	
PROJECT NUMBER	
PROJECT NAME	
PROJECT LOCATION	
STRUCTURE ID	
TREATMENT REQUIRED	FLOW BASED (GFS)
VOLUME BASED (CF)	
TREATMENT HGL AVAILABLE (FT)	
PEAK BYPASS REQUIRED (GFS) - IF APPLICABLE	
PIPE DATA	I.E. MATERIAL DIAMETER
INLET PIPE 1	
INLET PIPE 2	
OUTLET PIPE	
PRETREATMENT	BIOFILTRATION DISCHARGE
RIM ELEVATION	
SURFACE LOAD	PARKWAY OPEN PLANTER
FRAME & COVER	36" x 36" N/A
WETLANDMEDIA VOLUME (CY)	1.68
WETLANDMEDIA DELIVERY METHOD	TBD
ORIFICE SIZE (DIA. INCHES)	#1.22"
MAXIMUM PICK WEIGHT (LBS)	13200
NOTES:	

INSTALLATION NOTES

- CONTRACTOR TO PROVIDE ALL LABOR, EQUIPMENT, MATERIALS AND INCIDENTALS REQUIRED TO OUTFLOW AND INSTALL THE SYSTEM AND APPURTENANCES IN ACCORDANCE WITH THIS DRAWING AND THE MANUFACTURERS SPECIFICATIONS, UNLESS OTHERWISE STATED IN MANUFACTURERS CONTRACT.
- UNIT MUST BE INSTALLED ON LEVEL BASE. MANUFACTURER RECOMMENDS A MINIMUM 6" LEVEL ROCK BASE UNLESS SPECIFIED BY THE PROJECT ENGINEER. CONTRACTOR IS RESPONSIBLE TO VERIFY PROJECT ENGINEERS RECOMMENDED BASE SPECIFICATIONS.
- ALL PIPES MUST BE FLUSH WITH INSIDE SURFACE OF CONCRETE. (PIPES CANNOT INTRUDE BEYOND FLUSH). INVERT OF OUTFLOW PIPE MUST BE FLUSH WITH DISCHARGE CHAMBER FLOOR. ALL GAPS AROUND PIPES SHALL BE SEALED WATER TIGHT WITH A NON-SHRINK GROUT PER MANUFACTURERS STANDARD CONNECTION DETAIL AND SHALL MEET OR EXCEED REGIONAL PIPE CONNECTION STANDARDS.
- CONTRACTOR TO SUPPLY AND INSTALL ALL EXTERNAL CONNECTING PIPES.
- CONTRACTOR RESPONSIBLE FOR INSTALLATION OF ALL RISERS, MANHOLES, AND HATCHES. CONTRACTOR TO GROUT ALL MANHOLES AND HATCHES TO MATCH FINISHED SURFACE UNLESS SPECIFIED OTHERWISE.
- DRIP OR SPRAY IRRIGATION REQUIRED ON ALL UNITS WITH VEGETATION.

GENERAL NOTES

- MANUFACTURER TO PROVIDE ALL MATERIALS UNLESS OTHERWISE NOTED.
- ALL DIMENSIONS, ELEVATIONS, SPECIFICATIONS AND CAPACITIES ARE SUBJECT TO CHANGE. FOR PROJECT SPECIFIC DRAWINGS DETAILING EXACT DIMENSIONS, WEIGHTS AND ACCESSORIES PLEASE CONTACT MANUFACTURER.

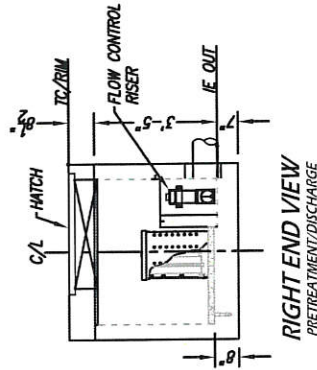
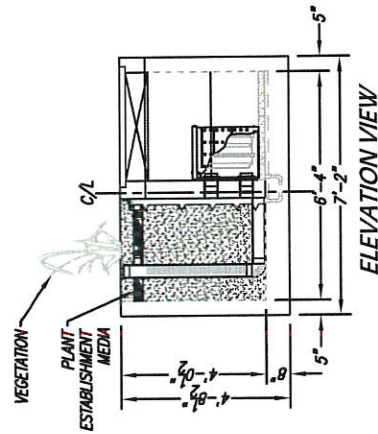
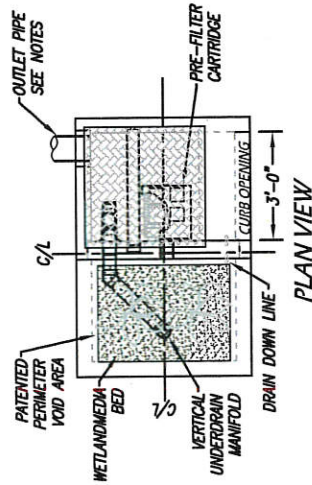
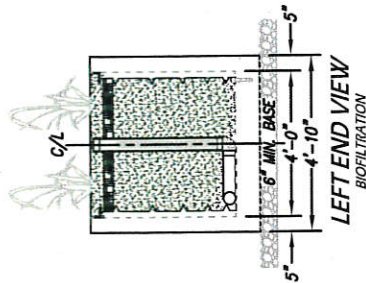

TREATMENT FLOW (GFS)	0.073
OPERATING HEAD (FT)	3.4
PRETREATMENT LOADING RATE (GPM/SF)	TBD
WETLAND MEDIA LOADING RATE (GPM/SF)	1.0

MWS-L-4-6.33-V
STORMWATER BIOFILTRATION SYSTEM
STANDARD DETAIL



PROPRIETARY AND CONFIDENTIAL:
 THE INFORMATION CONTAINED IN THIS DRAWING IS THE SOLE PROPERTY OF MODULAR WETLANDS SYSTEMS. ANY REPRODUCTION OR TRANSMISSION OF THIS DRAWING WITHOUT THE WRITTEN PERMISSION OF MODULAR WETLANDS SYSTEMS IS PROHIBITED.

THE PRODUCT DESCRIBED MAY BE PROTECTED BY ONE OR MORE OF THE FOLLOWING US PATENTS: 7,452,362; 7,471,862; 7,674,376; 8,011,411. ALL RIGHTS RESERVED. PATENTS OR OTHER RIGHTS PENDING.

SITE SPECIFIC DATA			
PROJECT NUMBER			
PROJECT NAME			
PROJECT LOCATION			
STRUCTURE ID			
TREATMENT REQUIRED	FLOW BASED (CFS)		
VOLUME BASED (CFT)			
TREATMENT HGL AVAILABLE (FT)			
PEAK BYPASS REQUIRED (CFS) - IF APPLICABLE			
PIPE DATA	MATERIAL	DIAMETER	
INLET PIPE 1			
INLET PIPE 2			
OUTLET PIPE			
RIM ELEVATION	PRETREATMENT	BIOFILTRATION	DISCHARGE
SURFACE LOAD	PARKWAY	OPEN PLANTER	PARKWAY
FRAME & COVER	36" x 36"	N/A	N/A
WETLANDMEDIA VOLUME (CY)			1.68
WETLANDMEDIA DELIVERY METHOD			TBD
ORFICE SIZE (DIA. INCHES)			#1.25"
MAXIMUM PICK WEIGHT (LBS)			13200
NOTES:			

INSTALLATION NOTES

- CONTRACTOR TO PROVIDE ALL LABOR, EQUIPMENT, MATERIALS AND INCIDENTALS REQUIRED TO OFFLOAD AND INSTALL THE SYSTEM AND APPURTENANCES IN ACCORDANCE WITH THIS DRAWING AND THE MANUFACTURERS SPECIFICATIONS, UNLESS OTHERWISE STATED IN MANUFACTURERS CONTRACT.
- UNIT MUST BE INSTALLED ON LEVEL BASE. MANUFACTURER RECOMMENDS A MINIMUM 6" LEVEL ROCK BASE UNLESS SPECIFIED BY THE PROJECT ENGINEER. CONTRACTOR IS RESPONSIBLE TO VERIFY PROJECT ENGINEERS RECOMMENDED BASE SPECIFICATIONS.
- ALL PIPES MUST BE FLUSH WITH INSIDE SURFACE OF CONCRETE. (PIPES CANNOT INTERLUDE BEYOND FLUSH). INVERT OF OUTFLOW PIPE MUST BE FLUSH WITH DISCHARGE CHAMBER FLOOR. ALL GAPS AROUND PIPES SHALL BE SEALED WATER TIGHT WITH A NON-SHRINK GROUT PER MANUFACTURERS STANDARD CONNECTION DETAIL AND SHALL MEET OR EXCEED REGIONAL PIPE CONNECTION STANDARDS.
- CONTRACTOR TO SUPPLY AND INSTALL ALL EXTERNAL CONNECTING PIPES.
- CONTRACTOR RESPONSIBLE FOR INSTALLATION OF ALL RISERS, MANHOLES, AND HATCHES. CONTRACTOR TO GROUT ALL MANHOLES AND HATCHES TO MATCH FINISHED SURFACE UNLESS SPECIFIED OTHERWISE.
- DRIP OR SPRAY IRRIGATION REQUIRED ON ALL UNITS WITH VEGETATION.

GENERAL NOTES

- MANUFACTURER TO PROVIDE ALL MATERIALS UNLESS OTHERWISE NOTED.
- ALL DIMENSIONS, ELEVATIONS, SPECIFICATIONS AND CAPACITIES ARE SUBJECT TO CHANGE. FOR PRODUCT SPECIFIC DRAWINGS DETAILING EXACT DIMENSIONS, WEIGHTS AND ACCESSORIES PLEASE CONTACT MANUFACTURER.

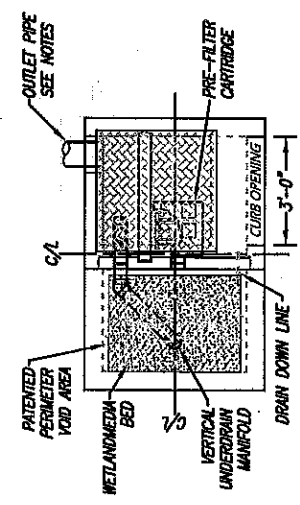

PLAN VIEW

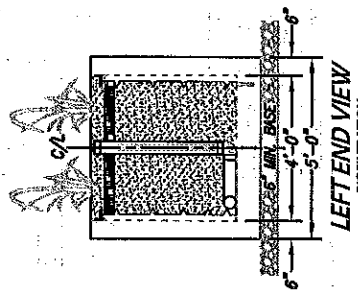

LEFT END VIEW
BIOFILTRATION

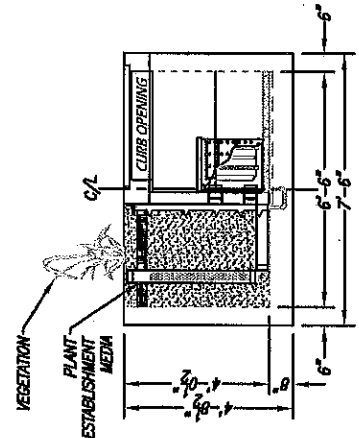

ELEVATION VIEW

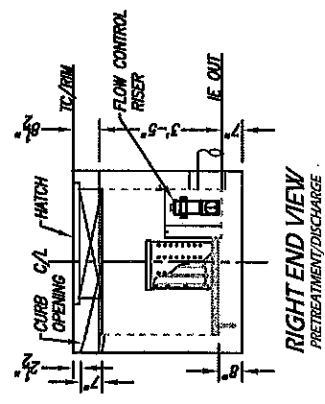

RIGHT END VIEW
PRETREATMENT/DISCHARGE

TREATMENT FLOW (CFS)	0.073
OPERATING HEAD (FT)	3.4
PRETREATMENT LOADING RATE (GPM/SF)	TBD
WETLAND MEDIA LOADING RATE (GPM/SF)	1.0

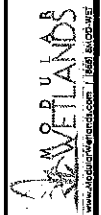

PROPRIETARY AND CONFIDENTIAL:
THE INFORMATION CONTAINED IN THIS DRAWING IS THE SOLE PROPERTY OF WETLANDS INCORPORATED. ANY REPRODUCTION OR TRANSMISSION OF THIS DRAWING WITHOUT THE WRITTEN PERMISSION OF WETLANDS INCORPORATED IS PROHIBITED.

MWS-L-4-6.5-C
STORMWATER BIOFILTRATION SYSTEM
STANDARD DETAIL

SITE SPECIFIC DATA	
PROJECT NUMBER	
PROJECT NAME	
PROJECT LOCATION	
STRUCTURE ID	
TREATMENT REQUIRED	FLOW BASED (CFS)
VOLUME BASED (CF)	
TREATMENT HGL AVAILABLE (FT)	
PEAK BYPASS REQUIRED (CFS) - IF APPLICABLE	
PIPE DATA	IE MATERIAL DIAMETER
INLET PIPE 1	
INLET PIPE 2	
OUTLET PIPE	
PRETREATMENT	BIOFILTRATION DISCHARGE
RIM ELEVATION	
SURFACE LOAD	PARKWAY OPEN PLANTER PARKWAY
FRAME & COVER	36" x 36" N/A
WETLAND MEDIA VOLUME (CY)	N/A
WETLAND MEDIA DELIVERY METHOD	TBD
ORIFICE SIZE (DIA. INCHES)	#1.22"
MAXIMUM PICK WEIGHT (LBS)	13200
NOTES:	

INSTALLATION NOTES

- CONTRACTOR TO PROVIDE ALL LABOR, EQUIPMENT, MATERIALS AND INCIDENTALS REQUIRED TO OUTFLOW AND INSTALL THE SYSTEM AND ADJUSTMENTS IN ACCORDANCE WITH THIS DRAWING AND THE MANUFACTURER'S SPECIFICATIONS, UNLESS OTHERWISE STATED IN MANUFACTURER'S CONTRACT.
- UNIT MUST BE INSTALLED ON LEVEL BASE. MANUFACTURER RECOMMENDS A MINIMUM 6" LEVEL ROCK BASE UNLESS SPECIFIED BY THE PROJECT ENGINEER. CONTRACTOR IS RESPONSIBLE TO VERIFY PROJECT ENGINEER'S RECOMMENDED BASE SPECIFICATIONS.
- ALL PIPES MUST BE FLUSH WITH INSIDE SURFACE OF CONCRETE. (PIPES CANNOT INTRUDE BEYOND FLUSH). INVERT OF OUTFLOW PIPE MUST BE FLUSH WITH DISCHARGE CHAMBER FLOOR. ALL GAPS AROUND PIPES SHALL BE SEALED WATER TIGHT WITH A NON-SHRINK GROUT PER MANUFACTURER'S STANDARD CONNECTION DETAIL AND SHALL MEET OR EXCEED REGIONAL PIPE CONNECTION STANDARDS.
- CONTRACTOR TO SUPPLY AND INSTALL ALL EXTERNAL CONNECTING PIPES.
- CONTRACTOR RESPONSIBLE FOR INSTALLATION OF ALL RISERS, MANHOLES, AND HATCHES. CONTRACTOR TO GROUT ALL MANHOLES AND HATCHES TO MATCH FINISHED SURFACE UNLESS SPECIFIED OTHERWISE.
- DRIP OR SPRAY IRRIGATION REQUIRED ON ALL UNITS WITH VEGETATION.

GENERAL NOTES

- MANUFACTURER TO PROVIDE ALL MATERIALS UNLESS OTHERWISE NOTED.
- ALL DIMENSIONS, ELEVATIONS, SPECIFICATIONS AND CAPACITIES ARE SUBJECT TO CHANGE. FOR PROJECT SPECIFIC DRAWINGS DETAILING EXACT DIMENSIONS, WEIGHTS AND ACCESSORIES PLEASE CONTACT MANUFACTURER.

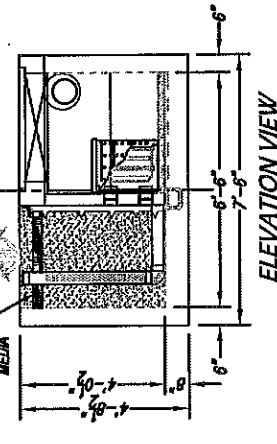
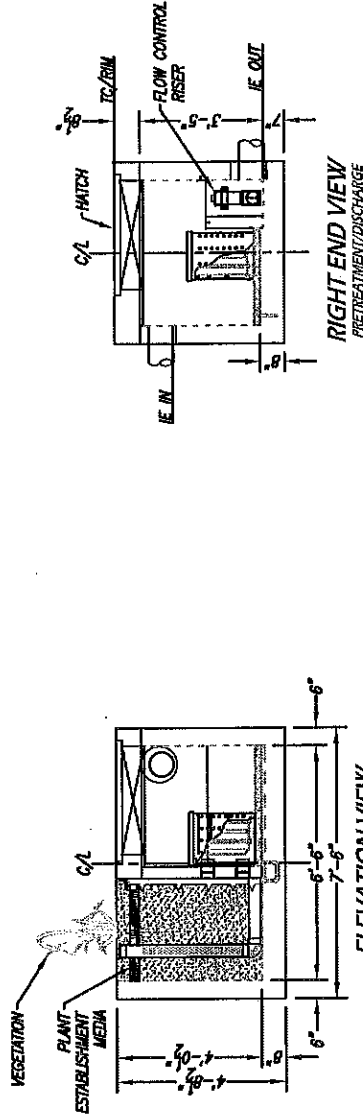
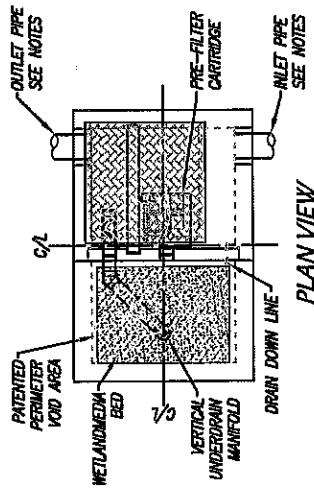
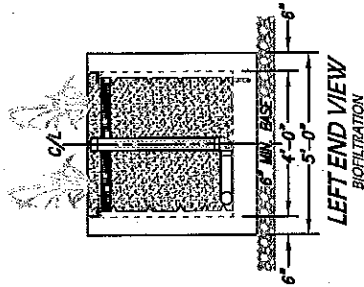

TREATMENT FLOW (CFS)	0.073
OPERATING HEAD (FT)	3.4
PRETREATMENT LOADING RATE (GPM/SF)	TBD
WETLAND MEDIA LOADING RATE (GPM/SF)	1.0

MWS-L-4-6.5-V
STORMWATER BIOFILTRATION SYSTEM
STANDARD DETAIL



PROPRIETARY AND CONFIDENTIAL
THE INFORMATION CONTAINED IN THIS DRAWING IS THE SOLE PROPERTY OF MARSH WETLANDS SYSTEMS, INC. REPRODUCTION IN PART OR AS A WHOLE WITHOUT THE WRITTEN PERMISSION OF MARSH WETLANDS SYSTEMS IS PROHIBITED.

THE PRODUCT DESCRIBED MAY BE THE PROPERTY OF MARSH WETLANDS SYSTEMS, INC. OR OTHER PATENTING FIRMS OR OTHER PATENTING FIRMS.

SITE SPECIFIC DATA	
PROJECT NUMBER	
PROJECT NAME	
PROJECT LOCATION	
STRUCTURE ID	
TREATMENT REQUIRED	FLOW BASED (GFS)
VOLUME BASED (CF)	
TREATMENT HGL AVAILABLE (FT)	
PEAK BYPASS REQUIRED (GFS) - IF APPLICABLE	
PIPE DATA	I.E. MATERIAL DIAMETER
INLET PIPE 1	
INLET PIPE 2	
OUTLET PIPE	
RIM ELEVATION	PRETREATMENT BIOFILTRATION DISCHARGE
SURFACE LOAD	PARKWAY
FRAME & COVER	36" x 36" N/A
WETLANDMEDIA VOLUME (CY)	N/A
WETLANDMEDIA DELIVERY METHOD	2.37
ORIFICE SIZE (DIA. INCHES)	TBD
MAXIMUM PICK WEIGHT (LBS)	#1.22"
NOTES:	18500

INSTALLATION NOTES

- CONTRACTOR TO PROVIDE ALL LABOR, EQUIPMENT, MATERIALS AND INCIDENTALS REQUIRED TO OFFLOAD AND INSTALL THE SYSTEM AND APPURTENANCES IN ACCORDANCE WITH THIS DRAWING AND THE MANUFACTURERS SPECIFICATIONS, UNLESS OTHERWISE STATED IN MANUFACTURERS CONTRACT.
- UNIT MUST BE INSTALLED ON LEVEL BASE. MANUFACTURER RECOMMENDS A MINIMUM 6" LEVEL ROCK BASE UNLESS SPECIFIED BY THE PROJECT ENGINEER. CONTRACTOR IS RESPONSIBLE TO VERIFY PROJECT ENGINEERS RECOMMENDED BASE SPECIFICATIONS.
- ALL PIPES MUST BE FLUSH WITH INSIDE SURFACE OF CONCRETE. (PIPES CANNOT INTRUDE BEYOND FLUSH). INVERT OF OUTFLOW PIPE MUST BE FLUSH WITH DISCHARGE CHAMBER FLOOR. ALL GAPS AROUND PIPES SHALL BE SEALED WATER TIGHT WITH A NON-SHRINK GROUT PER MANUFACTURERS STANDARD CONNECTION DETAIL AND SHALL MEET OR EXCEED REGIONAL PIPE CONNECTION STANDARDS.
- CONTRACTOR TO SUPPLY AND INSTALL ALL EXTERNAL CONNECTING PIPES.
- CONTRACTOR RESPONSIBLE FOR INSTALLATION OF ALL RISERS, MANHOLES, AND HATCHES. CONTRACTOR TO GROUT ALL MANHOLES AND HATCHES TO MATCH FINISHED SURFACE UNLESS SPECIFIED OTHERWISE.
- DRIP OR SPRAY IRRIGATION REQUIRED ON ALL UNITS WITH VEGETATION.

GENERAL NOTES

- MANUFACTURER TO PROVIDE ALL MATERIALS UNLESS OTHERWISE NOTED.
- ALL DIMENSIONS, ELEVATIONS, SPECIFICATIONS AND CAPACITIES ARE SUBJECT TO CHANGE. FOR PROJECT SPECIFIC DRAWINGS DETAILING EXACT DIMENSIONS, WEIGHTS AND ACCESSORIES PLEASE CONTACT MANUFACTURER.

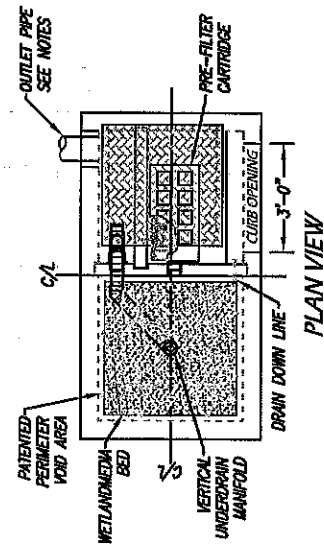

PLAN VIEW

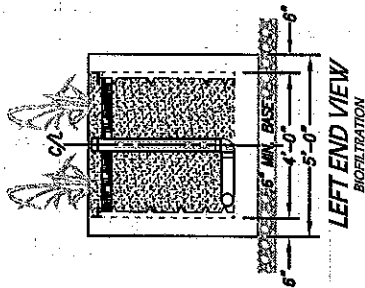

LEFT END VIEW
BIOFILTRATION

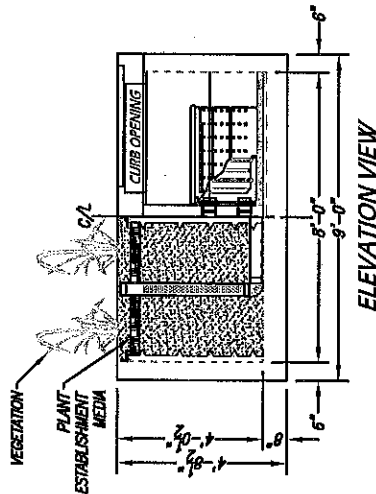

ELEVATION VIEW

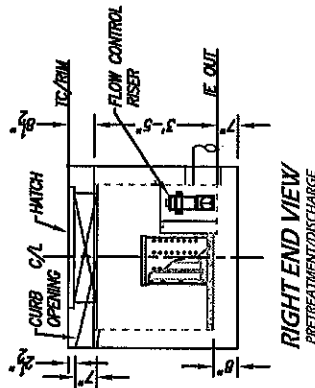

RIGHT END VIEW
PRETREATMENT/DISCHARGE

TREATMENT FLOW (GFS)	0.115
OPERATING HEAD (FT)	3.4
PRETREATMENT LOADING RATE (GPM/SF)	TBD
WETLAND MEDIA LOADING RATE (GPM/SF)	1.0

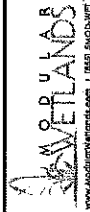

PROPRIETARY AND CONFIDENTIAL:
THE INFORMATION CONTAINED IN THIS DRAWING IS THE SOLE PROPERTY OF WETLANDS. NO REPRODUCTION OR TRANSMISSION IN ANY FORM OR BY ANY MEANS, WITHOUT THE WRITTEN PERMISSION OF WETLANDS IS PERMITTED.

MWS-L-4-8-C
STORMWATER BIOFILTRATION SYSTEM
STANDARD DETAIL

SITE SPECIFIC DATA	
PROJECT NUMBER	
PROJECT NAME	
PROJECT LOCATION	
STRUCTURE ID	
TREATMENT REQUIRED	FLOW BASED (GFS)
VOLUME BASED (CF)	
TREATMENT HGL AVAILABLE (FT)	
PEAK BYPASS REQUIRED (GFS) - IF APPLICABLE	
PIPE DATA	MATERIAL DIAMETER
INLET PIPE 1	1.5"
INLET PIPE 2	
OUTLET PIPE	
PRETREATMENT	BIOFILTRATION DISCHARGE
RIM ELEVATION	
SURFACE LOAD	PARKWAY OPEN PLANTER PARKWAY
FRAME & COVER	36" x 36" N/A
WETLANDMEDIA VOLUME (CY)	2.37
WETLANDMEDIA DELIVERY METHOD	TBD
ORIFICE SIZE (DIA. INCHES)	#1.22"
MAXIMUM PICK WEIGHT (LBS)	16500
NOTES:	

INSTALLATION NOTES

- CONTRACTOR TO PROVIDE ALL LABOR, EQUIPMENT, MATERIALS AND INCIDENTALS REQUIRED TO OFFLOAD AND INSTALL THE SYSTEM AND APPURTENANCES IN ACCORDANCE WITH THIS DRAWING AND THE MANUFACTURERS SPECIFICATIONS, UNLESS OTHERWISE STATED IN MANUFACTURERS CONTRACT.
- UNIT MUST BE INSTALLED ON LEVEL BASE. MANUFACTURER RECOMMENDS A MINIMUM 6" LEVEL ROCK BASE UNLESS SPECIFIED BY THE PROJECT ENGINEER. CONTRACTOR IS RESPONSIBLE TO VERIFY PROJECT ENGINEERS RECOMMENDED BASE SPECIFICATIONS.
- ALL PIPES MUST BE FLUSH WITH INSIDE SURFACE OF CONCRETE. (PIPES CANNOT INTRUDE BEYOND FLUSH). INVERT OF OUTFLOW PIPE MUST BE FLUSH WITH DISCHARGE CHAMBER FLOOR. ALL CAPS AROUND PIPES SHALL BE SEALED WATER TIGHT WITH A NON-SHRINK GROUT PER MANUFACTURERS STANDARD CONNECTION DETAIL AND SHALL MEET OR EXCEED REGIONAL PIPE CONNECTION STANDARDS.
- CONTRACTOR TO SUPPLY AND INSTALL ALL EXTERNAL CONNECTING PIPES.
- CONTRACTOR RESPONSIBLE FOR INSTALLATION OF ALL RISERS, MANHOLES, AND HATCHES. CONTRACTOR TO GROUT ALL MANHOLES AND HATCHES TO MATCH FINISHED SURFACE UNLESS SPECIFIED OTHERWISE.
- DRIP OR SPRAY IRRIGATION REQUIRED ON ALL UNITS WITH VEGETATION.

GENERAL NOTES

- MANUFACTURER TO PROVIDE ALL MATERIALS UNLESS OTHERWISE NOTED.
- ALL DIMENSIONS, ELEVATIONS, SPECIFICATIONS AND CAPACITIES ARE SUBJECT TO CHANGE. FOR PROJECT SPECIFIC DRAWINGS DETAILING EXACT DIMENSIONS, MATERIALS AND ACCESSORIES PLEASE CONTACT MANUFACTURER.

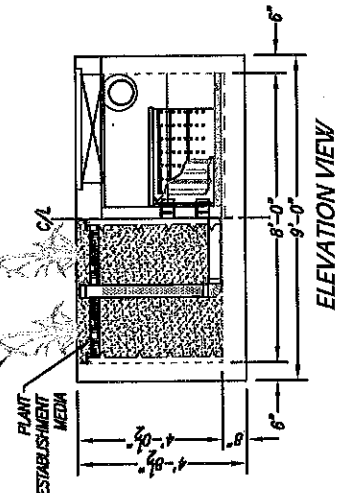
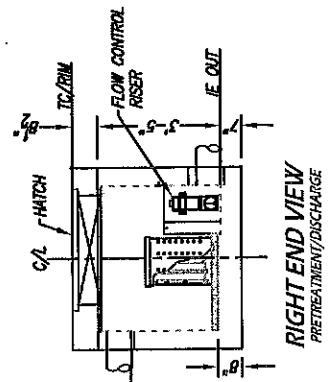
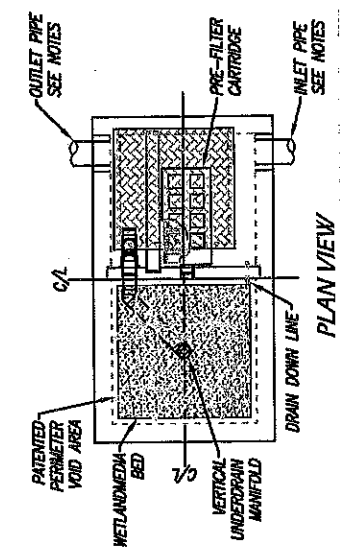
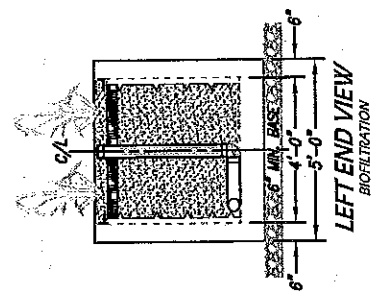

TREATMENT FLOW (GFS)	0.115
OPERATING HEAD (FT)	3.4
PRETREATMENT LOADING RATE (GPM/SF)	TBD
WETLAND MEDIA LOADING RATE (GPM/SF)	1.0

MWS-L-4-8-V
STORMWATER BIOFILTRATION SYSTEM
STANDARD DETAIL



PROPRIETARY AND CONFIDENTIAL:
 THE INFORMATION CONTAINED IN THIS DRAWING IS THE SOLE PROPERTY OF M. P. WETLANDS SYSTEMS, INC. THE DESIGN OR INVENTION OF ANY PART OF THIS DRAWING IS THE PROPERTY OF M. P. WETLANDS SYSTEMS, INC. NO PART OF THIS DRAWING IS TO BE REPRODUCED OR TRANSMITTED IN ANY FORM OR BY ANY MEANS, ELECTRONIC OR MECHANICAL, INCLUDING PHOTOCOPYING, RECORDING, OR BY ANY INFORMATION STORAGE AND RETRIEVAL SYSTEM, WITHOUT THE WRITTEN PERMISSION OF M. P. WETLANDS SYSTEMS, INC.

SITE SPECIFIC DATA	
PROJECT NAME	
PROJECT LOCATION	
STRUCTURE ID	
TREATMENT REQUIRED	FLOW BASED (GFS)
VOLUME BASED (CF)	
TREATMENT HGL AVAILABLE (FT)	
PEAK BYPASS REQUIRED (GFS) - IF APPLICABLE	
PIPE DATA	I.E. MATERIAL DIAMETER
INLET PIPE 1	
INLET PIPE 2	
OUTLET PIPE	
RIM ELEVATION	PRETREATMENT BIOPFILTRATION DISCHARGE
SURFACE LOAD	PARKWAY OPEN PLANTER PARKWAY
FRAME & COVER	#30" N/A #24" 3.05
WETLANDMEDIA VOLUME (CY)	TBD
WETLANDMEDIA DELIVERY METHOD	#1.71" 27000
ORIFICE SIZE (DIA. INCHES)	
MAXIMUM PICK WEIGHT (LBS)	
NOTES:	

INSTALLATION NOTES

- CONTRACTOR TO PROVIDE ALL LABOR, EQUIPMENT, MATERIALS AND INCIDENTALS REQUIRED TO OFFLOAD AND INSTALL THE SYSTEM AND APPURTENANCES IN ACCORDANCE WITH THIS DRAWING AND THE MANUFACTURERS SPECIFICATIONS, UNLESS OTHERWISE STATED IN MANUFACTURERS CONTRACT.
- UNIT MUST BE INSTALLED ON LEVEL BASE. MANUFACTURER RECOMMENDS A MINIMUM 6" LEVEL ROCK BASE UNLESS SPECIFIED BY THE PROJECT ENGINEER. CONTRACTOR IS RESPONSIBLE TO VERIFY PROJECT ENGINEERS RECOMMENDED BASE SPECIFICATIONS.
- ALL PIPES MUST BE FLUSH WITH INSIDE SURFACE OF CONCRETE. (PIPES CANNOT INTRUDE BEYOND FLUSH) INVERT OF OUTFLOW PIPE MUST BE FLUSH WITH DISCHARGE CHAMBER FLOOR. ALL GAPS AROUND PIPES SHALL BE SEALED WATER TIGHT WITH A NON-SHRINK GROUT PER MANUFACTURERS STANDARD CONNECTION DETAIL AND SHALL MEET OR EXCEED REGIONAL PIPE CONNECTION STANDARDS. CONTRACTOR TO SUPPLY AND INSTALL ALL EXTERNAL CONNECTING PIPES.
- CONTRACTOR RESPONSIBLE FOR INSTALLATION OF ALL RISERS, MANHOLES, AND HATCHES. CONTRACTOR TO GROUT ALL MANHOLES AND HATCHES TO MATCH FINISHED SURFACE UNLESS SPECIFIED OTHERWISE.
- DRP OR SPRAY IRRIGATION REQUIRED ON ALL UNITS WITH VEGETATION.

GENERAL NOTES

- MANUFACTURER TO PROVIDE ALL MATERIALS UNLESS OTHERWISE NOTED.
- ALL DIMENSIONS, ELEVATIONS, SPECIFICATIONS AND CAPACITIES ARE SUBJECT TO CHANGE. FOR PROJECT SPECIFIC DRAWINGS DETAILING EXACT DIMENSIONS, WEIGHTS AND ACCESSORIES PLEASE CONTACT MANUFACTURER.

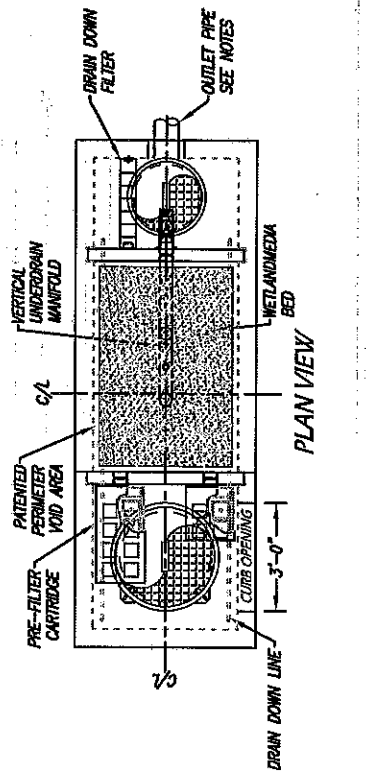

PLAN VIEW

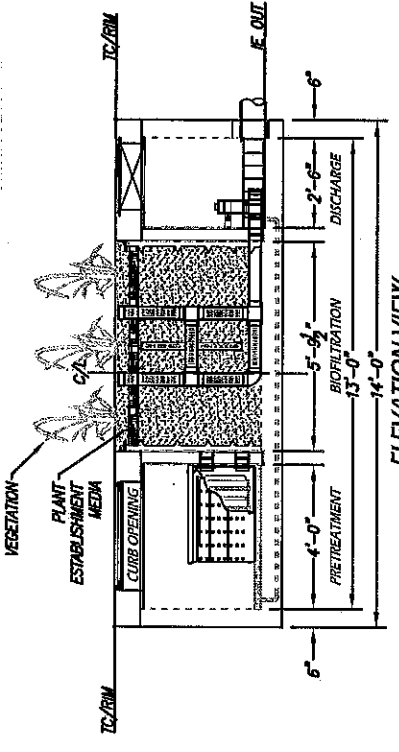

ELEVATION VIEW

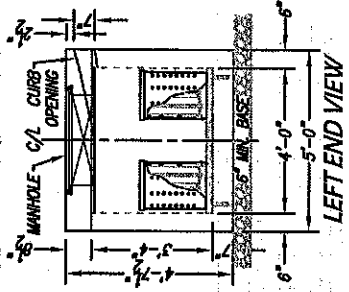

LEFT END VIEW

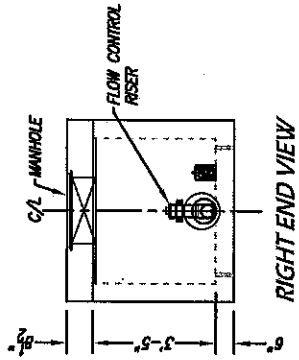

RIGHT END VIEW

TREATMENT FLOW (CFS)	0.144
OPERATING HEAD (FT)	3.4
PRETREATMENT LOADING RATE (GPM/SF)	TBD
WETLAND MEDIA LOADING RATE (GPM/SF)	1.0

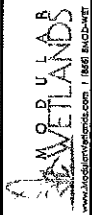

PROPRIETARY AND CONFIDENTIAL:
 THE INFORMATION CONTAINED IN THIS DRAWING IS THE SOLE PROPERTY OF MODULAR WETLANDS SYSTEMS. ANY REPRODUCTION IN PART OR AS A WHOLE WITHOUT THE WRITTEN PERMISSION OF MODULAR WETLANDS SYSTEMS IS PROHIBITED.

MWS-L-4-13-C
STORMWATER BIOFILTRATION SYSTEM
STANDARD DETAIL

SITE SPECIFIC DATA	
PROJECT NAME	
PROJECT LOCATION	
STRUCTURE ID	
TREATMENT REQUIRED	FLOW BASED (CFS)
VOLUME BASED (CF)	
TREATMENT HGL AVAILABLE (FT)	
PEAK BYPASS REQUIRED (CFS) - IF APPLICABLE	
PIPE DATA	I.E. MATERIAL DIAMETER
INLET PIPE 1	
INLET PIPE 2	
OUTLET PIPE	
PRETREATMENT	BIOFILTRATION DISCHARGE
RIM ELEVATION	
SURFACE LOAD	PARKWAY OPEN PLANTER PARKWAY
FRAME & COVER	#30" N/A #24" 3.05
WETLAND MEDIA VOLUME (CY)	TBD
WETLAND MEDIA DELIVERY METHOD	
ORIFICE SIZE (DIA. INCHES)	#1.71"
MAXIMUM PICK WEIGHT (LBS)	27000
NOTES:	

INSTALLATION NOTES

- CONTRACTOR TO PROVIDE ALL LABOR, EQUIPMENT, MATERIALS AND INCIDENTALS REQUIRED TO OBTAIN AND INSTALL THE SYSTEM AND APPURTENANCES IN ACCORDANCE WITH THIS DRAWING AND THE MANUFACTURER'S SPECIFICATIONS, UNLESS OTHERWISE STATED IN MANUFACTURER'S CONTRACT.
- UNIT MUST BE INSTALLED ON LEVEL BASE. MANUFACTURER RECOMMENDS A MINIMUM 6" LEVEL ROCK BASE UNLESS SPECIFIED BY THE PROJECT ENGINEER. CONTRACTOR IS RESPONSIBLE TO VERIFY PROJECT ENGINEER'S RECOMMENDED BASE SPECIFICATIONS.
- ALL PIPES MUST BE FLUSH WITH INSIDE SURFACE OF CONCRETE. (PIPES CANNOT INTRUDE BEYOND FLUSH). INVERT OF OUTFLOW PIPE MUST BE FLUSH WITH DISCHARGE CHAMBER FLOOR. ALL GAPS AROUND PIPES SHALL BE SEALED WATER TIGHT WITH A NON-SHRINK GROUT PER MANUFACTURER'S STANDARD CONNECTION DETAIL AND SHALL MEET OR EXCEED REGIONAL PIPE CONNECTION STANDARDS. CONTRACTOR TO SUPPLY AND INSTALL ALL EXTERNAL CONNECTING PIPES.
- CONTRACTOR RESPONSIBLE FOR INSTALLATION OF ALL RISERS, MANHOLES, AND HATCHES. CONTRACTOR TO GROUT ALL MANHOLES AND HATCHES TO MATCH FINISHED SURFACE UNLESS SPECIFIED OTHERWISE. DRIP OR SPRAY IRRIGATION REQUIRED ON ALL UNITS WITH VEGETATION.

GENERAL NOTES

- MANUFACTURER TO PROVIDE ALL MATERIALS UNLESS OTHERWISE NOTED.
- ALL DIMENSIONS, ELEVATIONS, SPECIFICATIONS AND CAPACITIES ARE SUBJECT TO CHANGE. FOR PROJECT SPECIFIC DRAWINGS DETAILING EXACT DIMENSIONS, WEIGHTS AND ACCESSORIES PLEASE CONTACT MANUFACTURER.

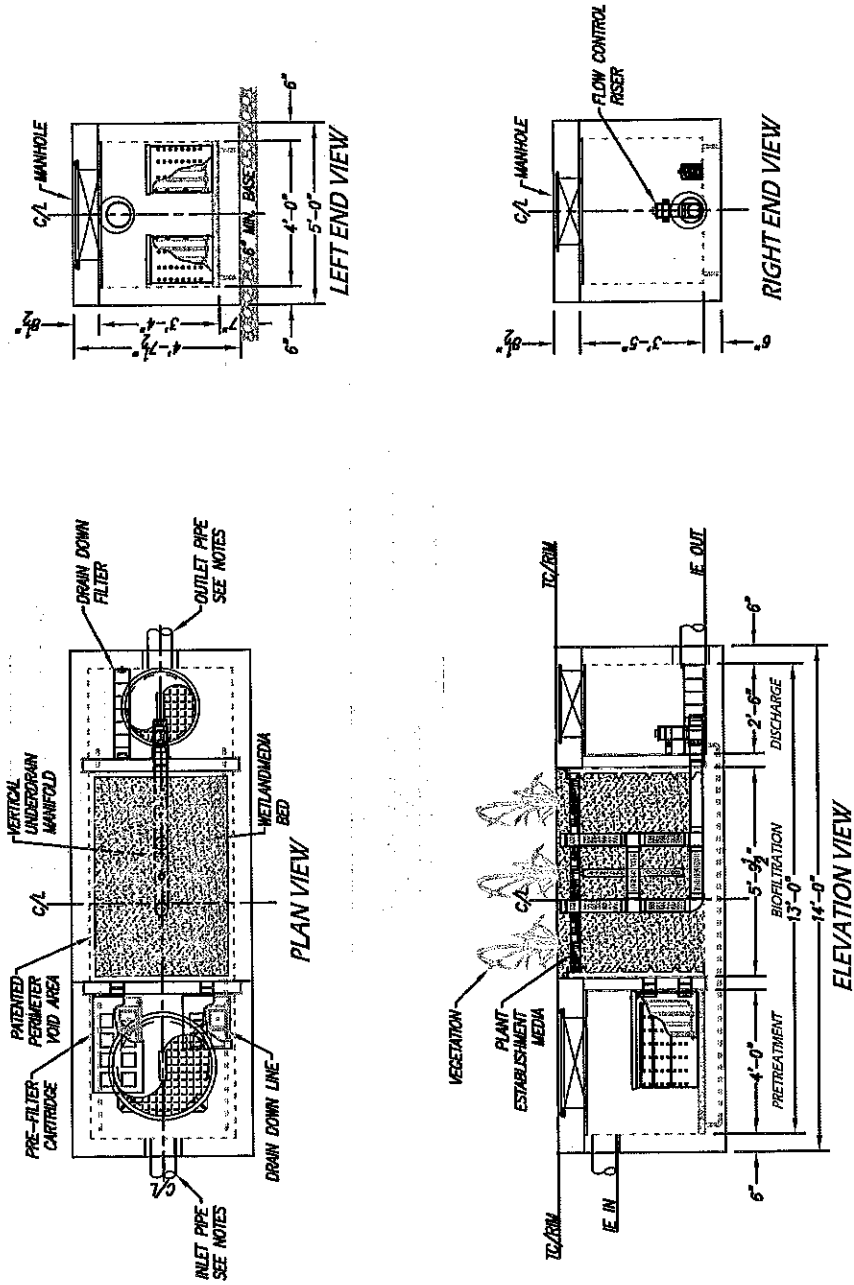

TREATMENT FLOW (CFS)	0.144
OPERATING HEAD (FT)	3.4
PRETREATMENT LOADING RATE (GPM/SF)	TBD
WETLAND MEDIA LOADING RATE (GPM/SF)	1.0

MWS-L-4-13-V
STORMWATER BIOFILTRATION SYSTEM
STANDARD DETAIL



PROPRIETARY AND CONFIDENTIAL:
 THE INFORMATION CONTAINED IN THIS DRAWING IS THE SOLE PROPERTY OF MODULAR WETLANDS SYSTEMS, INC. NO PART OF THIS DRAWING OR THE INFORMATION CONTAINED HEREIN IS TO BE REPRODUCED OR TRANSMITTED IN ANY FORM OR BY ANY MEANS, ELECTRONIC OR MECHANICAL, INCLUDING PHOTOCOPYING, RECORDING, OR BY ANY INFORMATION STORAGE AND RETRIEVAL SYSTEM, WITHOUT THE WRITTEN PERMISSION OF MODULAR WETLANDS SYSTEMS, INC.

SITE SPECIFIC DATA	
PROJECT NAME	
PROJECT LOCATION	
STRUCTURE ID	
TREATMENT REQUIRED	FLOW BASED (GFS)
VOLUME BASED (CT)	
TREATMENT HGL AVAILABLE (FT)	
PEAK BYPASS REQUIRED (GFS) - IF APPLICABLE	
PIPE DATA	I.E. MATERIAL DIAMETER
INLET PIPE 1	
INLET PIPE 2	
OUTLET PIPE	
RIM ELEVATION	PRETREATMENT BIOFILTRATION DISCHARGE
SURFACE LOAD	PARKWAY OPEN PLANTER PARKWAY
FRAME & COVER	#30" N/A #24"
WETLAND MEDIA VOLUME (CY)	4.30 TBD
WETLAND MEDIA DELIVERY METHOD	
ORIFICE SIZE (DIA. INCHES)	#1.89"
MAXIMUM PICK WEIGHT (LBS)	31000
NOTES	

INSTALLATION NOTES

- CONTRACTOR TO PROVIDE ALL LABOR, EQUIPMENT, MATERIALS AND INCIDENTALS REQUIRED TO O/FLOAD AND INSTALL THE SYSTEM AND APPURTENANCES IN ACCORDANCE WITH THIS DRAWING AND THE MANUFACTURERS SPECIFICATIONS, UNLESS OTHERWISE STATED IN MANUFACTURERS CONTRACT.
- UNIT MUST BE INSTALLED ON LEVEL BASE. MANUFACTURER RECOMMENDS A MINIMUM 6" LEVEL ROCK BASE UNLESS SPECIFIED BY THE PROJECT ENGINEER. CONTRACTOR IS RESPONSIBLE TO VERIFY PROJECT ENGINEERS RECOMMENDED BASE SPECIFICATIONS.
- ALL PIPES MUST BE FLUSH WITH INSIDE SURFACE OF CONCRETE. (PIPES CANNOT INTRUDE BEYOND FLUSH). INVERT OF OUTFLOW PIPE MUST BE FLUSH WITH DISCHARGE CHAMBER FLOOR. ALL CAPS AROUND PIPES SHALL BE SEALED WATER TIGHT WITH A NON-SHRINK GROUT PER MANUFACTURERS STANDARD CONNECTION DETAIL AND SHALL MEET OR EXCEED REGIONAL PIPE CONNECTION STANDARDS.
- CONTRACTOR TO SUPPLY AND INSTALL ALL EXTERNAL CONNECTING PIPES.
- CONTRACTOR RESPONSIBLE FOR INSTALLATION OF ALL RISERS, MANHOLES, AND HATCHES. CONTRACTOR TO GROUT ALL MANHOLES AND HATCHES TO MATCH FINISHED SURFACE UNLESS SPECIFIED OTHERWISE.
- DRIP OR SPRAY IRRIGATION REQUIRED ON ALL UNITS WITH VEGETATION.

GENERAL NOTES

- MANUFACTURER TO PROVIDE ALL MATERIALS UNLESS OTHERWISE NOTED.
- ALL DIMENSIONS, ELEVATIONS, SPECIFICATIONS AND CAPACITIES ARE SUBJECT TO CHANGE. FOR PROJECT SPECIFIC DRAWINGS DETAILING EXACT DIMENSIONS, HEIGHTS AND ACCESSORIES PLEASE CONTACT MANUFACTURER.

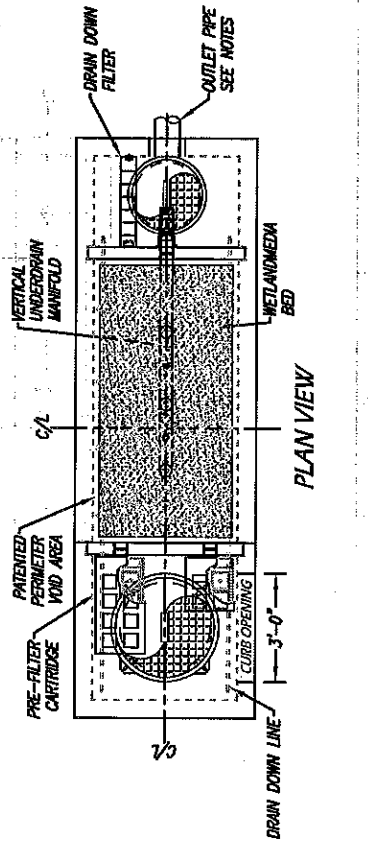

PLAN VIEW

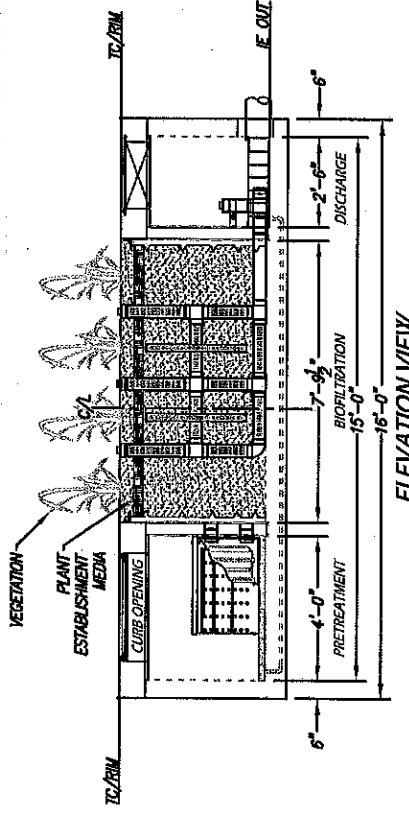

ELEVATION VIEW

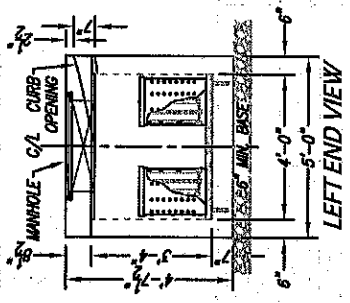

LEFT END VIEW

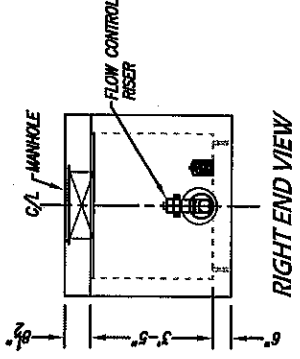

RIGHT END VIEW

TREATMENT FLOW (GFS)	0.175
OPERATING HEAD (FT)	3.4
PRETREATMENT LOADING RATE (GPM/SF)	TBD
WETLAND MEDIA LOADING RATE (GPM/SF)	1.0

MWS-L-4-15-C
STORMWATER BIOFILTRATION SYSTEM
STANDARD DETAIL

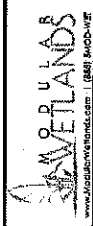

PROPRIETARY AND CONFIDENTIAL:
THE INFORMATION CONTAINED IN THIS DRAWING IS THE SOLE PROPERTY OF WETLANDS. IT IS TO BE USED ONLY FOR THE PROJECT AND SITE SPECIFICALLY IDENTIFIED HEREIN. PERMISSION OF WETLANDS SYSTEMS IS REQUIRED.
WETLANDS SYSTEMS, INC. (800) 840-5474

THE PRODUCT DESCRIBED MAY BE PROVIDED BY ONE OR MORE OF THE FOLLOWING US PATENTS: 6,882,450; 6,882,451; 6,882,452; 6,882,453; 6,882,454; 6,882,455; 6,882,456; 6,882,457; 6,882,458; 6,882,459; 6,882,460; 6,882,461; 6,882,462; 6,882,463; 6,882,464; 6,882,465; 6,882,466; 6,882,467; 6,882,468; 6,882,469; 6,882,470; 6,882,471; 6,882,472; 6,882,473; 6,882,474; 6,882,475; 6,882,476; 6,882,477; 6,882,478; 6,882,479; 6,882,480; 6,882,481; 6,882,482; 6,882,483; 6,882,484; 6,882,485; 6,882,486; 6,882,487; 6,882,488; 6,882,489; 6,882,490; 6,882,491; 6,882,492; 6,882,493; 6,882,494; 6,882,495; 6,882,496; 6,882,497; 6,882,498; 6,882,499; 6,882,500; 6,882,501; 6,882,502; 6,882,503; 6,882,504; 6,882,505; 6,882,506; 6,882,507; 6,882,508; 6,882,509; 6,882,510; 6,882,511; 6,882,512; 6,882,513; 6,882,514; 6,882,515; 6,882,516; 6,882,517; 6,882,518; 6,882,519; 6,882,520; 6,882,521; 6,882,522; 6,882,523; 6,882,524; 6,882,525; 6,882,526; 6,882,527; 6,882,528; 6,882,529; 6,882,530; 6,882,531; 6,882,532; 6,882,533; 6,882,534; 6,882,535; 6,882,536; 6,882,537; 6,882,538; 6,882,539; 6,882,540; 6,882,541; 6,882,542; 6,882,543; 6,882,544; 6,882,545; 6,882,546; 6,882,547; 6,882,548; 6,882,549; 6,882,550; 6,882,551; 6,882,552; 6,882,553; 6,882,554; 6,882,555; 6,882,556; 6,882,557; 6,882,558; 6,882,559; 6,882,560; 6,882,561; 6,882,562; 6,882,563; 6,882,564; 6,882,565; 6,882,566; 6,882,567; 6,882,568; 6,882,569; 6,882,570; 6,882,571; 6,882,572; 6,882,573; 6,882,574; 6,882,575; 6,882,576; 6,882,577; 6,882,578; 6,882,579; 6,882,580; 6,882,581; 6,882,582; 6,882,583; 6,882,584; 6,882,585; 6,882,586; 6,882,587; 6,882,588; 6,882,589; 6,882,590; 6,882,591; 6,882,592; 6,882,593; 6,882,594; 6,882,595; 6,882,596; 6,882,597; 6,882,598; 6,882,599; 6,882,600; 6,882,601; 6,882,602; 6,882,603; 6,882,604; 6,882,605; 6,882,606; 6,882,607; 6,882,608; 6,882,609; 6,882,610; 6,882,611; 6,882,612; 6,882,613; 6,882,614; 6,882,615; 6,882,616; 6,882,617; 6,882,618; 6,882,619; 6,882,620; 6,882,621; 6,882,622; 6,882,623; 6,882,624; 6,882,625; 6,882,626; 6,882,627; 6,882,628; 6,882,629; 6,882,630; 6,882,631; 6,882,632; 6,882,633; 6,882,634; 6,882,635; 6,882,636; 6,882,637; 6,882,638; 6,882,639; 6,882,640; 6,882,641; 6,882,642; 6,882,643; 6,882,644; 6,882,645; 6,882,646; 6,882,647; 6,882,648; 6,882,649; 6,882,650; 6,882,651; 6,882,652; 6,882,653; 6,882,654; 6,882,655; 6,882,656; 6,882,657; 6,882,658; 6,882,659; 6,882,660; 6,882,661; 6,882,662; 6,882,663; 6,882,664; 6,882,665; 6,882,666; 6,882,667; 6,882,668; 6,882,669; 6,882,670; 6,882,671; 6,882,672; 6,882,673; 6,882,674; 6,882,675; 6,882,676; 6,882,677; 6,882,678; 6,882,679; 6,882,680; 6,882,681; 6,882,682; 6,882,683; 6,882,684; 6,882,685; 6,882,686; 6,882,687; 6,882,688; 6,882,689; 6,882,690; 6,882,691; 6,882,692; 6,882,693; 6,882,694; 6,882,695; 6,882,696; 6,882,697; 6,882,698; 6,882,699; 6,882,700; 6,882,701; 6,882,702; 6,882,703; 6,882,704; 6,882,705; 6,882,706; 6,882,707; 6,882,708; 6,882,709; 6,882,710; 6,882,711; 6,882,712; 6,882,713; 6,882,714; 6,882,715; 6,882,716; 6,882,717; 6,882,718; 6,882,719; 6,882,720; 6,882,721; 6,882,722; 6,882,723; 6,882,724; 6,882,725; 6,882,726; 6,882,727; 6,882,728; 6,882,729; 6,882,730; 6,882,731; 6,882,732; 6,882,733; 6,882,734; 6,882,735; 6,882,736; 6,882,737; 6,882,738; 6,882,739; 6,882,740; 6,882,741; 6,882,742; 6,882,743; 6,882,744; 6,882,745; 6,882,746; 6,882,747; 6,882,748; 6,882,749; 6,882,750; 6,882,751; 6,882,752; 6,882,753; 6,882,754; 6,882,755; 6,882,756; 6,882,757; 6,882,758; 6,882,759; 6,882,760; 6,882,761; 6,882,762; 6,882,763; 6,882,764; 6,882,765; 6,882,766; 6,882,767; 6,882,768; 6,882,769; 6,882,770; 6,882,771; 6,882,772; 6,882,773; 6,882,774; 6,882,775; 6,882,776; 6,882,777; 6,882,778; 6,882,779; 6,882,780; 6,882,781; 6,882,782; 6,882,783; 6,882,784; 6,882,785; 6,882,786; 6,882,787; 6,882,788; 6,882,789; 6,882,790; 6,882,791; 6,882,792; 6,882,793; 6,882,794; 6,882,795; 6,882,796; 6,882,797; 6,882,798; 6,882,799; 6,882,800; 6,882,801; 6,882,802; 6,882,803; 6,882,804; 6,882,805; 6,882,806; 6,882,807; 6,882,808; 6,882,809; 6,882,810; 6,882,811; 6,882,812; 6,882,813; 6,882,814; 6,882,815; 6,882,816; 6,882,817; 6,882,818; 6,882,819; 6,882,820; 6,882,821; 6,882,822; 6,882,823; 6,882,824; 6,882,825; 6,882,826; 6,882,827; 6,882,828; 6,882,829; 6,882,830; 6,882,831; 6,882,832; 6,882,833; 6,882,834; 6,882,835; 6,882,836; 6,882,837; 6,882,838; 6,882,839; 6,882,840; 6,882,841; 6,882,842; 6,882,843; 6,882,844; 6,882,845; 6,882,846; 6,882,847; 6,882,848; 6,882,849; 6,882,850; 6,882,851; 6,882,852; 6,882,853; 6,882,854; 6,882,855; 6,882,856; 6,882,857; 6,882,858; 6,882,859; 6,882,860; 6,882,861; 6,882,862; 6,882,863; 6,882,864; 6,882,865; 6,882,866; 6,882,867; 6,882,868; 6,882,869; 6,882,870; 6,882,871; 6,882,872; 6,882,873; 6,882,874; 6,882,875; 6,882,876; 6,882,877; 6,882,878; 6,882,879; 6,882,880; 6,882,881; 6,882,882; 6,882,883; 6,882,884; 6,882,885; 6,882,886; 6,882,887; 6,882,888; 6,882,889; 6,882,890; 6,882,891; 6,882,892; 6,882,893; 6,882,894; 6,882,895; 6,882,896; 6,882,897; 6,882,898; 6,882,899; 6,882,900; 6,882,901; 6,882,902; 6,882,903; 6,882,904; 6,882,905; 6,882,906; 6,882,907; 6,882,908; 6,882,909; 6,882,910; 6,882,911; 6,882,912; 6,882,913; 6,882,914; 6,882,915; 6,882,916; 6,882,917; 6,882,918; 6,882,919; 6,882,920; 6,882,921; 6,882,922; 6,882,923; 6,882,924; 6,882,925; 6,882,926; 6,882,927; 6,882,928; 6,882,929; 6,882,930; 6,882,931; 6,882,932; 6,882,933; 6,882,934; 6,882,935; 6,882,936; 6,882,937; 6,882,938; 6,882,939; 6,882,940; 6,882,941; 6,882,942; 6,882,943; 6,882,944; 6,882,945; 6,882,946; 6,882,947; 6,882,948; 6,882,949; 6,882,950; 6,882,951; 6,882,952; 6,882,953; 6,882,954; 6,882,955; 6,882,956; 6,882,957; 6,882,958; 6,882,959; 6,882,960; 6,882,961; 6,882,962; 6,882,963; 6,882,964; 6,882,965; 6,882,966; 6,882,967; 6,882,968; 6,882,969; 6,882,970; 6,882,971; 6,882,972; 6,882,973; 6,882,974; 6,882,975; 6,882,976; 6,882,977; 6,882,978; 6,882,979; 6,882,980; 6,882,981; 6,882,982; 6,882,983; 6,882,984; 6,882,985; 6,882,986; 6,882,987; 6,882,988; 6,882,989; 6,882,990; 6,882,991; 6,882,992; 6,882,993; 6,882,994; 6,882,995; 6,882,996; 6,882,997; 6,882,998; 6,882,999; 6,882,1000.

SITE SPECIFIC DATA	
PROJECT NAME	
PROJECT LOCATION	
STRUCTURE ID	
TREATMENT REQUIRED	FLOW BASED (GFS)
VOLUME BASED (CF)	
TREATMENT HGL AVAILABLE (FT)	
PEAK BYPASS REQUIRED (GFS) - IF APPLICABLE	
PIPE DATA	I.E. MATERIAL DIAMETER
INLET PIPE 1	
INLET PIPE 2	
OUTLET PIPE	
PRETREATMENT	BIOFILTRATION DISCHARGE
RIM ELEVATION	
SURFACE LOAD	PARKWAY OPEN PLANTER
FRAME & COVER	#30" N/A #24"
WETLAND MEDIA VOLUME (CY)	4.30
ORIFICE SIZE (DIA. INCHES)	TBD
MAXIMUM PICK WEIGHT (LBS)	#1.89"
NOTES:	31000

INSTALLATION NOTES

- CONTRACTOR TO PROVIDE ALL LABOR, EQUIPMENT, MATERIALS AND INCIDENTALS REQUIRED TO OUTFLOAD AND INSTALL THE SYSTEM AND ADJUSTMENTS IN ACCORDANCE WITH THIS DRAWING AND THE MANUFACTURERS SPECIFICATIONS, UNLESS OTHERWISE STATED IN MANUFACTURERS CONTRACT.
- UNIT MUST BE INSTALLED ON LEVEL BASE. MANUFACTURER RECOMMENDS A MINIMUM 6" LEVEL ROCK BASE UNLESS SPECIFIED BY THE PROJECT ENGINEER. CONTRACTOR IS RESPONSIBLE TO VERIFY PROJECT ENGINEERS RECOMMENDED BASE SPECIFICATIONS.
- ALL PIPES MUST BE FLUSH WITH INSIDE SURFACE OF CONCRETE. (PIPES CANNOT INTRUDE BEYOND FLUSH). INVERT OF OUTFLOW PIPE MUST BE FLUSH WITH DISCHARGE CHAMBER FLOOR. ALL GAPS AROUND PIPES SHALL BE SEALED WATER TIGHT WITH A NON-SHRINK GROUT PER MANUFACTURERS STANDARD CONNECTION DETAIL AND SHALL MEET OR EXCEED REGIONAL PIPE CONNECTION STANDARDS.
- CONTRACTOR TO SUPPLY AND INSTALL ALL EXTERNAL CONNECTING PIPES.
- CONTRACTOR RESPONSIBLE FOR INSTALLATION OF ALL RISERS, MANHOLES, AND HATCHES. CONTRACTOR TO GROUT ALL MANHOLES AND HATCHES TO MATCH FINISHED SURFACE UNLESS SPECIFIED OTHERWISE.
- DRIP OR SPRAY IRRIGATION REQUIRED ON ALL UNITS WITH VEGETATION.

GENERAL NOTES

- MANUFACTURER TO PROVIDE ALL MATERIALS UNLESS OTHERWISE NOTED.
- ALL DIMENSIONS, ELEVATIONS, SPECIFICATIONS AND CAPACITIES ARE SUBJECT TO CHANGE. FOR PROJECT SPECIFIC DRAWINGS DETAILING EXACT DIMENSIONS, WEIGHTS AND ACCESSORIES PLEASE CONTACT MANUFACTURER.

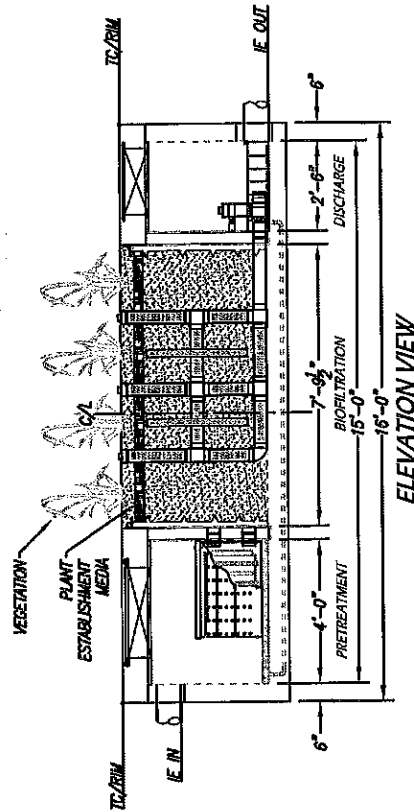
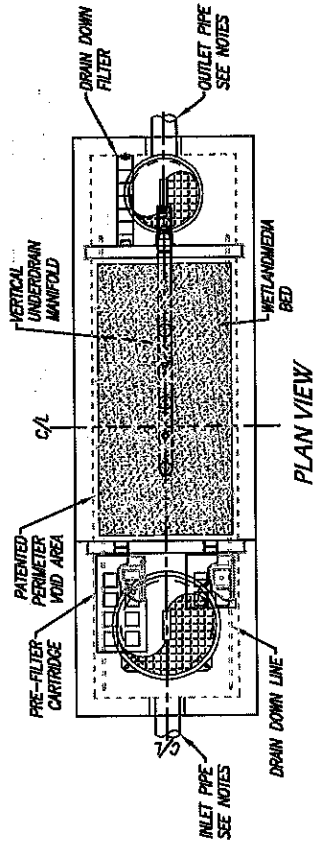
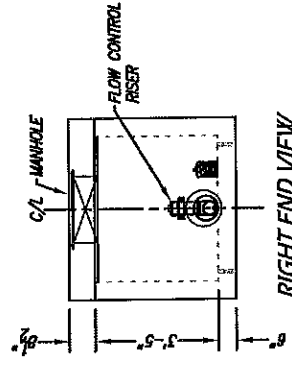
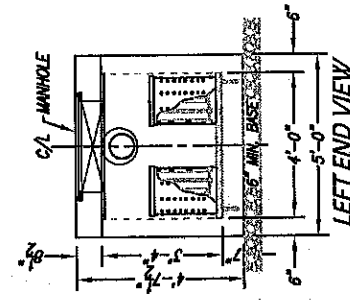

TREATMENT FLOW (GFS)	0.175
OPERATING HEAD (FT)	3.4
PRETREATMENT LOADING RATE (GPM/SF)	TBD
WETLAND MEDIA LOADING RATE (GPM/SF)	1.0

MWS-L-4-15-V
STORMWATER BIOFILTRATION SYSTEM
STANDARD DETAIL



PROPRIETARY AND CONFIDENTIAL.
THE INFORMATION CONTAINED IN THIS DRAWING IS THE SOLE PROPERTY OF MODULAR WETLANDS SYSTEMS, INC. THE WRITER'S PERMISSION OF MODULAR WETLANDS SYSTEMS IS REQUIRED.
REVISIONS OR OTHER PROJECTS BEING.

SITE SPECIFIC DATA	
PROJECT NAME	
PROJECT LOCATION	
STRUCTURE ID	
TREATMENT REQUIRED	FLOW BASED (GFS)
VOLUME BASED (CF)	
TREATMENT HGL AVAILABLE (FT)	
PEAK BYPASS REQUIRED (GFS) - IF APPLICABLE	
PIPE DATA	I.E. MATERIAL DIAMETER
INLET PIPE 1	
INLET PIPE 2	
OUTLET PIPE	
RIM ELEVATION	PRETREATMENT BIOFILTRATION DISCHARGE
SURFACE LOAD	PARKWAY OPEN PLANTER
FRAME & COVER	#30" N/A #24"
WETLAND MEDIA VOLUME (CY)	5.41
WETLAND MEDIA DELIVERY METHOD	TBD
ORIFICE SIZE (DIA. INCHES)	#2.05"
MAXIMUM PICK WEIGHT (LBS)	36000
NOTES:	

INSTALLATION NOTES

- CONTRACTOR TO PROVIDE ALL LABOR, EQUIPMENT, MATERIALS AND INCIDENTALS REQUIRED TO OFFLOAD AND INSTALL THE SYSTEM AND APPURTENANCES IN ACCORDANCE WITH THIS DRAWING AND THE MANUFACTURERS SPECIFICATIONS, UNLESS OTHERWISE STATED IN MANUFACTURERS CONTRACT.
- UNIT MUST BE INSTALLED ON LEVEL BASE. MANUFACTURER RECOMMENDS A MINIMUM 6" LEVEL ROCK BASE UNLESS SPECIFIED BY THE PROJECT ENGINEER. CONTRACTOR IS RESPONSIBLE TO VERIFY PROJECT ENGINEERS RECOMMENDED BASE SPECIFICATIONS.
- ALL PIPES MUST BE FLUSH WITH INSIDE SURFACE OF CONCRETE. (PIPES CANNOT INTRUDE BEYOND FLUSH). INVERT OF OUTFLOW PIPE MUST BE FLUSH WITH DISCHARGE CHAMBER FLOOR. ALL GAPS AROUND PIPES SHALL BE SEALED WATER TIGHT WITH A NON-SHRINK GROUT PER MANUFACTURERS STANDARD CONNECTION DETAIL AND SHALL MEET OR EXCEED REGIONAL PIPE CONNECTION STANDARDS.
- CONTRACTOR TO SUPPLY AND INSTALL ALL EXTERNAL CONNECTING PIPES.
- CONTRACTOR RESPONSIBLE FOR INSTALLATION OF ALL RISERS, MANHOLES, AND HATCHES. CONTRACTOR TO GROUT ALL MANHOLES AND HATCHES TO MATCH FINISHED SURFACE UNLESS SPECIFIED OTHERWISE.
- DRIP OR SPRAY IRRIGATION REQUIRED ON ALL UNITS WITH VEGETATION.

GENERAL NOTES

- MANUFACTURER TO PROVIDE ALL MATERIALS UNLESS OTHERWISE NOTED. ALL DIMENSIONS, ELEVATIONS, SPECIFICATIONS AND CAPACITIES ARE SUBJECT TO CHANGE. FOR PROJECT SPECIFIC DRAWINGS DETAILING EXACT DIMENSIONS, WEIGHTS AND ACCESSORIES PLEASE CONTACT MANUFACTURER.

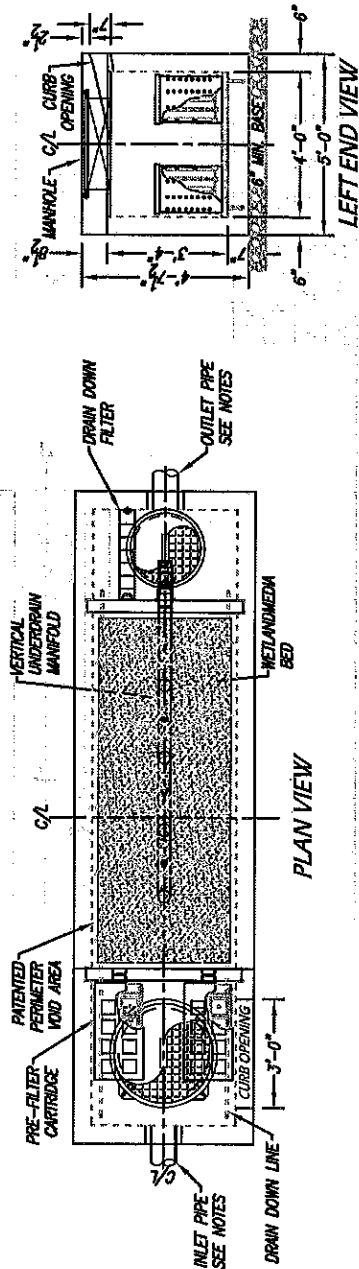

PLAN VIEW

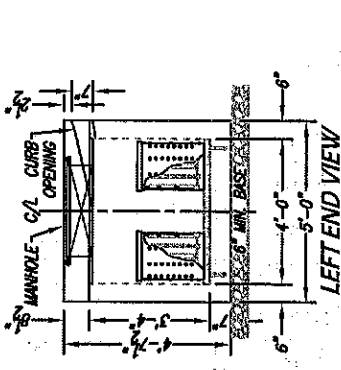

LEFT END VIEW

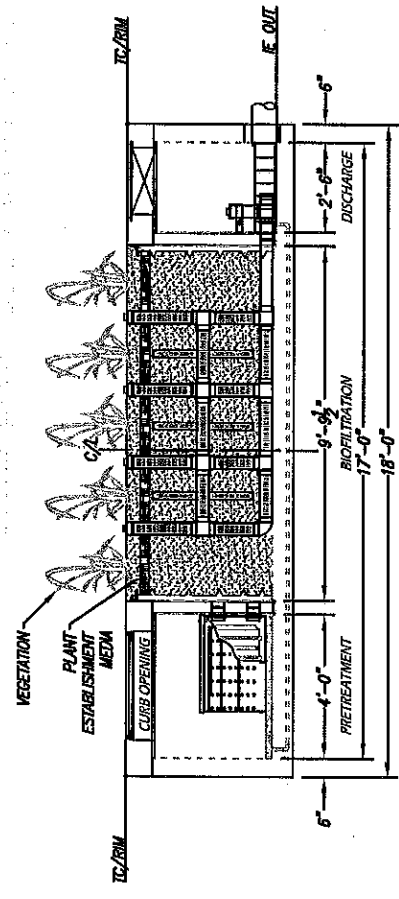

ELEVATION VIEW

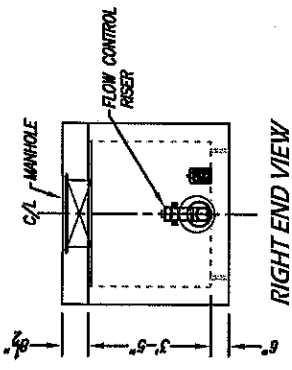

RIGHT END VIEW

TREATMENT FLOW (GFS)	0.206
OPERATING HEAD (FT)	3.4
PRETREATMENT LOADING RATE (GPM/SF)	TBD
WETLAND MEDIA LOADING RATE (GPM/SF)	1.0



PROPRIETARY AND CONFIDENTIAL:
THE INFORMATION CONTAINED IN THIS DRAWING IS THE SOLE PROPERTY OF WETLANDS. NO PART OF THIS DRAWING IS TO BE REPRODUCED OR TRANSMITTED IN ANY FORM OR BY ANY MEANS, ELECTRONIC OR MECHANICAL, INCLUDING PHOTOCOPYING, RECORDING, OR BY ANY INFORMATION STORAGE AND RETRIEVAL SYSTEM, WITHOUT THE WRITTEN PERMISSION OF WETLANDS. WETLANDS SYSTEMS IS PROHIBITED.

THE PRODUCT DESCRIBED MAY BE PROTECTED BY ONE OR MORE OF THE FOLLOWING US PATENTS: 6,812,412; 6,812,413; 6,812,414; 6,812,415; 6,812,416; 6,812,417; 6,812,418; 6,812,419; 6,812,420; 6,812,421; 6,812,422; 6,812,423; 6,812,424; 6,812,425; 6,812,426; 6,812,427; 6,812,428; 6,812,429; 6,812,430; 6,812,431; 6,812,432; 6,812,433; 6,812,434; 6,812,435; 6,812,436; 6,812,437; 6,812,438; 6,812,439; 6,812,440; 6,812,441; 6,812,442; 6,812,443; 6,812,444; 6,812,445; 6,812,446; 6,812,447; 6,812,448; 6,812,449; 6,812,450; 6,812,451; 6,812,452; 6,812,453; 6,812,454; 6,812,455; 6,812,456; 6,812,457; 6,812,458; 6,812,459; 6,812,460; 6,812,461; 6,812,462; 6,812,463; 6,812,464; 6,812,465; 6,812,466; 6,812,467; 6,812,468; 6,812,469; 6,812,470; 6,812,471; 6,812,472; 6,812,473; 6,812,474; 6,812,475; 6,812,476; 6,812,477; 6,812,478; 6,812,479; 6,812,480; 6,812,481; 6,812,482; 6,812,483; 6,812,484; 6,812,485; 6,812,486; 6,812,487; 6,812,488; 6,812,489; 6,812,490; 6,812,491; 6,812,492; 6,812,493; 6,812,494; 6,812,495; 6,812,496; 6,812,497; 6,812,498; 6,812,499; 6,812,500; 6,812,501; 6,812,502; 6,812,503; 6,812,504; 6,812,505; 6,812,506; 6,812,507; 6,812,508; 6,812,509; 6,812,510; 6,812,511; 6,812,512; 6,812,513; 6,812,514; 6,812,515; 6,812,516; 6,812,517; 6,812,518; 6,812,519; 6,812,520; 6,812,521; 6,812,522; 6,812,523; 6,812,524; 6,812,525; 6,812,526; 6,812,527; 6,812,528; 6,812,529; 6,812,530; 6,812,531; 6,812,532; 6,812,533; 6,812,534; 6,812,535; 6,812,536; 6,812,537; 6,812,538; 6,812,539; 6,812,540; 6,812,541; 6,812,542; 6,812,543; 6,812,544; 6,812,545; 6,812,546; 6,812,547; 6,812,548; 6,812,549; 6,812,550; 6,812,551; 6,812,552; 6,812,553; 6,812,554; 6,812,555; 6,812,556; 6,812,557; 6,812,558; 6,812,559; 6,812,560; 6,812,561; 6,812,562; 6,812,563; 6,812,564; 6,812,565; 6,812,566; 6,812,567; 6,812,568; 6,812,569; 6,812,570; 6,812,571; 6,812,572; 6,812,573; 6,812,574; 6,812,575; 6,812,576; 6,812,577; 6,812,578; 6,812,579; 6,812,580; 6,812,581; 6,812,582; 6,812,583; 6,812,584; 6,812,585; 6,812,586; 6,812,587; 6,812,588; 6,812,589; 6,812,590; 6,812,591; 6,812,592; 6,812,593; 6,812,594; 6,812,595; 6,812,596; 6,812,597; 6,812,598; 6,812,599; 6,812,600; 6,812,601; 6,812,602; 6,812,603; 6,812,604; 6,812,605; 6,812,606; 6,812,607; 6,812,608; 6,812,609; 6,812,610; 6,812,611; 6,812,612; 6,812,613; 6,812,614; 6,812,615; 6,812,616; 6,812,617; 6,812,618; 6,812,619; 6,812,620; 6,812,621; 6,812,622; 6,812,623; 6,812,624; 6,812,625; 6,812,626; 6,812,627; 6,812,628; 6,812,629; 6,812,630; 6,812,631; 6,812,632; 6,812,633; 6,812,634; 6,812,635; 6,812,636; 6,812,637; 6,812,638; 6,812,639; 6,812,640; 6,812,641; 6,812,642; 6,812,643; 6,812,644; 6,812,645; 6,812,646; 6,812,647; 6,812,648; 6,812,649; 6,812,650; 6,812,651; 6,812,652; 6,812,653; 6,812,654; 6,812,655; 6,812,656; 6,812,657; 6,812,658; 6,812,659; 6,812,660; 6,812,661; 6,812,662; 6,812,663; 6,812,664; 6,812,665; 6,812,666; 6,812,667; 6,812,668; 6,812,669; 6,812,670; 6,812,671; 6,812,672; 6,812,673; 6,812,674; 6,812,675; 6,812,676; 6,812,677; 6,812,678; 6,812,679; 6,812,680; 6,812,681; 6,812,682; 6,812,683; 6,812,684; 6,812,685; 6,812,686; 6,812,687; 6,812,688; 6,812,689; 6,812,690; 6,812,691; 6,812,692; 6,812,693; 6,812,694; 6,812,695; 6,812,696; 6,812,697; 6,812,698; 6,812,699; 6,812,700; 6,812,701; 6,812,702; 6,812,703; 6,812,704; 6,812,705; 6,812,706; 6,812,707; 6,812,708; 6,812,709; 6,812,710; 6,812,711; 6,812,712; 6,812,713; 6,812,714; 6,812,715; 6,812,716; 6,812,717; 6,812,718; 6,812,719; 6,812,720; 6,812,721; 6,812,722; 6,812,723; 6,812,724; 6,812,725; 6,812,726; 6,812,727; 6,812,728; 6,812,729; 6,812,730; 6,812,731; 6,812,732; 6,812,733; 6,812,734; 6,812,735; 6,812,736; 6,812,737; 6,812,738; 6,812,739; 6,812,740; 6,812,741; 6,812,742; 6,812,743; 6,812,744; 6,812,745; 6,812,746; 6,812,747; 6,812,748; 6,812,749; 6,812,750; 6,812,751; 6,812,752; 6,812,753; 6,812,754; 6,812,755; 6,812,756; 6,812,757; 6,812,758; 6,812,759; 6,812,760; 6,812,761; 6,812,762; 6,812,763; 6,812,764; 6,812,765; 6,812,766; 6,812,767; 6,812,768; 6,812,769; 6,812,770; 6,812,771; 6,812,772; 6,812,773; 6,812,774; 6,812,775; 6,812,776; 6,812,777; 6,812,778; 6,812,779; 6,812,780; 6,812,781; 6,812,782; 6,812,783; 6,812,784; 6,812,785; 6,812,786; 6,812,787; 6,812,788; 6,812,789; 6,812,790; 6,812,791; 6,812,792; 6,812,793; 6,812,794; 6,812,795; 6,812,796; 6,812,797; 6,812,798; 6,812,799; 6,812,800; 6,812,801; 6,812,802; 6,812,803; 6,812,804; 6,812,805; 6,812,806; 6,812,807; 6,812,808; 6,812,809; 6,812,810; 6,812,811; 6,812,812; 6,812,813; 6,812,814; 6,812,815; 6,812,816; 6,812,817; 6,812,818; 6,812,819; 6,812,820; 6,812,821; 6,812,822; 6,812,823; 6,812,824; 6,812,825; 6,812,826; 6,812,827; 6,812,828; 6,812,829; 6,812,830; 6,812,831; 6,812,832; 6,812,833; 6,812,834; 6,812,835; 6,812,836; 6,812,837; 6,812,838; 6,812,839; 6,812,840; 6,812,841; 6,812,842; 6,812,843; 6,812,844; 6,812,845; 6,812,846; 6,812,847; 6,812,848; 6,812,849; 6,812,850; 6,812,851; 6,812,852; 6,812,853; 6,812,854; 6,812,855; 6,812,856; 6,812,857; 6,812,858; 6,812,859; 6,812,860; 6,812,861; 6,812,862; 6,812,863; 6,812,864; 6,812,865; 6,812,866; 6,812,867; 6,812,868; 6,812,869; 6,812,870; 6,812,871; 6,812,872; 6,812,873; 6,812,874; 6,812,875; 6,812,876; 6,812,877; 6,812,878; 6,812,879; 6,812,880; 6,812,881; 6,812,882; 6,812,883; 6,812,884; 6,812,885; 6,812,886; 6,812,887; 6,812,888; 6,812,889; 6,812,890; 6,812,891; 6,812,892; 6,812,893; 6,812,894; 6,812,895; 6,812,896; 6,812,897; 6,812,898; 6,812,899; 6,812,900; 6,812,901; 6,812,902; 6,812,903; 6,812,904; 6,812,905; 6,812,906; 6,812,907; 6,812,908; 6,812,909; 6,812,910; 6,812,911; 6,812,912; 6,812,913; 6,812,914; 6,812,915; 6,812,916; 6,812,917; 6,812,918; 6,812,919; 6,812,920; 6,812,921; 6,812,922; 6,812,923; 6,812,924; 6,812,925; 6,812,926; 6,812,927; 6,812,928; 6,812,929; 6,812,930; 6,812,931; 6,812,932; 6,812,933; 6,812,934; 6,812,935; 6,812,936; 6,812,937; 6,812,938; 6,812,939; 6,812,940; 6,812,941; 6,812,942; 6,812,943; 6,812,944; 6,812,945; 6,812,946; 6,812,947; 6,812,948; 6,812,949; 6,812,950; 6,812,951; 6,812,952; 6,812,953; 6,812,954; 6,812,955; 6,812,956; 6,812,957; 6,812,958; 6,812,959; 6,812,960; 6,812,961; 6,812,962; 6,812,963; 6,812,964; 6,812,965; 6,812,966; 6,812,967; 6,812,968; 6,812,969; 6,812,970; 6,812,971; 6,812,972; 6,812,973; 6,812,974; 6,812,975; 6,812,976; 6,812,977; 6,812,978; 6,812,979; 6,812,980; 6,812,981; 6,812,982; 6,812,983; 6,812,984; 6,812,985; 6,812,986; 6,812,987; 6,812,988; 6,812,989; 6,812,990; 6,812,991; 6,812,992; 6,812,993; 6,812,994; 6,812,995; 6,812,996; 6,812,997; 6,812,998; 6,812,999; 6,813,000.

MWS-L-4-17-C
STORMWATER BIOFILTRATION SYSTEM
STANDARD DETAIL

SITE SPECIFIC DATA	
PROJECT NAME	
PROJECT LOCATION	
STRUCTURE ID	
TREATMENT REQUIRED	FLOW BASED (GFS)
VOLUME BASED (CF)	
TREATMENT HGL AVAILABLE (FT)	
PEAK BYPASS REQUIRED (GFS) - IF APPLICABLE	
PIPE DATA	I.E. MATERIAL DIAMETER
INLET PIPE 1	
INLET PIPE 2	
OUTLET PIPE	
PRETREATMENT	BIOFILTRATION DISCHARGE
RIM ELEVATION	
SURFACE LOAD	PARKWAY OPEN PLANTER
FRAME & COVER	430" N/A 424"
WETLANDMEDIA VOLUME (CY)	5.41
WETLANDMEDIA DELIVERY METHOD	TBD
ORIFICE SIZE (DIA. INCHES)	42.05"
MAXIMUM PICK WEIGHT (LBS)	36000
NOTES:	

INSTALLATION NOTES

- CONTRACTOR TO PROVIDE ALL LABOR, EQUIPMENT, MATERIALS AND INCIDENTALS REQUIRED TO OFFLOAD AND INSTALL THE SYSTEM AND ADJUSTMENTS IN ACCORDANCE WITH THIS DRAWING AND THE MANUFACTURER'S SPECIFICATIONS, UNLESS OTHERWISE STATED IN MANUFACTURER'S CONTRACT.
- UNIT MUST BE INSTALLED ON LEVEL BASE. MANUFACTURER RECOMMENDS A MINIMUM 6" LEVEL ROCK BASE UNLESS SPECIFIED BY THE PROJECT ENGINEER. CONTRACTOR IS RESPONSIBLE TO VERIFY PROJECT ENGINEERS RECOMMENDED BASE SPECIFICATIONS.
- ALL PIPES MUST BE FLUSH WITH INSIDE SURFACE OF CONCRETE (PIPES CANNOT INTRUDE BEYOND FLUSH). INVERT OF OUTFLOW PIPE MUST BE FLUSH WITH DISCHARGE CHAMBER FLOOR. ALL GAPS AROUND PIPES SHALL BE SEALED WATER TIGHT WITH A NON-SHRINK GROUT PER MANUFACTURERS STANDARD CONNECTION DETAIL AND SHALL MEET OR EXCEED REGIONAL PIPE CONNECTION STANDARDS.
- CONTRACTOR TO SUPPLY AND INSTALL ALL EXTERNAL CONNECTING PIPES.
- CONTRACTOR RESPONSIBLE FOR INSTALLATION OF ALL RISERS, MANHOLES, AND HATCHES. CONTRACTOR TO GROUT ALL MANHOLES AND HATCHES TO MATCH FINISHED SURFACE UNLESS SPECIFIED OTHERWISE.
- DRIP OR SPRAY IRRIGATION REQUIRED ON ALL UNITS WITH VEGETATION.

GENERAL NOTES

- MANUFACTURER TO PROVIDE ALL MATERIALS UNLESS OTHERWISE NOTED.
- ALL DIMENSIONS, ELEVATIONS, SPECIFICATIONS AND CAPACITIES ARE SUBJECT TO CHANGE. FOR PROJECT SPECIFIC DRAWINGS DETAILING EXACT DIMENSIONS, WEIGHTS AND ACCESSORIES PLEASE CONTACT MANUFACTURER.

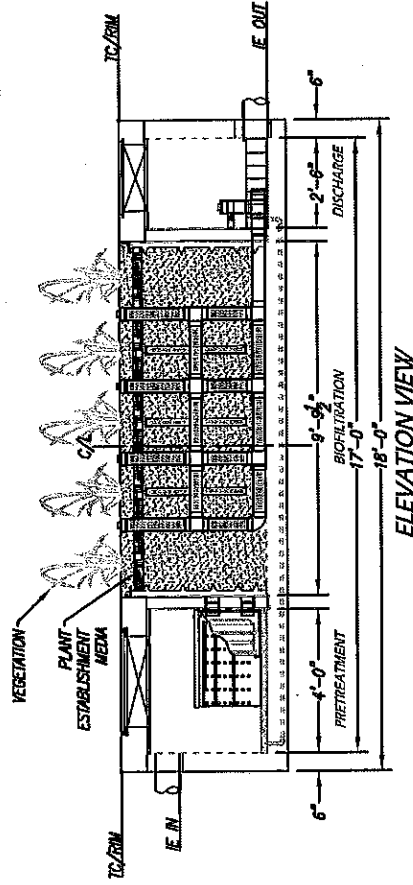
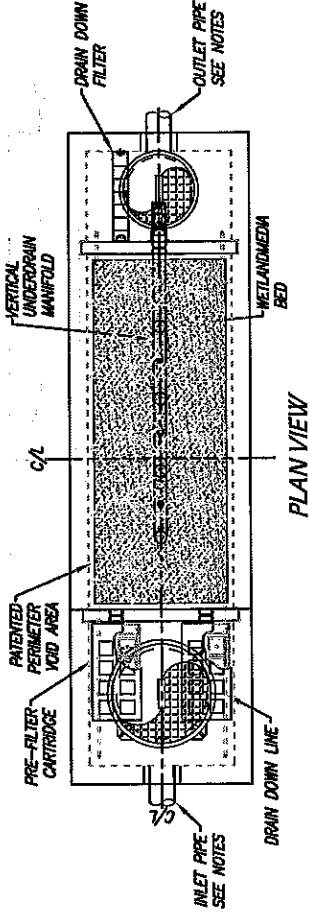
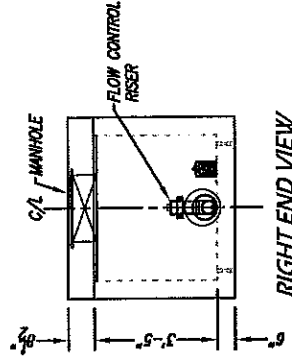
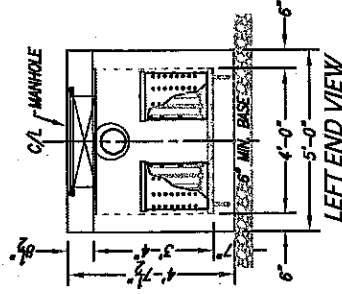

TREATMENT FLOW (GFS)	0.206
OPERATING HEAD (FT)	3.4
PRETREATMENT LOADING RATE (GPM/SF)	TBD
WETLAND MEDIA LOADING RATE (GPM/SF)	1.0

MWS-L-4-17-V
STORMWATER BIOFILTRATION SYSTEM
STANDARD DETAIL



PROPRIETARY AND CONFIDENTIAL:
 THE INFORMATION CONTAINED IN THIS DRAWING IS THE SOLE PROPERTY OF MODULAR WETLANDS SYSTEMS. ANY REPRODUCTION IN WHOLE OR IN PART WITHOUT THE WRITTEN PERMISSION OF MODULAR WETLANDS SYSTEMS IS PROHIBITED.

THE PRODUCT DESCRIBED MAY BE THE PROPERTY OF MODULAR WETLANDS SYSTEMS. ANY REPRODUCTION IN WHOLE OR IN PART WITHOUT THE WRITTEN PERMISSION OF MODULAR WETLANDS SYSTEMS IS PROHIBITED.

SITE SPECIFIC DATA	
PROJECT NAME	
PROJECT LOCATION	
STRUCTURE ID	
TREATMENT REQUIRED	FLOW BASED (CFS)
VOLUME BASED (CY)	
TREATMENT HGL AVAILABLE (FT)	
PEAK BYPASS REQUIRED (CFS) - IF APPLICABLE	
PIPE DATA	LE MATERIAL DIAMETER
INLET PIPE 1	
INLET PIPE 2	
OUTLET PIPE	
PRETREATMENT	BIOFILTRATION DISCHARGE
RIM ELEVATION	
SURFACE LOAD	PARKWAY
FRAME & COVER	#30" N/A #24" 6.52
WETLAND MEDIA VOLUME (CY)	
WETLAND MEDIA DELIVERY METHOD	TBD
ORIFICE SIZE (DIA. INCHES)	#2.20"
MAXIMUM PICK WEIGHT (LBS)	40000
NOTES:	

INSTALLATION NOTES

- CONTRACTOR TO PROVIDE ALL LABOR, EQUIPMENT, MATERIALS AND INCIDENTALS REQUIRED TO OFFLOAD AND INSTALL THE SYSTEM AND APPURTENANCES IN ACCORDANCE WITH THIS DRAWING AND THE MANUFACTURERS SPECIFICATIONS, UNLESS OTHERWISE STATED IN MANUFACTURERS CONTRACT.
- UNIT MUST BE INSTALLED ON LEVEL BASE. MANUFACTURER RECOMMENDS A MINIMUM 6" LEVEL ROCK BASE UNLESS SPECIFIED BY THE PROJECT ENGINEER. CONTRACTOR IS RESPONSIBLE TO VERIFY PROJECT ENGINEERS RECOMMENDED BASE SPECIFICATIONS.
- ALL PIPES MUST BE FLUSH WITH INSIDE SURFACE OF CONCRETE. (PIPES CANNOT INTRUDE BEYOND FLUSH). INVERT OF OUTFLOW PIPE MUST BE FLUSH WITH DISCHARGE CHAMBER FLOOR. ALL GAPS AROUND PIPES SHALL BE SEALED WATER TIGHT WITH A NON-SHRINK GROUT PER MANUFACTURERS STANDARD CONNECTION DETAIL AND SHALL MEET OR EXCEED REGIONAL PIPE CONNECTION STANDARDS.
- CONTRACTOR TO SUPPLY AND INSTALL ALL EXTERNAL CONNECTING PIPES.
- CONTRACTOR RESPONSIBLE FOR INSTALLATION OF ALL RISERS, MANHOLES AND HATCHES. CONTRACTOR TO GROUT ALL MANHOLES AND HATCHES TO MATCH FINISHED SURFACE UNLESS SPECIFIED OTHERWISE.
- GRIP OR SPRAY IRRIGATION REQUIRED ON ALL UNITS WITH VEGETATION.

GENERAL NOTES

- MANUFACTURER TO PROVIDE ALL MATERIALS UNLESS OTHERWISE NOTED.
- ALL DIMENSIONS, ELEVATIONS, SPECIFICATIONS AND CAPACITIES ARE SUBJECT TO CHANGE. FOR PRODUCT SPECIFIC DRAWINGS DETAILING EXACT DIMENSIONS, WEIGHTS AND ACCESSORIES PLEASE CONTACT MANUFACTURER.

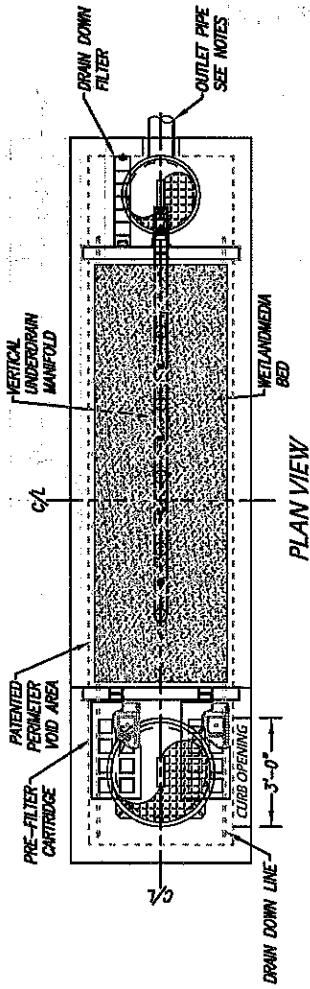

PLAN VIEW

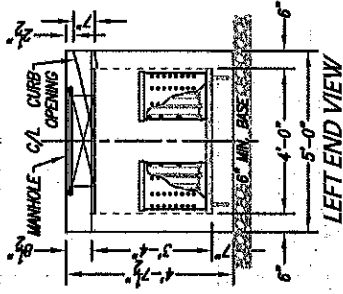

LEFT END VIEW

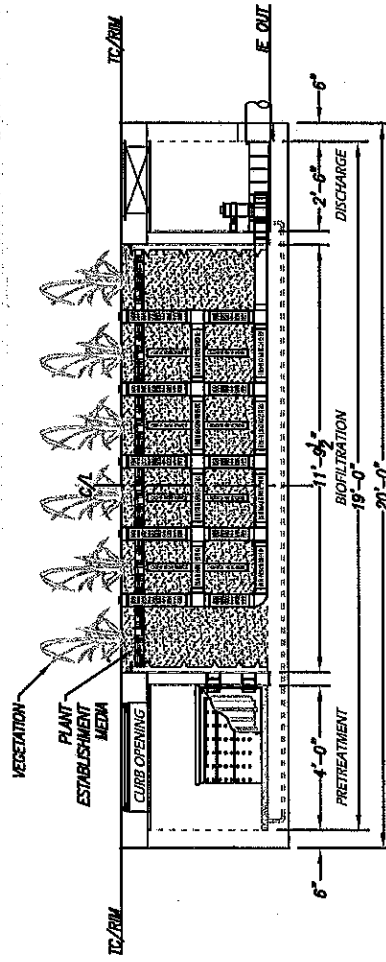

ELEVATION VIEW

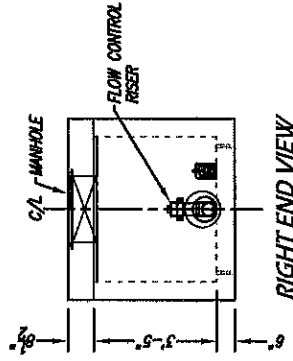

RIGHT END VIEW

TREATMENT FLOW (CFS)	0.237
OPERATING HEAD (FT)	3.4
PRETREATMENT LOADING RATE (GPM/SF)	TBD
WETLAND MEDIA LOADING RATE (GPM/SF)	1.0

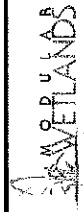

PROPRIETARY AND CONFIDENTIAL:
 THE INFORMATION CONTAINED IN THIS DRAWING IS THE SOLE PROPERTY OF ANGLAR WETLANDS SYSTEMS. ANY REPRODUCTION OR TRANSMISSION OF THIS DRAWING WITHOUT THE WRITTEN PERMISSION OF ANGLAR WETLANDS SYSTEMS IS PROHIBITED.

MWS-L-4-19-C
STORMWATER BIOFILTRATION SYSTEM
STANDARD DETAIL

SITE SPECIFIC DATA	
PROJECT NAME	
PROJECT LOCATION	
STRUCTURE ID	
TREATMENT REQUIRED	FLOW BASED (CFS)
VOLUME BASED (CF)	
TREATMENT H ₂ O AVAILABLE (FT)	
PEAK BYPASS REQUIRED (CFS) - IF APPLICABLE	
PIPE DATA	I.E. MATERIAL DIAMETER
INLET PIPE 1	
INLET PIPE 2	
OUTLET PIPE	
PRETREATMENT	BIOFILTRATION DISCHARGE
RM ELEVATION	
SURFACE LOAD	PARKWAY OPEN PLANTER PARKWAY
FRAME & COVER	430" N/A 424"
WETLAND MEDIA VOLUME (CY)	6.52
WETLAND MEDIA DELIVERY METHOD	TED
ORFICE SIZE (DIA. INCHES)	42.20"
MAXIMUM PICK WEIGHT (LBS)	40000
NOTES:	

INSTALLATION NOTES

- CONTRACTOR TO PROVIDE ALL LABOR, EQUIPMENT, MATERIALS AND INCIDENTALS REQUIRED TO O/FLOAD AND INSTALL THE SYSTEM AND APPURTENANCES IN ACCORDANCE WITH THIS DRAWING AND THE MANUFACTURERS SPECIFICATIONS, UNLESS OTHERWISE STATED IN MANUFACTURERS CONTRACT.
- UNIT MUST BE INSTALLED ON LEVEL BASE. MANUFACTURER RECOMMENDS A MINIMUM 6" LEVEL ROCK BASE UNLESS SPECIFIED BY THE PROJECT ENGINEER. CONTRACTOR IS RESPONSIBLE TO VERIFY PROJECT ENGINEERS RECOMMENDED BASE SPECIFICATIONS.
- ALL PIPES MUST BE FLUSH WITH INSIDE SURFACE OF CONCRETE (PIPES CANNOT INTRUDE BEYOND FLUSH). INVERT OF OUTFLOW PIPE MUST BE FLUSH WITH DISCHARGE CHAMBER FLOOR. ALL GAPS AROUND PIPES SHALL BE SEALED WATER TIGHT WITH A NON-SHRINK GROUT PER MANUFACTURERS STANDARD CONNECTION DETAIL AND SHALL MEET OR EXCEED REGIONAL PIPE CONNECTION STANDARDS.
- CONTRACTOR TO SUPPLY AND INSTALL ALL EXTERNAL CONNECTING PIPES.
- CONTRACTOR RESPONSIBLE FOR INSTALLATION OF ALL RISERS, MANHOLES, AND HATCHES. CONTRACTOR TO GROUT ALL MANHOLES AND HATCHES TO MATCH FINISHED SURFACE UNLESS SPECIFIED OTHERWISE.
- DRIP OR SPRAY IRRIGATION REQUIRED ON ALL UNITS WITH VEGETATION.

GENERAL NOTES

- MANUFACTURER TO PROVIDE ALL MATERIALS UNLESS OTHERWISE NOTED.
- ALL DIMENSIONS, ELEVATIONS, SPECIFICATIONS AND CAPACITIES ARE SUBJECT TO CHANGE. FOR PROJECT SPECIFIC DRAWINGS DETAILING EXACT DIMENSIONS, WEIGHTS AND ACCESSORIES PLEASE CONTACT MANUFACTURER.

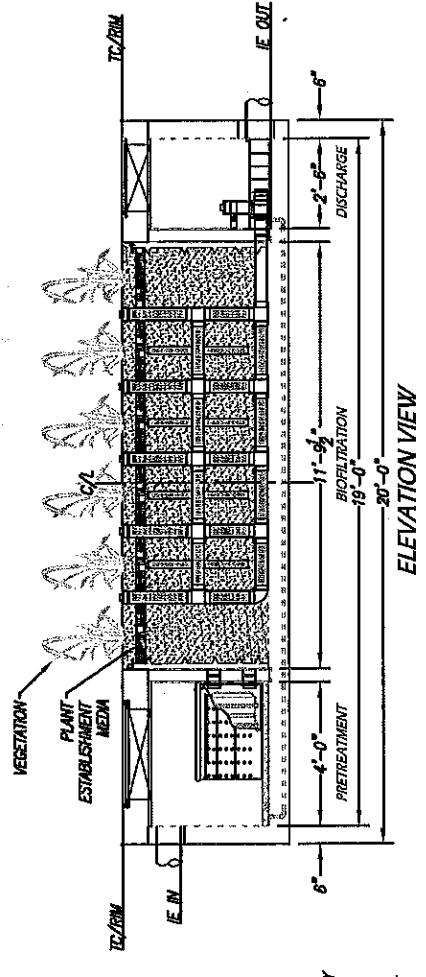
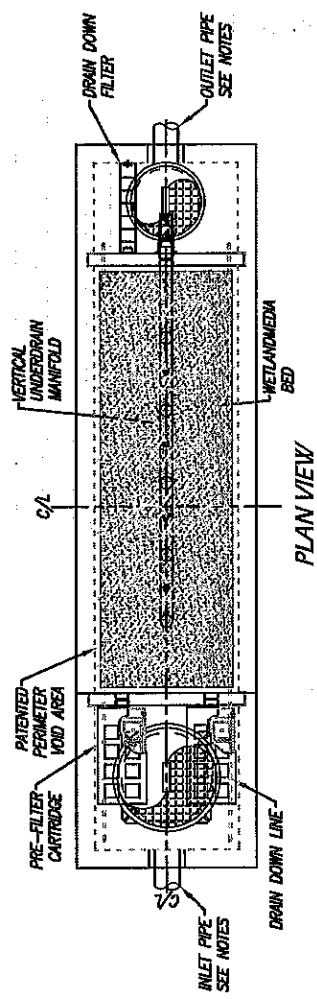
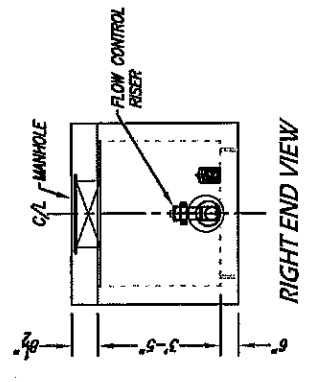
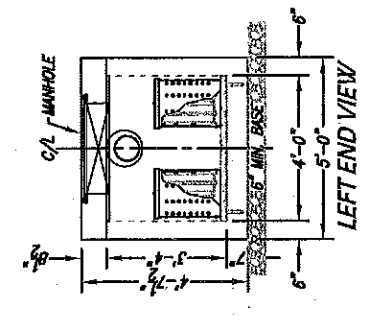

TREATMENT FLOW (CFS)	0.237
OPERATING HEAD (FT)	3.4
PRETREATMENT LOADING RATE (GPM/SF)	TBD
WETLAND MEDIA LOADING RATE (GPM/SF)	1.0

MWS-L-4-19-V
STORMWATER BIOFILTRATION SYSTEM
STANDARD DETAIL

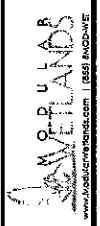

PROPRIETARY AND CONFIDENTIAL:
 THE INFORMATION CONTAINED IN THIS DRAWING IS THE SOLE PROPERTY OF M. O. P. U. L. A. N. D. S. ANY REPRODUCTION OR TRANSMISSION OF THIS DRAWING WITHOUT THE WRITTEN PERMISSION OF M. O. P. U. L. A. N. D. S. IS PROHIBITED.

SITE SPECIFIC DATA	
PROJECT NAME	
PROJECT LOCATION	
STRUCTURE ID	
TREATMENT REQUIRED	FLOW BASED (CFS)
VOLUME BASED (CF)	
TREATMENT HGL AVAILABLE (FT)	
PEAK BYPASS REQUIRED (CFS) - IF APPLICABLE	
PIPE DATA	I.E. MATERIAL DIAMETER
INLET PIPE 1	
INLET PIPE 2	
OUTLET PIPE	
RIM ELEVATION	PRETREATMENT BIOFILTRATION DISCHARGE
SURFACE LOAD	PARKWAY OPEN PLANTER
FRAME & COVER	Ø30" N/A Ø24"
WETLANDMEDIA VOLUME (CY)	7.65
WETLANDMEDIA DELIVERY METHOD	TBD
ORIFICE SIZE (DIA. INCHES)	Ø2.34"
MAXIMUM PICK WEIGHT (LBS)	43000
NOTES:	

INSTALLATION NOTES

- CONTRACTOR TO PROVIDE ALL LABOR, EQUIPMENT, MATERIALS AND INCIDENTALS REQUIRED TO OFFLOAD AND INSTALL THE SYSTEM AND APPURTENANCES IN ACCORDANCE WITH THIS DRAWING AND THE MANUFACTURERS SPECIFICATIONS, UNLESS OTHERWISE STATED IN MANUFACTURERS CONTRACT.
- UNIT MUST BE INSTALLED ON LEVEL BASE. MANUFACTURER RECOMMENDS A MINIMUM 6" LEVEL ROCK BASE UNLESS SPECIFIED BY THE PROJECT ENGINEER. CONTRACTOR IS RESPONSIBLE TO VERIFY ALL PIPES MUST BE FLUSH WITH INSIDE SURFACE OF CONCRETE (PIPES CANNOT INTRUDE BEYOND FLUSH). INVERT OF OUTFLOW PIPE MUST BE FLUSH WITH DISCHARGE CHAMBER FLOOR. ALL GAPS AROUND PIPES SHALL BE SEALED WATER TIGHT WITH A NON-SHRINK GROUT PER MANUFACTURERS STANDARD CONNECTION DETAIL AND SHALL MEET OR EXCEED REGIONAL PIPE CONNECTION STANDARDS.
- CONTRACTOR TO SUPPLY AND INSTALL ALL EXTERNAL CONNECTING PIPES.
- CONTRACTOR RESPONSIBLE FOR INSTALLATION OF ALL RISERS, MANHOLES, AND HATCHES. CONTRACTOR TO GROUT ALL MANHOLES AND HATCHES TO MATCH FINISHED SURFACE UNLESS SPECIFIED OTHERWISE.
- DRIP OR SPRAY IRRIGATION REQUIRED ON ALL UNITS WITH VEGETATION.

GENERAL NOTES

- MANUFACTURER TO PROVIDE ALL MATERIALS UNLESS OTHERWISE NOTED.
- ALL DIMENSIONS, ELEVATIONS, SPECIFICATIONS AND CAPACITIES ARE SUBJECT TO CHANGE. FOR PROJECT SPECIFIC DRAWINGS DETAILING EXACT DIMENSIONS, HEIGHTS AND ACCESSORIES PLEASE CONTACT MANUFACTURER.

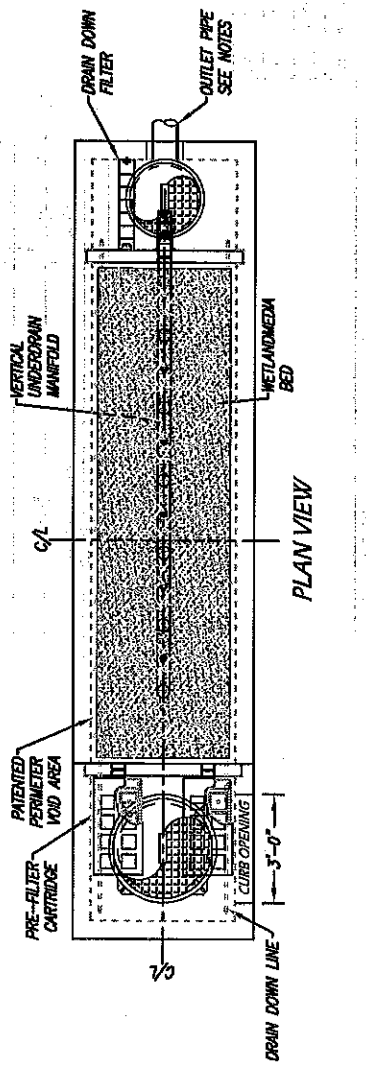

PLAN VIEW

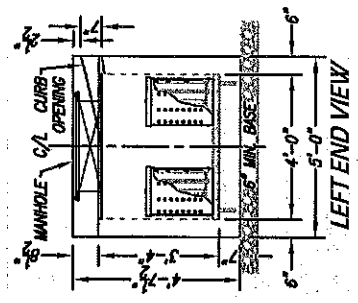

LEFT END VIEW

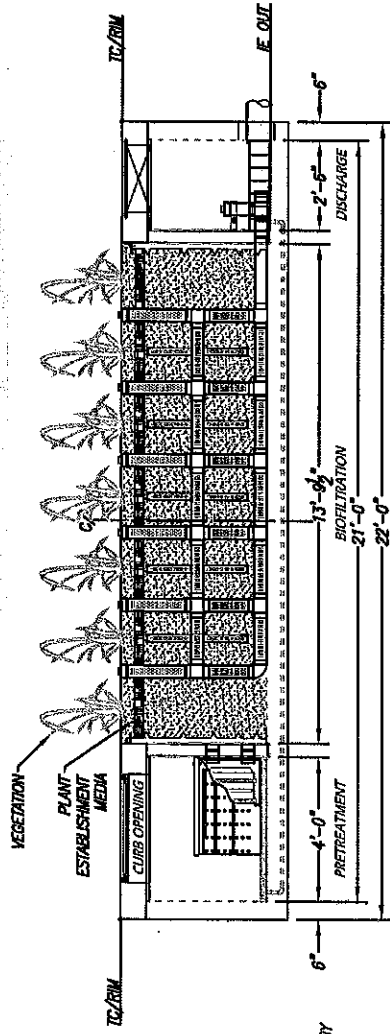

ELEVATION VIEW

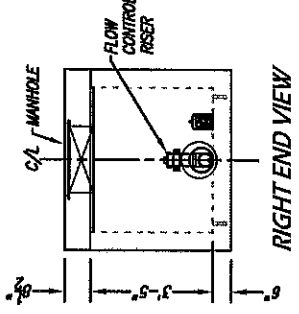

RIGHT END VIEW

TREATMENT FLOW (CFS)	0.268
OPERATING HEAD (FT)	3.4
PRETREATMENT LOADING RATE (GPM/SF)	TBD
WETLAND MEDIA LOADING RATE (GPM/SF)	1.0

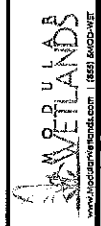

PROPRIETARY AND CONFIDENTIAL
 THE INFORMATION CONTAINED IN THIS DRAWING IS THE SOLE PROPERTY OF MWS METLANDS SYSTEMS. ANY REPRODUCTION IN ANY FORM OR BY ANY MEANS WITHOUT PERMISSION OF MWS METLANDS SYSTEMS IS PROHIBITED.

THIS PROJECT DESIGN MAY BE REPRODUCED BY ONE OR MORE OF THE FOLLOWING US PATENTS: 7,482,382; 7,474,382; 7,674,478. SUBSTITUTES REQUIRED UNDER PATENTS OR OTHER PATENTS BEING PENDING OR OTHER PATENTS BEING

MWS METLANDS SYSTEMS
 www.mwsdesign.com (866) 640-0457

MWS-L-4-21-C
 STORMWATER BIOFILTRATION SYSTEM
 STANDARD DETAIL

SITE SPECIFIC DATA			
PROJECT NAME			
PROJECT LOCATION			
STRUCTURE ID			
TREATMENT REQUIRED	FLOW BASED (CFS)		
VOLUME BASED (CF)			
TREATMENT HGL AVAILABLE (FT)			
PEAK BYPASS REQUIRED (CFS) - IF APPLICABLE			
PIPE DATA	I.E.	MATERIAL	DIAMETER
INLET PIPE 1			
INLET PIPE 2			
OUTLET PIPE			
PRETREATMENT		BIOFILTRATION	DISCHARGE
RIM ELEVATION			
SURFACE LOAD	PARKWAY	OPEN PLANER	PARKWAY
FRAME & COVER	#30"	N/A	#24"
WETLANDMEDIA VOLUME (CY)			7.63
WETLANDMEDIA DELIVERY METHOD			TBD
ORIFICE SIZE (DIA. INCHES)			#2.34"
MAXIMUM PICK WEIGHT (LBS)			43000
NOTES:			

INSTALLATION NOTES

- CONTRACTOR TO PROVIDE ALL LABOR, EQUIPMENT, MATERIALS AND INCIDENTALS REQUIRED TO OFFLOAD AND INSTALL THE SYSTEM AND APPURTENANCES IN ACCORDANCE WITH THIS DRAWING AND THE MANUFACTURERS SPECIFICATIONS, UNLESS OTHERWISE STATED IN MANUFACTURERS CONTRACT.
- UNIT MUST BE INSTALLED ON LEVEL BASE. MANUFACTURER RECOMMENDS A MINIMUM 6" LEVEL ROCK BASE UNLESS SPECIFIED BY THE PROJECT ENGINEER. CONTRACTOR IS RESPONSIBLE TO VERIFY PROJECT ENGINEERS RECOMMENDED BASE SPECIFICATIONS.
- ALL PIPES MUST BE FLUSH WITH INSIDE SURFACE OF CONCRETE. (PIPES CANNOT INTRUDE BEYOND FLUSH). INVERT OF OUTFLOW PIPE MUST BE FLUSH WITH DISCHARGE CHAMBER FLOOR. ALL GAPS AROUND PIPES SHALL BE SEALED WATER TIGHT WITH A NON-SHRINK GROUT PER MANUFACTURERS STANDARD CONNECTION DETAIL AND SHALL MEET OR EXCEED REGIONAL PIPE CONNECTION STANDARDS.
- CONTRACTOR TO SUPPLY AND INSTALL ALL EXTERNAL CONNECTING PIPES.
- CONTRACTOR RESPONSIBLE FOR INSTALLATION OF ALL RISERS, MANHOLES, AND HATCHES. CONTRACTOR TO GROUT ALL MANHOLES AND HATCHES TO MATCH FINISHED SURFACE UNLESS SPECIFIED OTHERWISE.
- DRIP OR SPRAY IRRIGATION REQUIRED ON ALL UNITS WITH VEGETATION.

GENERAL NOTES

- MANUFACTURER TO PROVIDE ALL MATERIALS UNLESS OTHERWISE NOTED.
- ALL DIMENSIONS, ELEVATIONS, SPECIFICATIONS AND CAPACITIES ARE SUBJECT TO CHANGE. FOR PROJECT SPECIFIC DRAWINGS DETAILING EXACT DIMENSIONS, WEIGHTS AND ACCESSORIES PLEASE CONTACT MANUFACTURER.

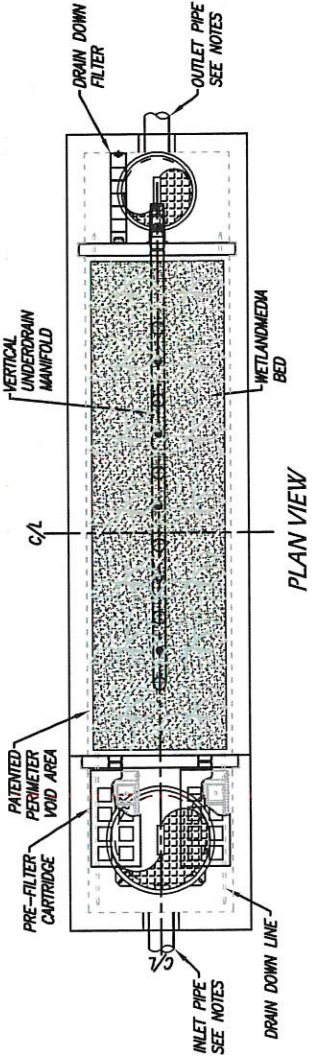
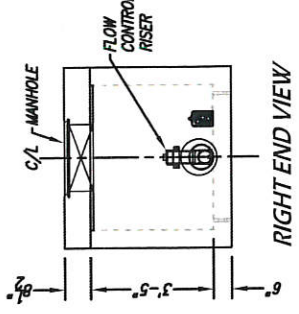
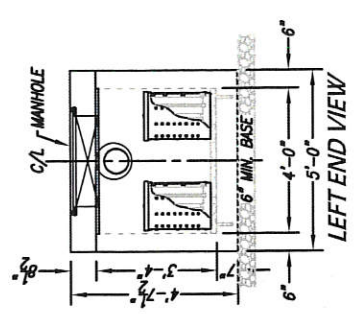

PLAN VIEW

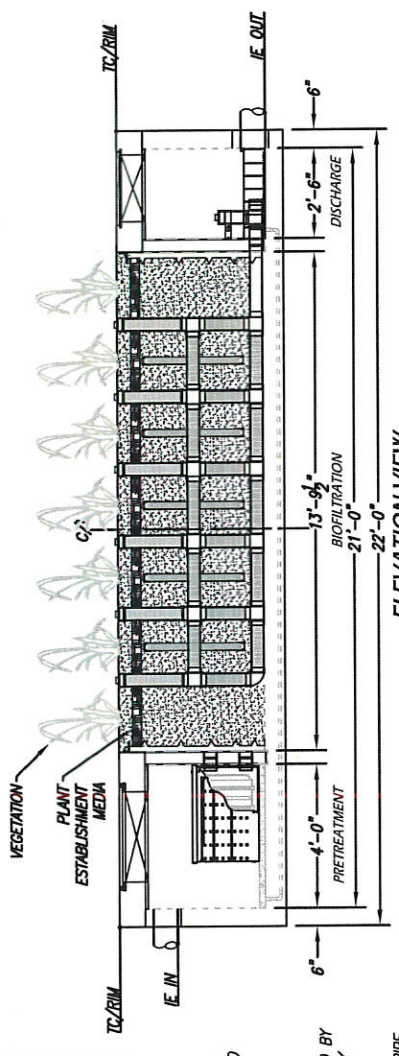

ELEVATION VIEW

TREATMENT FLOW (CFS)	0.268
OPERATING HEAD (FT)	3.4
PRETREATMENT LOADING RATE (GPM/SF)	TBD
WETLAND MEDIA LOADING RATE (GPM/SF)	1.0

MWS-L-4-21-V
STORMWATER BIOFILTRATION SYSTEM
STANDARD DETAIL



PROPRIETARY AND CONFIDENTIAL:
 THE INFORMATION CONTAINED IN THIS DRAWING IS THE SOLE PROPERTY OF MODULAR WETLANDS SYSTEMS. ANY REPRODUCTION OR TRANSMISSION OF THIS DRAWING WITHOUT THE WRITTEN PERMISSION OF MODULAR WETLANDS SYSTEMS IS PROHIBITED.

THE PRODUCT DESCRIBED MAY BE PROTECTED BY ONE OR MORE OF THE FOLLOWING US PATENTS:
 7,425,952; 7,470,952; 7,674,374;
 8,330,016; RELATED FOREIGN PATENTS OR OTHER PENDING PENDING

SITE SPECIFIC DATA	
PROJECT NAME	
PROJECT LOCATION	
STRUCTURE ID	
TREATMENT REQUIRED	
VOLUME BASED (CF)	FLOW BASED (CFS)
TREATMENT HGL AVAILABLE (FT)	
PEAK BYPASS REQUIRED (CFS) - IF APPLICABLE	
PIPE DATA I.E. MATERIAL	DIAMETER
INLET PIPE 1	
INLET PIPE 2	
OUTLET PIPE	
RIM ELEVATION	BIOFILTRATION
SURFACE LOAD	PARKWAY
FRAME & COVER	#30" N/A
WETLAND MEDIA VOLUME (CY)	4.75
WETLAND MEDIA DELIVERY METHOD	TBD
ORIFICE SIZE (DIA. INCHES)	#1.73"
MAXIMUM PICK WEIGHT (LBS)	TBD
NOTES	

INSTALLATION NOTES

- CONTRACTOR TO PROVIDE ALL LABOR, EQUIPMENT, MATERIALS AND INCIDENTALS REQUIRED TO OFFLOAD AND INSTALL THE SYSTEM AND APPURTENANCES IN ACCORDANCE WITH THIS DRAWING AND THE MANUFACTURERS SPECIFICATIONS, UNLESS OTHERWISE STATED IN MANUFACTURERS CONTRACT.
- UNIT MUST BE INSTALLED ON LEVEL BASE. MANUFACTURER RECOMMENDS A MINIMUM 6" LEVEL ROCK BASE UNLESS SPECIFIED BY THE PROJECT ENGINEER. CONTRACTOR IS RESPONSIBLE TO VERIFY ALL PIPES MUST BE FLUSH WITH INSIDE SURFACE OF CONCRETE. (PIPES CANNOT INTRUDE BEYOND FLUSH). INVERT OF OUTFLOW PIPE MUST BE FLUSH WITH DISCHARGE CHAMBER FLOOR. ALL GAPS AROUND PIPES SHALL BE SEALED WATER TIGHT WITH A NON-SHRINK GROUT PER MANUFACTURERS STANDARD CONNECTION DETAIL AND SHALL MEET OR EXCEED REGIONAL PIPE CONNECTION STANDARDS.
- CONTRACTOR TO SUPPLY AND INSTALL ALL EXTERNAL CONNECTING PIPES.
- CONTRACTOR RESPONSIBLE FOR INSTALLATION OF ALL RISERS, MANHOLES, AND HATCHES. CONTRACTOR TO GROUT ALL MANHOLES AND HATCHES TO MATCH FINISHED SURFACE UNLESS SPECIFIED OTHERWISE.
- DRIP OR SPRAY IRRIGATION REQUIRED ON ALL UNITS WITH VEGETATION.

GENERAL NOTES

- MANUFACTURER TO PROVIDE ALL MATERIALS UNLESS OTHERWISE NOTED.
- ALL DIMENSIONS, ELEVATIONS, SPECIFICATIONS AND CAPACITIES ARE SUBJECT TO CHANGE FOR PROJECT SPECIFIC DRAWINGS DETAILING EXACT DIMENSIONS, WEIGHTS AND ACCESSORIES PLEASE CONTACT MANUFACTURER.

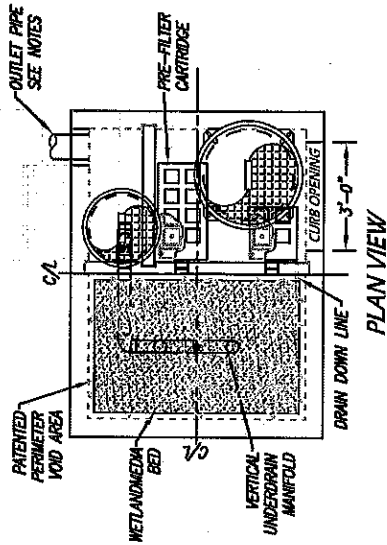

PLAN VIEW

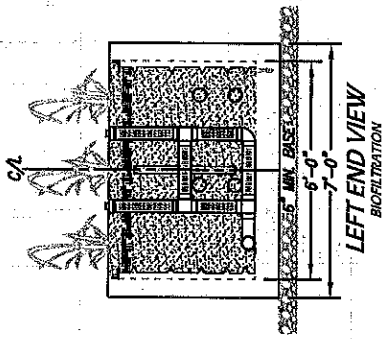

LEFT END VIEW
BIOFILTRATION

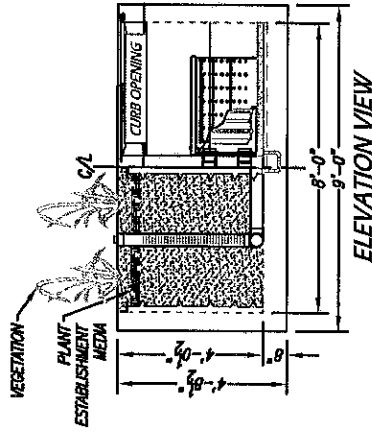

ELEVATION VIEW

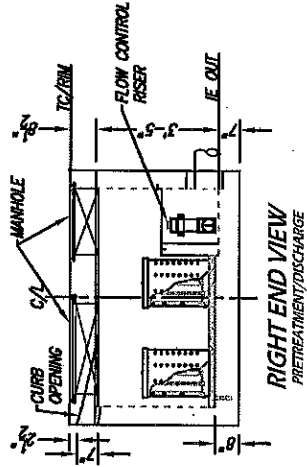

RIGHT END VIEW
PRETREATMENT/DISCHARGE

TREATMENT FLOW (CFS)	0.147
OPERATING HEAD (FT)	3.4
PRETREATMENT LOADING RATE (GPM/SF)	TBD
WETLAND MEDIA LOADING RATE (GPM/SF)	1.0



PROPRIETARY AND CONFIDENTIAL
THE INFORMATION CONTAINED IN THIS DRAWING IS THE SOLE PROPERTY OF MODULAR WETLANDS SYSTEMS. ANY REPRODUCTION OR TRANSMISSION OF ANY INFORMATION CONTAINED HEREIN WITHOUT THE WRITTEN PERMISSION OF MODULAR WETLANDS SYSTEMS IS PROHIBITED.

THE PRODUCT DESCRIBED MAY BE PROVIDED BY ONE OR MORE OF THE FOLLOWING US PATENTS: 2,462,002; 7,470,825; 7,876,474; 7,876,475; 7,876,476; 7,876,477; 7,876,478; 7,876,479; 7,876,480; 7,876,481; 7,876,482; 7,876,483; 7,876,484; 7,876,485; 7,876,486; 7,876,487; 7,876,488; 7,876,489; 7,876,490; 7,876,491; 7,876,492; 7,876,493; 7,876,494; 7,876,495; 7,876,496; 7,876,497; 7,876,498; 7,876,499; 7,876,500; 7,876,501; 7,876,502; 7,876,503; 7,876,504; 7,876,505; 7,876,506; 7,876,507; 7,876,508; 7,876,509; 7,876,510; 7,876,511; 7,876,512; 7,876,513; 7,876,514; 7,876,515; 7,876,516; 7,876,517; 7,876,518; 7,876,519; 7,876,520; 7,876,521; 7,876,522; 7,876,523; 7,876,524; 7,876,525; 7,876,526; 7,876,527; 7,876,528; 7,876,529; 7,876,530; 7,876,531; 7,876,532; 7,876,533; 7,876,534; 7,876,535; 7,876,536; 7,876,537; 7,876,538; 7,876,539; 7,876,540; 7,876,541; 7,876,542; 7,876,543; 7,876,544; 7,876,545; 7,876,546; 7,876,547; 7,876,548; 7,876,549; 7,876,550; 7,876,551; 7,876,552; 7,876,553; 7,876,554; 7,876,555; 7,876,556; 7,876,557; 7,876,558; 7,876,559; 7,876,560; 7,876,561; 7,876,562; 7,876,563; 7,876,564; 7,876,565; 7,876,566; 7,876,567; 7,876,568; 7,876,569; 7,876,570; 7,876,571; 7,876,572; 7,876,573; 7,876,574; 7,876,575; 7,876,576; 7,876,577; 7,876,578; 7,876,579; 7,876,580; 7,876,581; 7,876,582; 7,876,583; 7,876,584; 7,876,585; 7,876,586; 7,876,587; 7,876,588; 7,876,589; 7,876,590; 7,876,591; 7,876,592; 7,876,593; 7,876,594; 7,876,595; 7,876,596; 7,876,597; 7,876,598; 7,876,599; 7,876,600; 7,876,601; 7,876,602; 7,876,603; 7,876,604; 7,876,605; 7,876,606; 7,876,607; 7,876,608; 7,876,609; 7,876,610; 7,876,611; 7,876,612; 7,876,613; 7,876,614; 7,876,615; 7,876,616; 7,876,617; 7,876,618; 7,876,619; 7,876,620; 7,876,621; 7,876,622; 7,876,623; 7,876,624; 7,876,625; 7,876,626; 7,876,627; 7,876,628; 7,876,629; 7,876,630; 7,876,631; 7,876,632; 7,876,633; 7,876,634; 7,876,635; 7,876,636; 7,876,637; 7,876,638; 7,876,639; 7,876,640; 7,876,641; 7,876,642; 7,876,643; 7,876,644; 7,876,645; 7,876,646; 7,876,647; 7,876,648; 7,876,649; 7,876,650; 7,876,651; 7,876,652; 7,876,653; 7,876,654; 7,876,655; 7,876,656; 7,876,657; 7,876,658; 7,876,659; 7,876,660; 7,876,661; 7,876,662; 7,876,663; 7,876,664; 7,876,665; 7,876,666; 7,876,667; 7,876,668; 7,876,669; 7,876,670; 7,876,671; 7,876,672; 7,876,673; 7,876,674; 7,876,675; 7,876,676; 7,876,677; 7,876,678; 7,876,679; 7,876,680; 7,876,681; 7,876,682; 7,876,683; 7,876,684; 7,876,685; 7,876,686; 7,876,687; 7,876,688; 7,876,689; 7,876,690; 7,876,691; 7,876,692; 7,876,693; 7,876,694; 7,876,695; 7,876,696; 7,876,697; 7,876,698; 7,876,699; 7,876,700; 7,876,701; 7,876,702; 7,876,703; 7,876,704; 7,876,705; 7,876,706; 7,876,707; 7,876,708; 7,876,709; 7,876,710; 7,876,711; 7,876,712; 7,876,713; 7,876,714; 7,876,715; 7,876,716; 7,876,717; 7,876,718; 7,876,719; 7,876,720; 7,876,721; 7,876,722; 7,876,723; 7,876,724; 7,876,725; 7,876,726; 7,876,727; 7,876,728; 7,876,729; 7,876,730; 7,876,731; 7,876,732; 7,876,733; 7,876,734; 7,876,735; 7,876,736; 7,876,737; 7,876,738; 7,876,739; 7,876,740; 7,876,741; 7,876,742; 7,876,743; 7,876,744; 7,876,745; 7,876,746; 7,876,747; 7,876,748; 7,876,749; 7,876,750; 7,876,751; 7,876,752; 7,876,753; 7,876,754; 7,876,755; 7,876,756; 7,876,757; 7,876,758; 7,876,759; 7,876,760; 7,876,761; 7,876,762; 7,876,763; 7,876,764; 7,876,765; 7,876,766; 7,876,767; 7,876,768; 7,876,769; 7,876,770; 7,876,771; 7,876,772; 7,876,773; 7,876,774; 7,876,775; 7,876,776; 7,876,777; 7,876,778; 7,876,779; 7,876,780; 7,876,781; 7,876,782; 7,876,783; 7,876,784; 7,876,785; 7,876,786; 7,876,787; 7,876,788; 7,876,789; 7,876,790; 7,876,791; 7,876,792; 7,876,793; 7,876,794; 7,876,795; 7,876,796; 7,876,797; 7,876,798; 7,876,799; 7,876,800; 7,876,801; 7,876,802; 7,876,803; 7,876,804; 7,876,805; 7,876,806; 7,876,807; 7,876,808; 7,876,809; 7,876,810; 7,876,811; 7,876,812; 7,876,813; 7,876,814; 7,876,815; 7,876,816; 7,876,817; 7,876,818; 7,876,819; 7,876,820; 7,876,821; 7,876,822; 7,876,823; 7,876,824; 7,876,825; 7,876,826; 7,876,827; 7,876,828; 7,876,829; 7,876,830; 7,876,831; 7,876,832; 7,876,833; 7,876,834; 7,876,835; 7,876,836; 7,876,837; 7,876,838; 7,876,839; 7,876,840; 7,876,841; 7,876,842; 7,876,843; 7,876,844; 7,876,845; 7,876,846; 7,876,847; 7,876,848; 7,876,849; 7,876,850; 7,876,851; 7,876,852; 7,876,853; 7,876,854; 7,876,855; 7,876,856; 7,876,857; 7,876,858; 7,876,859; 7,876,860; 7,876,861; 7,876,862; 7,876,863; 7,876,864; 7,876,865; 7,876,866; 7,876,867; 7,876,868; 7,876,869; 7,876,870; 7,876,871; 7,876,872; 7,876,873; 7,876,874; 7,876,875; 7,876,876; 7,876,877; 7,876,878; 7,876,879; 7,876,880; 7,876,881; 7,876,882; 7,876,883; 7,876,884; 7,876,885; 7,876,886; 7,876,887; 7,876,888; 7,876,889; 7,876,890; 7,876,891; 7,876,892; 7,876,893; 7,876,894; 7,876,895; 7,876,896; 7,876,897; 7,876,898; 7,876,899; 7,876,900; 7,876,901; 7,876,902; 7,876,903; 7,876,904; 7,876,905; 7,876,906; 7,876,907; 7,876,908; 7,876,909; 7,876,910; 7,876,911; 7,876,912; 7,876,913; 7,876,914; 7,876,915; 7,876,916; 7,876,917; 7,876,918; 7,876,919; 7,876,920; 7,876,921; 7,876,922; 7,876,923; 7,876,924; 7,876,925; 7,876,926; 7,876,927; 7,876,928; 7,876,929; 7,876,930; 7,876,931; 7,876,932; 7,876,933; 7,876,934; 7,876,935; 7,876,936; 7,876,937; 7,876,938; 7,876,939; 7,876,940; 7,876,941; 7,876,942; 7,876,943; 7,876,944; 7,876,945; 7,876,946; 7,876,947; 7,876,948; 7,876,949; 7,876,950; 7,876,951; 7,876,952; 7,876,953; 7,876,954; 7,876,955; 7,876,956; 7,876,957; 7,876,958; 7,876,959; 7,876,960; 7,876,961; 7,876,962; 7,876,963; 7,876,964; 7,876,965; 7,876,966; 7,876,967; 7,876,968; 7,876,969; 7,876,970; 7,876,971; 7,876,972; 7,876,973; 7,876,974; 7,876,975; 7,876,976; 7,876,977; 7,876,978; 7,876,979; 7,876,980; 7,876,981; 7,876,982; 7,876,983; 7,876,984; 7,876,985; 7,876,986; 7,876,987; 7,876,988; 7,876,989; 7,876,990; 7,876,991; 7,876,992; 7,876,993; 7,876,994; 7,876,995; 7,876,996; 7,876,997; 7,876,998; 7,876,999; 7,877,000.

SITE SPECIFIC DATA	
PROJECT NAME	
PROJECT LOCATION	
STRUCTURE ID	
TREATMENT REQUIRED	FLOW BASED (CFS)
VOLUME BASED (CF)	
TREATMENT HGL AVAILABLE (FT)	
PEAK BYPASS REQUIRED (CFS) - IF APPLICABLE	
PIPE DATA	I.E. MATERIAL DIAMETER
INLET PIPE 1	
INLET PIPE 2	
OUTLET PIPE	
RIM ELEVATION	
SURFACE LOAD	PARKWAY OPEN PLANTER PARKWAY
FRAME & COVER	430" N/A 824"
WETLANDMEDIA VOLUME (CY)	4.75
WETLANDMEDIA DELIVERY METHOD	TBD
ORIFICE SIZE (DIA. INCHES)	#1.73"
MAXIMUM PICK WEIGHT (LBS)	TBD
NOTES:	

INSTALLATION NOTES

- CONTRACTOR TO PROVIDE ALL LABOR, EQUIPMENT, MATERIALS AND INCIDENTALS REQUIRED TO OFFLOAD AND INSTALL THE SYSTEM AND APPURTENANCES IN ACCORDANCE WITH THIS DRAWING AND THE MANUFACTURERS SPECIFICATIONS, UNLESS OTHERWISE STATED IN MANUFACTURERS CONTRACT.
- UNIT MUST BE INSTALLED ON LEVEL BASE. MANUFACTURER RECOMMENDS A MINIMUM 6" LEVEL ROCK BASE UNLESS SPECIFIED BY THE PROJECT ENGINEER. CONTRACTOR IS RESPONSIBLE TO VERIFY PROJECT ENGINEERS RECOMMENDED BASE SPECIFICATIONS.
- ALL PIPES MUST BE FLUSH WITH INSIDE SURFACE OF CONCRETE. (PIPES CANNOT INTRODUCE BEYOND FLUSH). INVERT OF OUTFLOW PIPE MUST BE FLUSH WITH DISCHARGE CHAMBER FLOOR. ALL CAPS AROUND PIPES SHALL BE SEALED WATER TIGHT WITH A NON-SHRINK GROUT PER MANUFACTURERS STANDARD CONNECTION DETAIL AND SHALL MEET OR EXCEED REGIONAL PIPE CONNECTION STANDARDS.
- CONTRACTOR TO SUPPLY AND INSTALL ALL EXTERNAL CONNECTING PIPES.
- CONTRACTOR RESPONSIBLE FOR INSTALLATION OF ALL RISERS, MANHOLES, AND HATCHES. CONTRACTOR TO GROUT ALL MANHOLES AND HATCHES TO MATCH FINISHED SURFACE UNLESS SPECIFIED OTHERWISE.
- DRIP OR SPRAY IRRIGATION REQUIRED ON ALL UNITS WITH VEGETATION.

GENERAL NOTES

- MANUFACTURER TO PROVIDE ALL MATERIALS UNLESS OTHERWISE NOTED.
- ALL DIMENSIONS, ELEVATIONS, SPECIFICATIONS AND CAPACITIES ARE SUBJECT TO CHANGE. FOR PROJECT SPECIFIC DRAWINGS DETAILING EXACT DIMENSIONS, WEIGHTS AND ACCESSORIES PLEASE CONTACT MANUFACTURER.

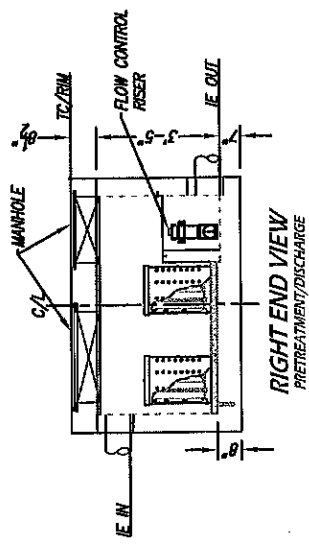
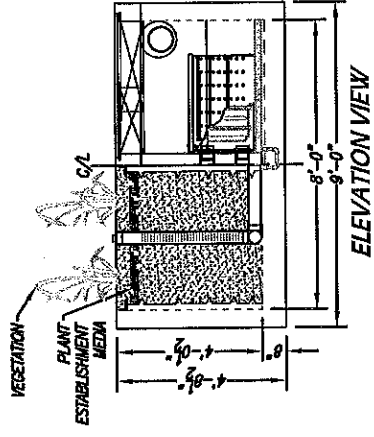
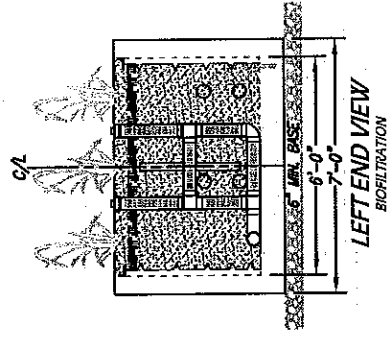
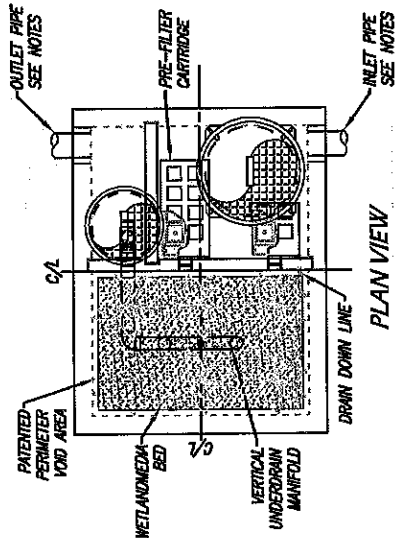

TREATMENT FLOW (CFS)	0.147
OPERATING HEAD (FT)	3.4
PRETREATMENT LOADING RATE (GPM/SF)	TBD
WETLAND MEDIA LOADING RATE (GPM/SF)	1.0

MWS-L-6-8-V
STORMWATER BIOFILTRATION SYSTEM
STANDARD DETAIL

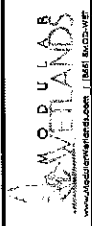

THE PRODUCT DESCRIBED AND THE INFORMATION CONTAINED IN THIS DRAWING IS THE SOLE PROPERTY OF MWS WETLANDS SYSTEMS. ANY REPRODUCTION IN PART OR AS A WHOLE WITHOUT THE WRITTEN PERMISSION OF MWS WETLANDS SYSTEMS IS PROHIBITED.

PROPRIETARY AND CONFIDENTIAL:
 THE INFORMATION CONTAINED IN THIS DRAWING IS THE SOLE PROPERTY OF MWS WETLANDS SYSTEMS. ANY REPRODUCTION IN PART OR AS A WHOLE WITHOUT THE WRITTEN PERMISSION OF MWS WETLANDS SYSTEMS IS PROHIBITED.

SITE SPECIFIC DATA	
PROJECT NAME	
PROJECT LOCATION	
STRUCTURE ID	TREATMENT REQUIRED
VOLUME BASED (CF)	FLOW BASED (CFS)
TREATMENT HQL AVAILABLE (FT)	
PEAK BYPASS REQUIRED (CFS) - IF APPLICABLE	
PIPE DATA	IE MATERIAL DIAMETER
INLET PIPE 1	
INLET PIPE 2	
OUTLET PIPE	
PRETREATMENT	BIOFILTRATION DISCHARGE
RIM ELEVATION	
SURFACE LOAD	PARKWAY OPEN PLANTER PARKWAY
FRAME & COVER	430" N/A
WETLAND MEDIA VOLUME (CY)	4.84
WETLAND MEDIA DELIVERY METHOD	TBD
ORIFICE SIZE (DIA. INCHES)	42.16"
MAXIMUM PICK WEIGHT (LBS)	TBD
NOTES	

INSTALLATION NOTES

- CONTRACTOR TO PROVIDE ALL LABOR, EQUIPMENT, MATERIALS AND INCIDENTALS REQUIRED TO OFFLOAD AND INSTALL THE SYSTEM AND APPOINTMENTS IN ACCORDANCE WITH THIS DRAWING AND THE MANUFACTURERS SPECIFICATIONS, UNLESS OTHERWISE STATED IN MANUFACTURERS CONTRACT.
- UNIT MUST BE INSTALLED ON LEVEL BASE. MANUFACTURER RECOMMENDS A MINIMUM 6" LEVEL ROCK BASE UNLESS SPECIFIED BY THE PROJECT ENGINEER. CONTRACTOR IS RESPONSIBLE TO VERIFY PROJECT ENGINEERS RECOMMENDED BASE SPECIFICATIONS.
- ALL PIPES MUST BE FLUSH WITH INSIDE SURFACE OF CONCRETE (PIPES CANNOT INTRUDE BEYOND FLUSH). INVERT OF OUTFLOW PIPE MUST BE FLUSH WITH DISCHARGE CHAMBER FLOOR. ALL GAPS AROUND PIPES SHALL BE SEALED WATER TIGHT WITH A NON-SHRINK GROUT PER MANUFACTURERS STANDARD CONNECTION DETAIL AND SHALL MEET OR EXCEED REGIONAL PIPE CONNECTION STANDARDS.
- CONTRACTOR TO SUPPLY AND INSTALL ALL EXTERNAL CONNECTING PIPES.
- CONTRACTOR RESPONSIBLE FOR INSTALLATION OF ALL RISERS, MANHOLES, AND HATCHES. CONTRACTOR TO GROUT ALL MANHOLES AND HATCHES TO MATCH FINISHED SURFACE UNLESS SPECIFIED OTHERWISE.
- DRIP OR SPRAY IRRIGATION REQUIRED ON ALL UNITS WITH VEGETATION.

GENERAL NOTES

- MANUFACTURER TO PROVIDE ALL MATERIALS UNLESS OTHERWISE NOTED.
- ALL DIMENSIONS, ELEVATIONS, SPECIFICATIONS AND CAPACITIES ARE SUBJECT TO CHANGE. FOR PROJECT SPECIFIC DRAWINGS DETAIL EXACT DIMENSIONS, WEIGHTS AND ACCESSORIES PLEASE CONTACT MANUFACTURER.

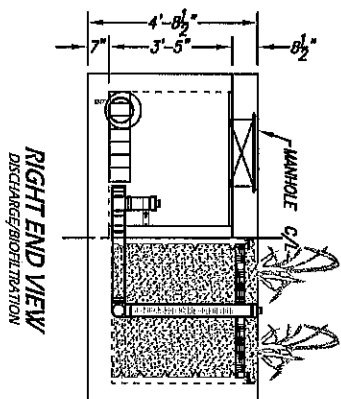
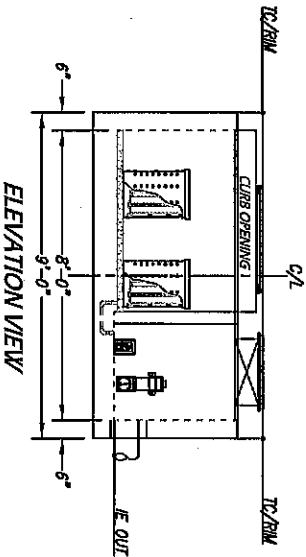
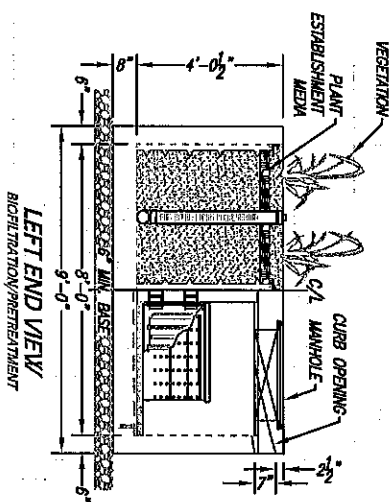
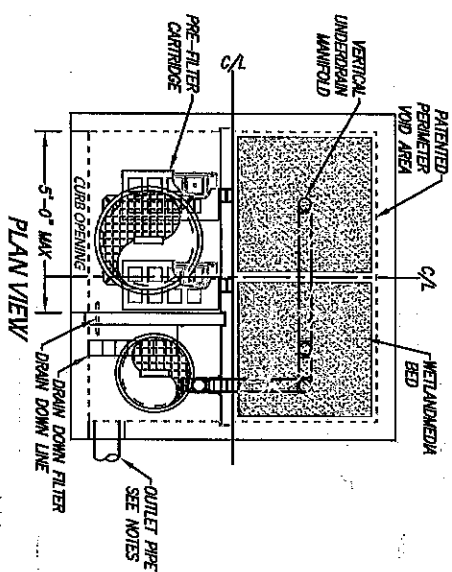

THE PRODUCT DESCRIBED MAY BE PROTECTED BY ONE OR MORE OF THE FOLLOWING PATENTS: 7,452,822; 7,452,823; 7,452,824; 7,452,825; 7,452,826; 7,452,827; 7,452,828; 7,452,829; 7,452,830; 7,452,831; 7,452,832; 7,452,833; 7,452,834; 7,452,835; 7,452,836; 7,452,837; 7,452,838; 7,452,839; 7,452,840; 7,452,841; 7,452,842; 7,452,843; 7,452,844; 7,452,845; 7,452,846; 7,452,847; 7,452,848; 7,452,849; 7,452,850; 7,452,851; 7,452,852; 7,452,853; 7,452,854; 7,452,855; 7,452,856; 7,452,857; 7,452,858; 7,452,859; 7,452,860; 7,452,861; 7,452,862; 7,452,863; 7,452,864; 7,452,865; 7,452,866; 7,452,867; 7,452,868; 7,452,869; 7,452,870; 7,452,871; 7,452,872; 7,452,873; 7,452,874; 7,452,875; 7,452,876; 7,452,877; 7,452,878; 7,452,879; 7,452,880; 7,452,881; 7,452,882; 7,452,883; 7,452,884; 7,452,885; 7,452,886; 7,452,887; 7,452,888; 7,452,889; 7,452,890; 7,452,891; 7,452,892; 7,452,893; 7,452,894; 7,452,895; 7,452,896; 7,452,897; 7,452,898; 7,452,899; 7,452,900; 7,452,901; 7,452,902; 7,452,903; 7,452,904; 7,452,905; 7,452,906; 7,452,907; 7,452,908; 7,452,909; 7,452,910; 7,452,911; 7,452,912; 7,452,913; 7,452,914; 7,452,915; 7,452,916; 7,452,917; 7,452,918; 7,452,919; 7,452,920; 7,452,921; 7,452,922; 7,452,923; 7,452,924; 7,452,925; 7,452,926; 7,452,927; 7,452,928; 7,452,929; 7,452,930; 7,452,931; 7,452,932; 7,452,933; 7,452,934; 7,452,935; 7,452,936; 7,452,937; 7,452,938; 7,452,939; 7,452,940; 7,452,941; 7,452,942; 7,452,943; 7,452,944; 7,452,945; 7,452,946; 7,452,947; 7,452,948; 7,452,949; 7,452,950; 7,452,951; 7,452,952; 7,452,953; 7,452,954; 7,452,955; 7,452,956; 7,452,957; 7,452,958; 7,452,959; 7,452,960; 7,452,961; 7,452,962; 7,452,963; 7,452,964; 7,452,965; 7,452,966; 7,452,967; 7,452,968; 7,452,969; 7,452,970; 7,452,971; 7,452,972; 7,452,973; 7,452,974; 7,452,975; 7,452,976; 7,452,977; 7,452,978; 7,452,979; 7,452,980; 7,452,981; 7,452,982; 7,452,983; 7,452,984; 7,452,985; 7,452,986; 7,452,987; 7,452,988; 7,452,989; 7,452,990; 7,452,991; 7,452,992; 7,452,993; 7,452,994; 7,452,995; 7,452,996; 7,452,997; 7,452,998; 7,452,999; 7,453,000.

THE INFORMATION CONTAINED IN THIS DRAWING IS THE SOLE PROPERTY OF MMS-8-8-C. IT IS TO BE USED ONLY FOR THE PROJECT AND SITE SPECIFICALLY IDENTIFIED HEREIN. ANY REPRODUCTION OR TRANSMISSION OF THIS INFORMATION IN ANY FORM OR BY ANY MEANS WITHOUT THE WRITTEN PERMISSION OF MMS-8-8-C IS PROHIBITED.



TREATMENT FLOW (CFS)	0.230
OPERATING HEAD (FT)	3.4
PRETREATMENT LOADING RATE (GPM/SF)	TBD
WETLAND MEDIA LOADING RATE (GPM/SF)	1.0

MMS-8-8-C
STORMWATER BIOFILTRATION SYSTEM
STANDARD DETAIL

SITE SPECIFIC DATA	
PROJECT NAME	
PROJECT LOCATION	
STRUCTURE ID	TREATMENT REQUIRED
VOLUME BASED (CF)	FLOW BASED (GFS)
TREATMENT REQ. AVAILABLE (FT)	
PEAK BYPASS REQUIRED (GFS) - IF APPLICABLE	
PIPE DATA	IE MATERIAL DIAMETER
INLET PIPE 1	
INLET PIPE 2	
OUTLET PIPE	
PRETREATMENT	BIOFILTRATION DISCHARGE
R/W ELEVATION	
SURFACE LOAD	PARKWAY OPEN PLANTER PARKWAY
FRAME & COVER	#30" N/A #24"
WETLANDMEDIA VOLUME (CY)	4.84
WETLANDMEDIA DELIVERY METHOD	TBD
ORIFICE SIZE (DIA. INCHES)	#2.16"
MAXIMUM PICK WEIGHT (LBS)	TBD

NOTES:

INSTALLATION NOTES

- CONTRACTOR TO PROVIDE ALL LABOR, EQUIPMENT, MATERIALS AND INCIDENTALS REQUIRED TO OFFLOAD AND INSTALL THE SYSTEM AND APPURTENANCES IN ACCORDANCE WITH THIS DRAWING AND THE MANUFACTURERS SPECIFICATIONS, UNLESS OTHERWISE STATED IN MANUFACTURERS CONTRACT.
- UNIT MUST BE INSTALLED ON LEVEL BASE. MANUFACTURER RECOMMENDS A MINIMUM 6" LEVEL ROCK BASE UNLESS SPECIFIED BY THE PROJECT ENGINEER. CONTRACTOR IS RESPONSIBLE TO VERIFY PROJECT ENGINEERS RECOMMENDED BASE SPECIFICATIONS.
- ALL PIPES MUST BE FLUSH WITH INSIDE SURFACE OF CONCRETE (PIPES CANNOT INTRUDE BEYOND FLUSH). INVERT OF OUTFLOW PIPE MUST BE FLUSH WITH DISCHARGE CHAMBER FLOOR. ALL GAPS AROUND PIPES SHALL BE SEALED WATER TIGHT WITH A NON-SHRINK GROUT PER MANUFACTURERS STANDARD CONNECTION DETAIL AND SHALL MEET OR EXCEED REGIONAL PIPE CONNECTION STANDARDS.
- CONTRACTOR TO SUPPLY AND INSTALL ALL EXTERNAL CONNECTING PIPES.
- CONTRACTOR RESPONSIBLE FOR INSTALLATION OF ALL RISERS, MANHOLES AND HATCHES. CONTRACTOR TO GROUT ALL MANHOLES AND HATCHES TO MATCH FINISHED SURFACE UNLESS SPECIFIED OTHERWISE.
- DRIP OR SPRAY IRRIGATION REQUIRED ON ALL UNITS WITH VEGETATION.

GENERAL NOTES

- MANUFACTURER TO PROVIDE ALL MATERIALS UNLESS OTHERWISE NOTED.
- ALL DIMENSIONS, ELEVATIONS, SPECIFICATIONS AND CAPACITIES ARE SUBJECT TO CHANGE FOR PROJECT SPECIFIC DRAWINGS DETAILING EXACT DIMENSIONS, HEIGHTS AND ACCESSORIES PLEASE CONTACT MANUFACTURER.

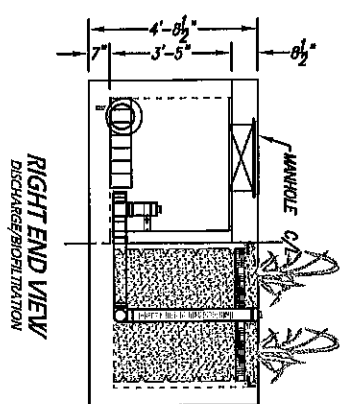
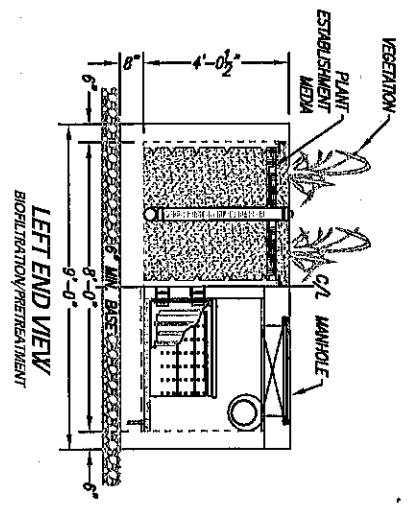
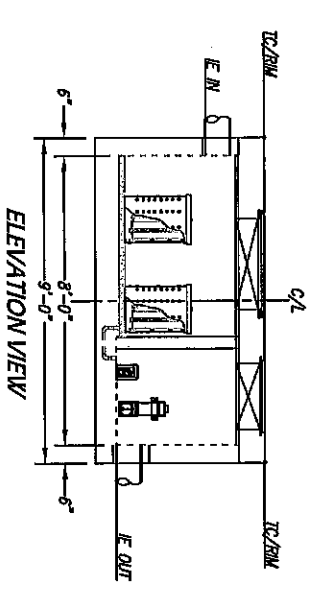
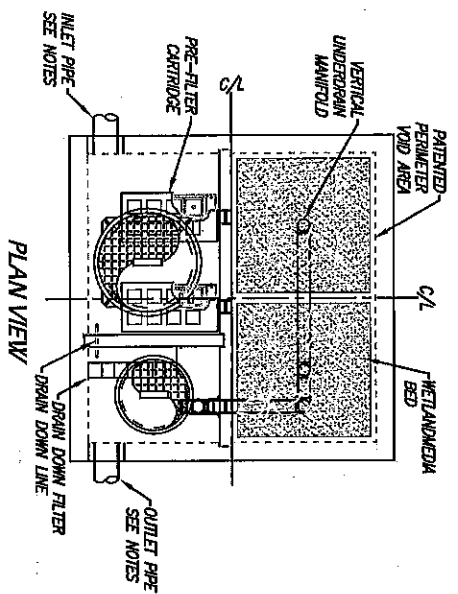

THE PRODUCT DESCRIBED MAY BE PROTECTED BY ONE OR MORE OF THE FOLLOWING INTELLECTUAL PROPERTY RIGHTS: PATENTS, TRADEMARKS, PATENTS OR OTHER RIGHTS FROM PROPRIETARY AND CONFIDENTIAL. THE INFORMATION CONTAINED IN THIS DRAWING IS THE SOLE PROPERTY OF MMS. ANY REPRODUCTION IN PART OR AS A WHOLE WITHOUT THE WRITTEN PERMISSION OF MMS IS PROHIBITED.



TREATMENT FLOW (GFS)	0.230
OPERATING HEAD (FT)	3.4
PRETREATMENT LOADING RATE (GPM/SF)	TBD
WETLAND MEDIA LOADING RATE (GPM/SF)	1.0

MMS-L-8-8-V
STORMWATER BIOFILTRATION SYSTEM
STANDARD DETAIL

SITE SPECIFIC DATA			
PROJECT NAME			
PROJECT LOCATION			
STRUCTURE ID	TREATMENT REQUIRED		
VOLUME BASED (CF)	FLOW BASED (CFS)		
TREATMENT HZ AVAILABLE (FT)			
PEAK BYPASS REQUIRED (CFS) - IF APPLICABLE			
PIPE DATA	LE	MATERIAL	DIAMETER
INLET PIPE 1			
INLET PIPE 2			
OUTLET PIPE			
PRETREATMENT	BIOFILTRATION		DISCHARGE
RIM ELEVATION			
SURFACE LOAD	PARKWAY	OPEN PLANTER	PARKWAY
FRAME & COVER	430"	N/A	424"
WETLANDMEDIA VOLUME (C1)			7.26
WETLANDMEDIA DELIVERY METHOD			TBD
ORIFICE SIZE (DIA. INCHES)			42.66"
MAXIMUM PICK WEIGHT (LBS)			TBD
NOTES:			

INSTALLATION NOTES

- CONTRACTOR TO PROVIDE ALL LABOR, EQUIPMENT, MATERIALS AND INCIDENTALS REQUIRED TO OFFLOAD AND INSTALL THE SYSTEM AND APPOINTMENTS IN ACCORDANCE WITH THIS DRAWING AND THE MANUFACTURERS SPECIFICATIONS, UNLESS OTHERWISE STATED IN MANUFACTURERS CONTRACT.
- UNIT MUST BE INSTALLED ON LEVEL BASE. MANUFACTURER RECOMMENDS A MINIMUM 6" LEVEL ROCK BASE UNLESS SPECIFIED BY THE PROJECT ENGINEER. CONTRACTOR IS RESPONSIBLE TO VERIFY PROJECT ENGINEERS RECOMMENDED BASE SPECIFICATIONS.
- ALL PIPES MUST BE FLUSH WITH INSIDE SURFACE OF CONCRETE (PIPES CANNOT INTRUDE BEYOND FLUSH). INVERT OF OUTFLOW PIPE MUST BE FLUSH WITH DISCHARGE CHAMBER FLOOR. ALL GAPS AROUND PIPES SHALL BE SEALED WATER TIGHT WITH A NON-SHRINK GROUT PER MANUFACTURERS STANDARD CONNECTION DETAIL AND SHALL MEET OR EXCEED REGIONAL PIPE CONNECTION STANDARDS.
- CONTRACTOR TO SUPPLY AND INSTALL ALL EXTERNAL CONNECTING PIPES.
- CONTRACTOR RESPONSIBLE FOR INSTALLATION OF ALL RISERS, MANHOLES, AND HATCHES. CONTRACTOR TO GROUT ALL MANHOLES AND HATCHES TO MATCH FINISHED SURFACE UNLESS SPECIFIED OTHERWISE.
- DRIP OR SPRAY IRRIGATION REQUIRED ON ALL UNITS WITH VEGETATION.

GENERAL NOTES

- MANUFACTURER TO PROVIDE ALL MATERIALS UNLESS OTHERWISE NOTED.
- ALL DIMENSIONS, ELEVATIONS, SPECIFICATIONS AND CAPACITIES ARE SUBJECT TO CHANGE. FOR PROJECT SPECIFIC DRAWINGS DETAILING EXACT DIMENSIONS, WEIGHTS AND ACCESSORIES PLEASE CONTACT MANUFACTURER.

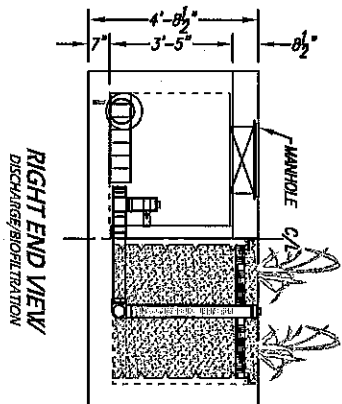
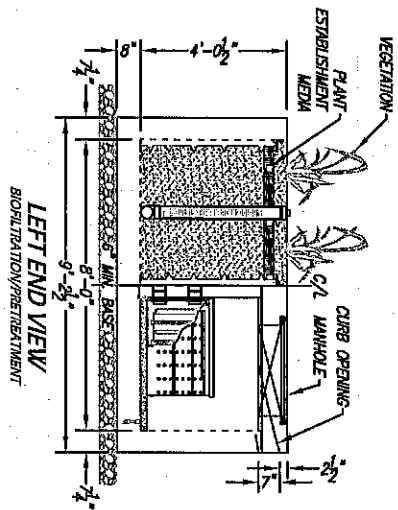
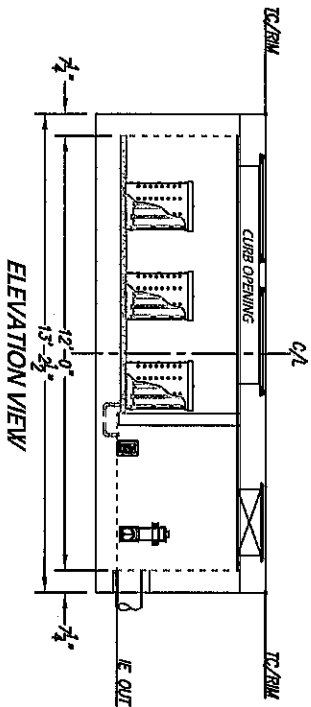
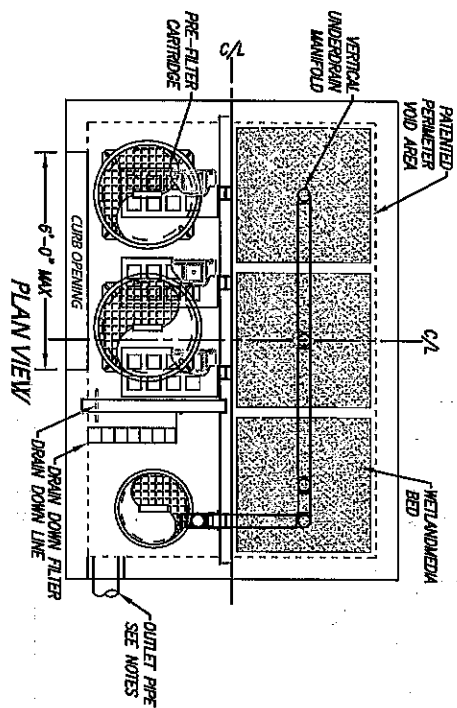

THE PRODUCT DESCRIBED MAY BE PROVIDED BY ONE OR MORE OF THE FOLLOWING MANUFACTURERS: 765.202.7400, 202.765.4200, 765.202.7400, 202.765.4200, 765.202.7400, 202.765.4200. FINISHES OR OTHER FINISHES REMAINS.

PROPRIETARY AND CONFIDENTIAL. THE INFORMATION CONTAINED IN THIS DRAWING IS THE SOLE PROPERTY OF K&W LANDSCAPE SYSTEMS. ANY REPRODUCTION IN PART OR AS A WHOLE WITHOUT THE WRITTEN PERMISSION OF K&W LANDSCAPE SYSTEMS IS PROHIBITED.



TREATMENT FLOW (CFS)	0.346
OPERATING HEAD (FT)	3.4
PRETREATMENT LOADING RATE (GPM/SF)	TBD
WETLAND MEDIA LOADING RATE (GPM/SF)	1.0

MWS-L-8-12-C
STORMWATER BIOFILTRATION SYSTEM
STANDARD DETAIL

SITE SPECIFIC DATA	
PROJECT NAME	
PROJECT LOCATION	
STRUCTURE ID	TREATMENT REQUIRED
VOLUME BASED (CF)	FLOW BASED (GFS)
TREATMENT HEAD AVAILABLE (FT)	
PEAK BYPASS REQUIRED (GFS) - IF APPLICABLE	
PIPE DATA	IE MATERIAL DIAMETER
INLET PIPE 1	
INLET PIPE 2	
OUTLET PIPE	DISCHARGE
PRETREATMENT	BIOFILTRATION
R/W ELEVATION	
SURFACE LOAD	PARKWAY OPEN PLANTER PARKWAY
FRAME & COVER	#30" N/A #24"
WETLAND MEDIA VOLUME (CY)	7.26
WETLAND MEDIA DELIVERY METHOD	TBD
ORIFICE SIZE (DIA. INCHES)	#2.65"
MAXIMUM PICK WEIGHT (LBS)	TBD

NOTES:

INSTALLATION NOTES

- CONTRACTOR TO PROVIDE ALL LABOR, EQUIPMENT, MATERIALS AND INCIDENTALS REQUIRED TO OBTAIN AND INSTALL THE SYSTEM AND APPURTENANCES IN ACCORDANCE WITH THIS DRAWING AND THE MANUFACTURERS SPECIFICATIONS, UNLESS OTHERWISE STATED IN MANUFACTURERS CONTRACT.
- UNIT MUST BE INSTALLED ON LEVEL, BASE MANUFACTURER RECOMMENDS A MINIMUM 6" LEVEL ROCK BASE UNLESS SPECIFIED BY THE PROJECT ENGINEER. CONTRACTOR IS RESPONSIBLE TO VERIFY PROJECT ENGINEERS RECOMMENDED BASE SPECIFICATIONS.
- ALL PIPES MUST BE FLUSH WITH INSIDE SURFACE OF CONCRETE. (PIPES CANNOT INTRUDE BEYOND FLUSH). INVERT OF OUTFLOW PIPE MUST BE FLUSH WITH DISCHARGE CHAMBER FLOOR. ALL GAPS AROUND PIPES SHALL BE SEALED WATER TIGHT WITH A NON-SHRINK GROUT PER MANUFACTURERS STANDARD CONNECTION DETAIL AND SHALL MEET OR EXCEED REGIONAL PIPE CONNECTION STANDARDS.
- CONTRACTOR TO SUPPLY AND INSTALL ALL EXTERNAL CONNECTING PIPES.
- CONTRACTOR RESPONSIBLE FOR INSTALLATION OF ALL RISERS, MANHOLES AND HATCHES. CONTRACTOR TO GROUT ALL MANHOLES AND HATCHES TO MATCH FINISHED SURFACE UNLESS SPECIFIED OTHERWISE.
- DRIP OR SPRAY IRRIGATION REQUIRED ON ALL UNITS WITH VEGETATION.

GENERAL NOTES

- MANUFACTURER TO PROVIDE ALL MATERIALS UNLESS OTHERWISE NOTED.
- ALL DIMENSIONS, ELEVATIONS, SPECIFICATIONS AND CAPACITIES ARE SUBJECT TO CHANGE FOR PROJECT SPECIFIC DRAWINGS DETAILING EXACT DIMENSIONS, WEIGHTS AND ACCESSORIES PLEASE CONTACT MANUFACTURER.

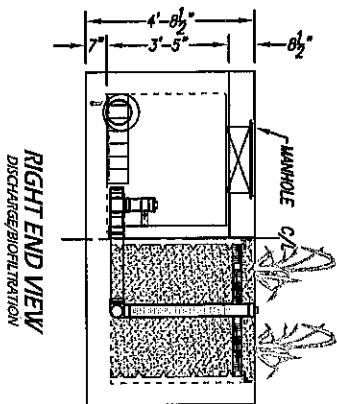
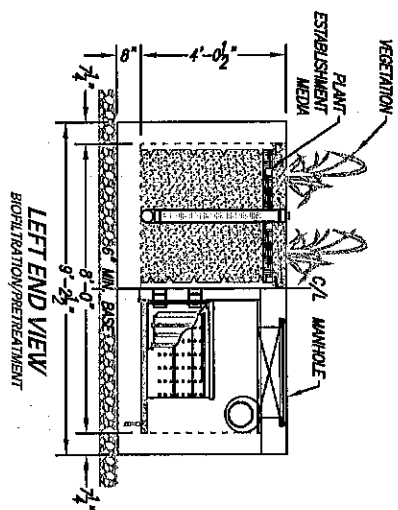
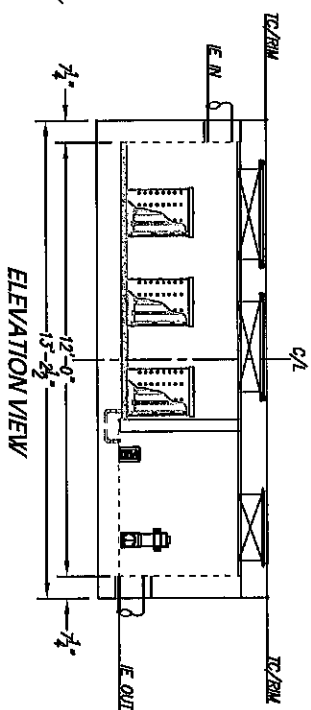
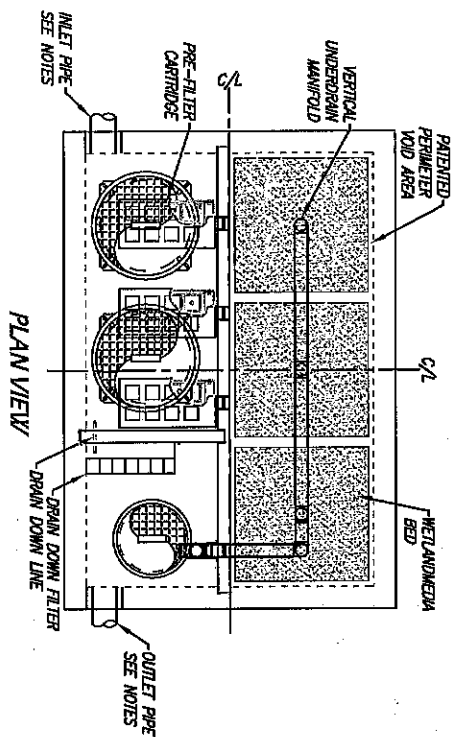

THE PRODUCT DESCRIBED MAY BE PROTECTED BY ONE OR MORE OF THE FOLLOWING US PATENTS: 7,822,422; 7,822,423; 7,822,424; 7,822,425; 7,822,426; 7,822,427; 7,822,428; 7,822,429; 7,822,430; 7,822,431; 7,822,432; 7,822,433; 7,822,434; 7,822,435; 7,822,436; 7,822,437; 7,822,438; 7,822,439; 7,822,440; 7,822,441; 7,822,442; 7,822,443; 7,822,444; 7,822,445; 7,822,446; 7,822,447; 7,822,448; 7,822,449; 7,822,450; 7,822,451; 7,822,452; 7,822,453; 7,822,454; 7,822,455; 7,822,456; 7,822,457; 7,822,458; 7,822,459; 7,822,460; 7,822,461; 7,822,462; 7,822,463; 7,822,464; 7,822,465; 7,822,466; 7,822,467; 7,822,468; 7,822,469; 7,822,470; 7,822,471; 7,822,472; 7,822,473; 7,822,474; 7,822,475; 7,822,476; 7,822,477; 7,822,478; 7,822,479; 7,822,480; 7,822,481; 7,822,482; 7,822,483; 7,822,484; 7,822,485; 7,822,486; 7,822,487; 7,822,488; 7,822,489; 7,822,490; 7,822,491; 7,822,492; 7,822,493; 7,822,494; 7,822,495; 7,822,496; 7,822,497; 7,822,498; 7,822,499; 7,822,500; 7,822,501; 7,822,502; 7,822,503; 7,822,504; 7,822,505; 7,822,506; 7,822,507; 7,822,508; 7,822,509; 7,822,510; 7,822,511; 7,822,512; 7,822,513; 7,822,514; 7,822,515; 7,822,516; 7,822,517; 7,822,518; 7,822,519; 7,822,520; 7,822,521; 7,822,522; 7,822,523; 7,822,524; 7,822,525; 7,822,526; 7,822,527; 7,822,528; 7,822,529; 7,822,530; 7,822,531; 7,822,532; 7,822,533; 7,822,534; 7,822,535; 7,822,536; 7,822,537; 7,822,538; 7,822,539; 7,822,540; 7,822,541; 7,822,542; 7,822,543; 7,822,544; 7,822,545; 7,822,546; 7,822,547; 7,822,548; 7,822,549; 7,822,550; 7,822,551; 7,822,552; 7,822,553; 7,822,554; 7,822,555; 7,822,556; 7,822,557; 7,822,558; 7,822,559; 7,822,560; 7,822,561; 7,822,562; 7,822,563; 7,822,564; 7,822,565; 7,822,566; 7,822,567; 7,822,568; 7,822,569; 7,822,570; 7,822,571; 7,822,572; 7,822,573; 7,822,574; 7,822,575; 7,822,576; 7,822,577; 7,822,578; 7,822,579; 7,822,580; 7,822,581; 7,822,582; 7,822,583; 7,822,584; 7,822,585; 7,822,586; 7,822,587; 7,822,588; 7,822,589; 7,822,590; 7,822,591; 7,822,592; 7,822,593; 7,822,594; 7,822,595; 7,822,596; 7,822,597; 7,822,598; 7,822,599; 7,822,600; 7,822,601; 7,822,602; 7,822,603; 7,822,604; 7,822,605; 7,822,606; 7,822,607; 7,822,608; 7,822,609; 7,822,610; 7,822,611; 7,822,612; 7,822,613; 7,822,614; 7,822,615; 7,822,616; 7,822,617; 7,822,618; 7,822,619; 7,822,620; 7,822,621; 7,822,622; 7,822,623; 7,822,624; 7,822,625; 7,822,626; 7,822,627; 7,822,628; 7,822,629; 7,822,630; 7,822,631; 7,822,632; 7,822,633; 7,822,634; 7,822,635; 7,822,636; 7,822,637; 7,822,638; 7,822,639; 7,822,640; 7,822,641; 7,822,642; 7,822,643; 7,822,644; 7,822,645; 7,822,646; 7,822,647; 7,822,648; 7,822,649; 7,822,650; 7,822,651; 7,822,652; 7,822,653; 7,822,654; 7,822,655; 7,822,656; 7,822,657; 7,822,658; 7,822,659; 7,822,660; 7,822,661; 7,822,662; 7,822,663; 7,822,664; 7,822,665; 7,822,666; 7,822,667; 7,822,668; 7,822,669; 7,822,670; 7,822,671; 7,822,672; 7,822,673; 7,822,674; 7,822,675; 7,822,676; 7,822,677; 7,822,678; 7,822,679; 7,822,680; 7,822,681; 7,822,682; 7,822,683; 7,822,684; 7,822,685; 7,822,686; 7,822,687; 7,822,688; 7,822,689; 7,822,690; 7,822,691; 7,822,692; 7,822,693; 7,822,694; 7,822,695; 7,822,696; 7,822,697; 7,822,698; 7,822,699; 7,822,700; 7,822,701; 7,822,702; 7,822,703; 7,822,704; 7,822,705; 7,822,706; 7,822,707; 7,822,708; 7,822,709; 7,822,710; 7,822,711; 7,822,712; 7,822,713; 7,822,714; 7,822,715; 7,822,716; 7,822,717; 7,822,718; 7,822,719; 7,822,720; 7,822,721; 7,822,722; 7,822,723; 7,822,724; 7,822,725; 7,822,726; 7,822,727; 7,822,728; 7,822,729; 7,822,730; 7,822,731; 7,822,732; 7,822,733; 7,822,734; 7,822,735; 7,822,736; 7,822,737; 7,822,738; 7,822,739; 7,822,740; 7,822,741; 7,822,742; 7,822,743; 7,822,744; 7,822,745; 7,822,746; 7,822,747; 7,822,748; 7,822,749; 7,822,750; 7,822,751; 7,822,752; 7,822,753; 7,822,754; 7,822,755; 7,822,756; 7,822,757; 7,822,758; 7,822,759; 7,822,760; 7,822,761; 7,822,762; 7,822,763; 7,822,764; 7,822,765; 7,822,766; 7,822,767; 7,822,768; 7,822,769; 7,822,770; 7,822,771; 7,822,772; 7,822,773; 7,822,774; 7,822,775; 7,822,776; 7,822,777; 7,822,778; 7,822,779; 7,822,780; 7,822,781; 7,822,782; 7,822,783; 7,822,784; 7,822,785; 7,822,786; 7,822,787; 7,822,788; 7,822,789; 7,822,790; 7,822,791; 7,822,792; 7,822,793; 7,822,794; 7,822,795; 7,822,796; 7,822,797; 7,822,798; 7,822,799; 7,822,800; 7,822,801; 7,822,802; 7,822,803; 7,822,804; 7,822,805; 7,822,806; 7,822,807; 7,822,808; 7,822,809; 7,822,810; 7,822,811; 7,822,812; 7,822,813; 7,822,814; 7,822,815; 7,822,816; 7,822,817; 7,822,818; 7,822,819; 7,822,820; 7,822,821; 7,822,822; 7,822,823; 7,822,824; 7,822,825; 7,822,826; 7,822,827; 7,822,828; 7,822,829; 7,822,830; 7,822,831; 7,822,832; 7,822,833; 7,822,834; 7,822,835; 7,822,836; 7,822,837; 7,822,838; 7,822,839; 7,822,840; 7,822,841; 7,822,842; 7,822,843; 7,822,844; 7,822,845; 7,822,846; 7,822,847; 7,822,848; 7,822,849; 7,822,850; 7,822,851; 7,822,852; 7,822,853; 7,822,854; 7,822,855; 7,822,856; 7,822,857; 7,822,858; 7,822,859; 7,822,860; 7,822,861; 7,822,862; 7,822,863; 7,822,864; 7,822,865; 7,822,866; 7,822,867; 7,822,868; 7,822,869; 7,822,870; 7,822,871; 7,822,872; 7,822,873; 7,822,874; 7,822,875; 7,822,876; 7,822,877; 7,822,878; 7,822,879; 7,822,880; 7,822,881; 7,822,882; 7,822,883; 7,822,884; 7,822,885; 7,822,886; 7,822,887; 7,822,888; 7,822,889; 7,822,890; 7,822,891; 7,822,892; 7,822,893; 7,822,894; 7,822,895; 7,822,896; 7,822,897; 7,822,898; 7,822,899; 7,822,900; 7,822,901; 7,822,902; 7,822,903; 7,822,904; 7,822,905; 7,822,906; 7,822,907; 7,822,908; 7,822,909; 7,822,910; 7,822,911; 7,822,912; 7,822,913; 7,822,914; 7,822,915; 7,822,916; 7,822,917; 7,822,918; 7,822,919; 7,822,920; 7,822,921; 7,822,922; 7,822,923; 7,822,924; 7,822,925; 7,822,926; 7,822,927; 7,822,928; 7,822,929; 7,822,930; 7,822,931; 7,822,932; 7,822,933; 7,822,934; 7,822,935; 7,822,936; 7,822,937; 7,822,938; 7,822,939; 7,822,940; 7,822,941; 7,822,942; 7,822,943; 7,822,944; 7,822,945; 7,822,946; 7,822,947; 7,822,948; 7,822,949; 7,822,950; 7,822,951; 7,822,952; 7,822,953; 7,822,954; 7,822,955; 7,822,956; 7,822,957; 7,822,958; 7,822,959; 7,822,960; 7,822,961; 7,822,962; 7,822,963; 7,822,964; 7,822,965; 7,822,966; 7,822,967; 7,822,968; 7,822,969; 7,822,970; 7,822,971; 7,822,972; 7,822,973; 7,822,974; 7,822,975; 7,822,976; 7,822,977; 7,822,978; 7,822,979; 7,822,980; 7,822,981; 7,822,982; 7,822,983; 7,822,984; 7,822,985; 7,822,986; 7,822,987; 7,822,988; 7,822,989; 7,822,990; 7,822,991; 7,822,992; 7,822,993; 7,822,994; 7,822,995; 7,822,996; 7,822,997; 7,822,998; 7,822,999; 7,823,000.

PROPRIETARY AND CONFIDENTIAL. THE INFORMATION CONTAINED IN THIS DRAWING IS THE SOLE PROPERTY OF MWS. IT IS TO BE USED ONLY FOR THE PROJECT AND NOT BE REPRODUCED OR TRANSMITTED IN ANY FORM OR BY ANY MEANS, ELECTRONIC OR MECHANICAL, INCLUDING PHOTOCOPYING, RECORDING, OR BY ANY INFORMATION STORAGE AND RETRIEVAL SYSTEM, WITHOUT THE WRITTEN PERMISSION OF MWS. MWS SHALL NOT BE RESPONSIBLE FOR THE RESULTS OF OTHER ENGINEERING DRAWINGS.

TREATMENT FLOW (GFS)	0.346
OPERATING HEAD (FT)	3.4
PRETREATMENT LOADING RATE (GPM/SF)	TBD
WETLAND MEDIA LOADING RATE (GPM/SF)	1.0

MWS-L-8-12-V
STORMWATER BIOFILTRATION SYSTEM
STANDARD DETAIL



SITE SPECIFIC DATA

PROJECT NAME			
PROJECT LOCATION			
STRUCTURE ID			
	TREATMENT REQUIRED		
VOLUME BASED (CF)	FLOW BASED (CFS)		
TREATMENT HQL AVAILABLE (FT)			
PEAK BYPASS REQUIRED (CFS) - IF APPLICABLE			
PIPE DATA	I/E	MATERIAL	DIAMETER
INLET PIPE 1			
INLET PIPE 2			
OUTLET PIPE			
	PRETREATMENT	BIOTRITATION	DISCHARGE
R/W ELEVATION			
SURFACE LOAD	PARKWAY	OPEN PLANTER	PARKWAY
FRAME & COVER	430"	N/A	624"
WETLANDMEDIA VOLUME (CY)			9.50
ORIFICE SIZE (DIA. INCHES)			TBD
MAXIMUM PICK WEIGHT (LBS)			TBD
NOTES:			

INSTALLATION NOTES

1. CONTRACTOR TO PROVIDE ALL LABOR, EQUIPMENT, MATERIALS AND INCIDENTALS REQUIRED TO OFFLOAD AND INSTALL THE SYSTEM AND APPURTENANCES IN ACCORDANCE WITH THIS DRAWING AND THE MANUFACTURERS SPECIFICATIONS, UNLESS OTHERWISE STATED IN MANUFACTURERS CONTRACT.
2. UNIT MUST BE INSTALLED ON LEVEL BASE. MANUFACTURER RECOMMENDS A MINIMUM 6" LEVEL ROCK BASE UNLESS SPECIFIED BY THE PROJECT ENGINEER. CONTRACTOR IS RESPONSIBLE TO VERIFY PROJECT ENGINEERS RECOMMENDED BASE SPECIFICATIONS. ALL PIPES MUST BE FLUSH WITH INSIDE SURFACE OF CONCRETE. (PIPES CANNOT intrude BEYOND FLUSH). INERT OF OUTFLOW PIPE MUST BE FLUSH WITH DISCHARGE CHAMBER FLOOR. ALL GAPS AROUND PIPES SHALL BE SEALED WATER TIGHT WITH A NON-SHRINK GROUT PER MANUFACTURERS STANDARD CONNECTION DETAIL AND SHALL MEET OR EXCEED REGIONAL PIPE CONNECTION STANDARDS.
3. CONTRACTOR TO SUPPLY AND INSTALL ALL EXTERNAL CONNECTING PIPES.
4. CONTRACTOR RESPONSIBLE FOR INSTALLATION OF ALL RISERS, MANHOLES, AND HATCHES. CONTRACTOR TO GROUT ALL MANHOLES AND HATCHES TO MATCH FINISHED SURFACE UNLESS SPECIFIED OTHERWISE. DRIP OR SPRAY IRRIGATION REQUIRED ON ALL UNITS WITH VEGETATION.

GENERAL NOTES

1. MANUFACTURER TO PROVIDE ALL MATERIALS UNLESS OTHERWISE NOTED.
2. ALL DIMENSIONS, ELEVATIONS, SPECIFICATIONS AND CAPACITIES ARE SUBJECT TO CHANGE. FOR PROJECT SPECIFIC DRAWINGS DETAILING EXACT DIMENSIONS, WEIGHTS AND ACCESSORIES PLEASE CONTACT MANUFACTURER.

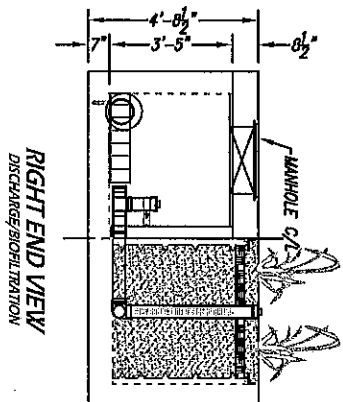
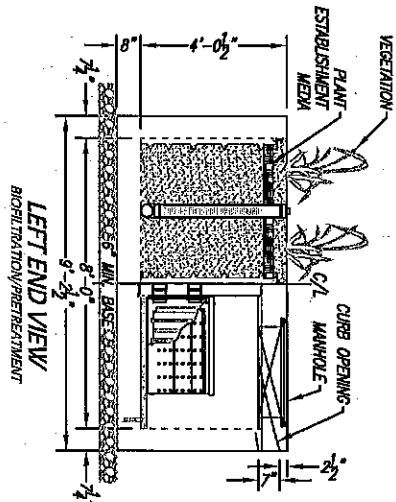
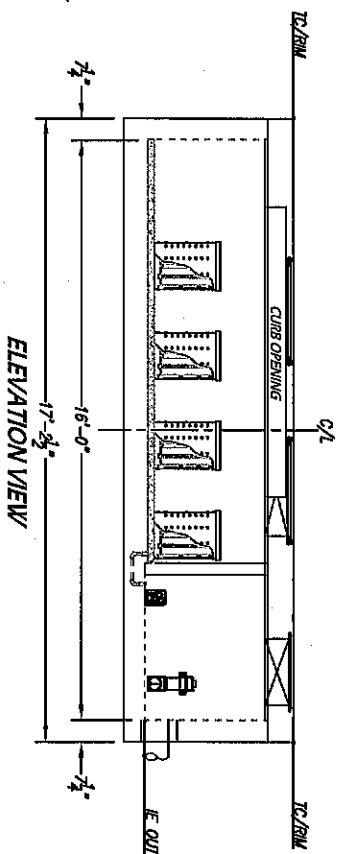
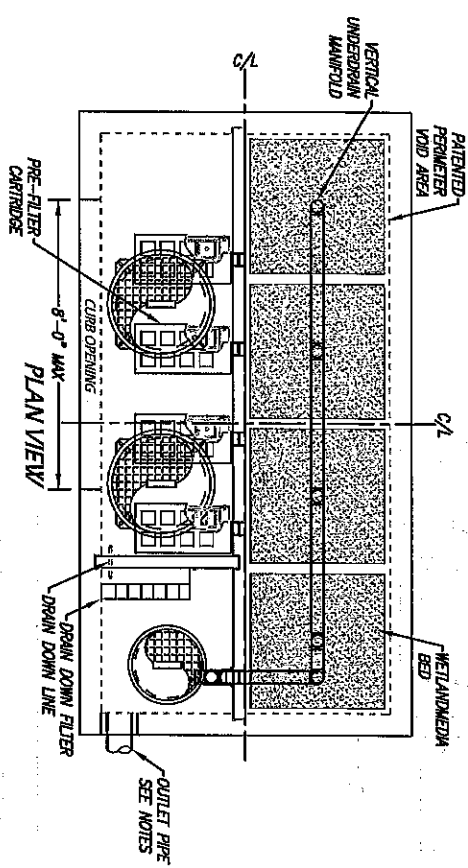

TREATMENT FLOW (CFS)	0.482
OPERATING HEAD (FT)	3.4
PRETREATMENT LOADING RATE (GPM/5F)	TBD
WETLAND MEDIA LOADING RATE (GPM/5F)	1.0

MWS-L-8-16-C
STORMWATER BIOFILTRATION SYSTEM
STANDARD DETAIL



THE PRODUCT ASSIGNED MAY BE THE PROPERTY OF ONE OR MORE OF THE REGISTERED ENGINEERS OR ARCHITECTS OF MICHIGAN AND IS NOT TO BE REPRODUCED OR TRANSMITTED IN ANY FORM OR BY ANY MEANS, ELECTRONIC OR MECHANICAL, INCLUDING PHOTOCOPYING, RECORDING, OR BY ANY INFORMATION STORAGE AND RETRIEVAL SYSTEM, WITHOUT THE WRITTEN PERMISSION OF MANDP WETLANDS SYSTEMS, INC.

PROPRIETARY AND CONFIDENTIAL.

SITE SPECIFIC DATA	
PROJECT NAME	
PROJECT LOCATION	
STRUCTURE ID	TREATMENT REQUIRED
VOLUME BASED (CY)	FLOW BASED (CFS)
TREATMENT HGL AVAILABLE (FT)	
PEAK BRASS REQUIRED (CFS) - IF APPLICABLE	
PIPE DATA	IE MATERIAL DRAINER
INLET PIPE 1	
INLET PIPE 2	
OUTLET PIPE	
PRETREATMENT	BIOFILTRATION DISCHARGE
RIM ELEVATION	
SURFACE LOAD	PARKWAY OPEN PLANTER PARKWAY
FRAME & COVER	#30" N/A #24"
WETLAND MEDIA VOLUME (CY)	9.50
WETLAND MEDIA DELIVERY METHOD	TBD
ORIFICE SIZE (O.U. INCHES)	#3.07"
MAXIMUM PICK WEIGHT (LBS)	TBD

NOTES:

INSTALLATION NOTES

- CONTRACTOR TO PROVIDE ALL LABOR, EQUIPMENT, MATERIALS AND INCIDENTALS REQUIRED TO OFFLOAD AND INSTALL THE SYSTEM AND APPURTENANCES IN ACCORDANCE WITH THIS DRAWING AND THE MANUFACTURERS SPECIFICATIONS, UNLESS OTHERWISE STATED IN MANUFACTURERS CONTRACT.
- UNIT MUST BE INSTALLED ON LEVEL BASE. MANUFACTURER RECOMMENDS A MINIMUM 6" LEVEL ROCK BASE UNLESS SPECIFIED BY THE PROJECT ENGINEER. CONTRACTOR IS RESPONSIBLE TO VERIFY PROJECT ENGINEERS RECOMMENDED BASE SPECIFICATIONS.
- ALL PIPES MUST BE FLUSH WITH INSIDE SURFACE OF CONCRETE. (PIPES CANNOT INTRUDE BEYOND FLUSH). INVERT OF OUTFLOW PIPE MUST BE FLUSH WITH DISCHARGE CHAMBER FLOOR. ALL GAPS AROUND PIPES SHALL BE SEALED WATER TIGHT WITH A NON-SHRINK GROUT PER MANUFACTURERS STANDARD CONNECTION DETAIL AND SHALL MEET OR EXCEED REGIONAL PIPE CONNECTION STANDARDS.
- CONTRACTOR TO SUPPLY AND INSTALL ALL EXTERNAL CONNECTING PIPES.
- CONTRACTOR RESPONSIBLE FOR INSTALLATION OF ALL RISERS, MANHOLES, AND HATCHES. CONTRACTOR TO GROUT ALL MANHOLES AND HATCHES TO MATCH FINISHED SURFACE UNLESS SPECIFIED OTHERWISE.
- DIMP OR SPRAY IRRIGATION REQUIRED ON ALL UNITS WITH VEGETATION.

GENERAL NOTES

- MANUFACTURER TO PROVIDE ALL MATERIALS UNLESS OTHERWISE NOTED.
- ALL DIMENSIONS, ELEVATIONS, SPECIFICATIONS AND CAPACITIES ARE SUBJECT TO CHANGE FOR PROJECT SPECIFIC DRAWINGS DETAILING EXACT DIMENSIONS, WEIGHTS AND ACCESSORIES PLEASE CONTACT MANUFACTURER.

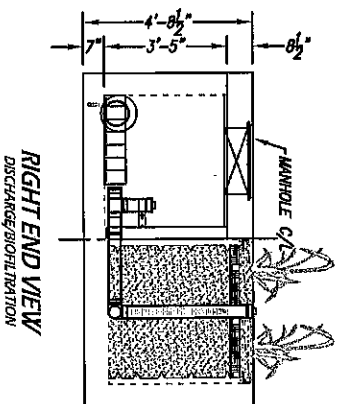
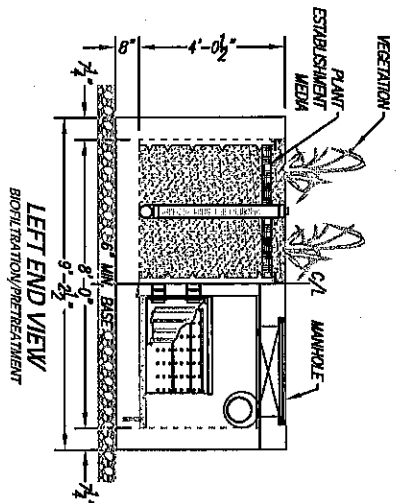
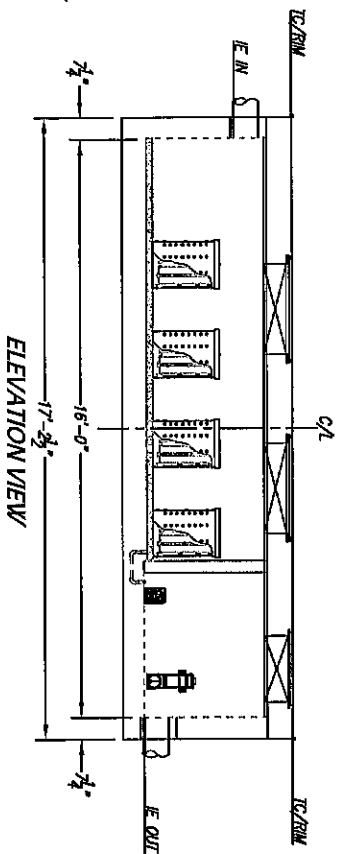
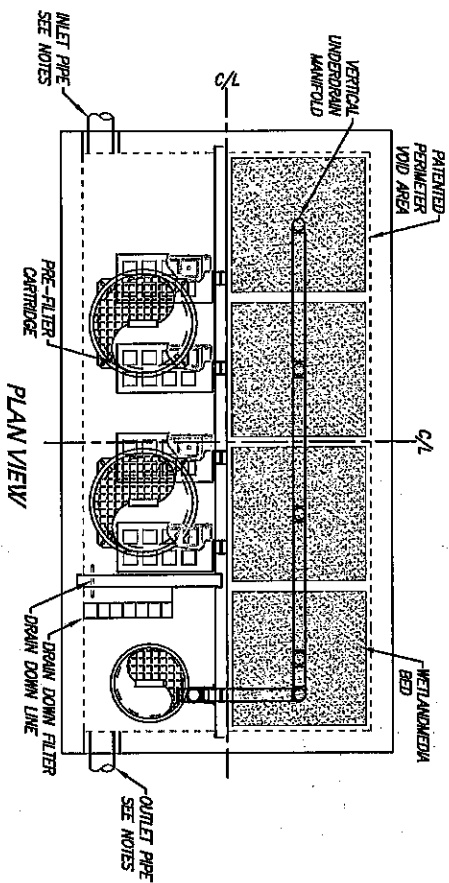

TREATMENT FLOW (CFS)	0.482
OPERATING HEAD (FT)	3.4
PRETREATMENT LOADING RATE (GPM/SF)	TBD
WETLAND MEDIA LOADING RATE (GPM/SF)	1.0

MWS-1-8-16-V
STORMWATER BIOFILTRATION SYSTEM
STANDARD DETAIL

THE ABOVE DESIGN MAY BE REPRODUCED BY ONE OR MORE OF THE FOLLOWING US PATENTS: 7,832,822; 7,832,823; 7,832,824; 7,832,825; 7,832,826; 7,832,827; 7,832,828; 7,832,829; 7,832,830; 7,832,831; 7,832,832; 7,832,833; 7,832,834; 7,832,835; 7,832,836; 7,832,837; 7,832,838; 7,832,839; 7,832,840; 7,832,841; 7,832,842; 7,832,843; 7,832,844; 7,832,845; 7,832,846; 7,832,847; 7,832,848; 7,832,849; 7,832,850; 7,832,851; 7,832,852; 7,832,853; 7,832,854; 7,832,855; 7,832,856; 7,832,857; 7,832,858; 7,832,859; 7,832,860; 7,832,861; 7,832,862; 7,832,863; 7,832,864; 7,832,865; 7,832,866; 7,832,867; 7,832,868; 7,832,869; 7,832,870; 7,832,871; 7,832,872; 7,832,873; 7,832,874; 7,832,875; 7,832,876; 7,832,877; 7,832,878; 7,832,879; 7,832,880; 7,832,881; 7,832,882; 7,832,883; 7,832,884; 7,832,885; 7,832,886; 7,832,887; 7,832,888; 7,832,889; 7,832,890; 7,832,891; 7,832,892; 7,832,893; 7,832,894; 7,832,895; 7,832,896; 7,832,897; 7,832,898; 7,832,899; 7,832,900; 7,832,901; 7,832,902; 7,832,903; 7,832,904; 7,832,905; 7,832,906; 7,832,907; 7,832,908; 7,832,909; 7,832,910; 7,832,911; 7,832,912; 7,832,913; 7,832,914; 7,832,915; 7,832,916; 7,832,917; 7,832,918; 7,832,919; 7,832,920; 7,832,921; 7,832,922; 7,832,923; 7,832,924; 7,832,925; 7,832,926; 7,832,927; 7,832,928; 7,832,929; 7,832,930; 7,832,931; 7,832,932; 7,832,933; 7,832,934; 7,832,935; 7,832,936; 7,832,937; 7,832,938; 7,832,939; 7,832,940; 7,832,941; 7,832,942; 7,832,943; 7,832,944; 7,832,945; 7,832,946; 7,832,947; 7,832,948; 7,832,949; 7,832,950; 7,832,951; 7,832,952; 7,832,953; 7,832,954; 7,832,955; 7,832,956; 7,832,957; 7,832,958; 7,832,959; 7,832,960; 7,832,961; 7,832,962; 7,832,963; 7,832,964; 7,832,965; 7,832,966; 7,832,967; 7,832,968; 7,832,969; 7,832,970; 7,832,971; 7,832,972; 7,832,973; 7,832,974; 7,832,975; 7,832,976; 7,832,977; 7,832,978; 7,832,979; 7,832,980; 7,832,981; 7,832,982; 7,832,983; 7,832,984; 7,832,985; 7,832,986; 7,832,987; 7,832,988; 7,832,989; 7,832,990; 7,832,991; 7,832,992; 7,832,993; 7,832,994; 7,832,995; 7,832,996; 7,832,997; 7,832,998; 7,832,999; 7,832,1000.

PROPRIETARY AND CONFIDENTIAL:
THE INFORMATION CONTAINED IN THIS DRAWING IS THE SOLE PROPERTY OF MWS. NO PART OF THIS DRAWING IS TO BE REPRODUCED OR TRANSMITTED IN ANY FORM OR BY ANY MEANS, ELECTRONIC OR MECHANICAL, INCLUDING PHOTOCOPYING, RECORDING, OR BY ANY INFORMATION STORAGE AND RETRIEVAL SYSTEM, WITHOUT THE WRITTEN PERMISSION OF MWS. © 2016 MWS. ALL RIGHTS RESERVED.



www.mws-wetlands.com | 800.860.0117

SITE SPECIFIC DATA

PROJECT NUMBER	
PROJECT NAME	
PROJECT LOCATION	
STRUCTURE ID	
TREATMENT REQUIRED	
VOLUME BASED (CFS)	FLOW BASED (CFS)
TREATMENT HOL. AVAILABLE (FT)	
PEAK BYPASS REQUIRED (CFS) - IF APPLICABLE	
PIPE DATA	IE MATERIAL DIAMETER
INLET PIPE 1	
INLET PIPE 2	
OUTLET PIPE	
PRETREATMENT	BIOFILTRATION DISCHARGE
RIM ELEVATION	
SURFACE LOAD	PARKWAY OPEN PAVEMENT PARKWAY
FRAME & COVER	3 EA Ø30" N/A Ø24"
WETLAND MEDIA VOLUME (CY)	TBD
WETLAND MEDIA DELIVERY METHOD	PER CONTRACT
ORIFICE SIZE (ØA, INCHES)	TBD
NOTES:	

INSTALLATION NOTES

- CONTRACTOR TO PROVIDE ALL LABOR, EQUIPMENT, MATERIALS AND INCIDENTALS REQUIRED TO OFFLOAD AND INSTALL THE STRUTTED AND APPURTENANCES IN ACCORDANCE WITH THIS DRAWING AND THE MANUFACTURERS SPECIFICATIONS, UNLESS OTHERWISE STATED IN MANUFACTURERS CONTRACT.
- UNIT MUST BE INSTALLED ON LEVEL BASE. MANUFACTURER RECOMMENDS A MINIMUM 6" LEVEL ROCK BASE UNLESS SPECIFIED BY THE PROJECT ENGINEER. CONTRACTOR IS RESPONSIBLE TO VERIFY PROJECT ENGINEERS RECOMMENDED BASE SPECIFICATIONS.
- ALL PIPES MUST BE FLUSH WITH INSIDE SURFACE OF CONCRETE (PIPES CANNOT INTRUDE BEYOND FLUSH). INVERT OF OUTFLOW PIPE MUST BE FLUSH WITH DISCHARGE CHAMBER FLOOR. ALL GAPS AROUND PIPES SHALL BE SEALED WATER TIGHT WITH A NON-SHRINK GROUT PER MANUFACTURERS STANDARD CONNECTION DETAIL AND SHALL MEET OR EXCEED REGIONAL PIPE CONNECTION STANDARDS.
- CONTRACTOR TO SUPPLY AND INSTALL ALL EXTERNAL CONNECTING PIPES.
- CONTRACTOR RESPONSIBLE FOR INSTALLATION OF ALL RISERS, MANHOLES AND HATCHES. CONTRACTOR TO GROUT ALL MANHOLES AND HATCHES TO MATCH FINISHED SURFACE UNLESS SPECIFIED OTHERWISE. DRIP OR SPRAY IRRIGATION REQUIRED ON ALL UNITS WITH VEGETATION. CONTRACTOR RESPONSIBLE FOR CONTRACTING MODULAR WETLANDS FOR ACTIVATION OF UNIT. MANUFACTURERS WARRANTY IS VOID WITH OUT PROPER ACTIVATION BY A MODULAR WETLANDS REPRESENTATIVE.

GENERAL NOTES

- MANUFACTURER TO PROVIDE ALL MATERIALS UNLESS OTHERWISE NOTED.
- ALL DIMENSIONS, ELEVATIONS, SPECIFICATIONS AND CAPACITIES ARE SUBJECT TO CHANGE. FOR PROJECT SPECIFIC DRAWINGS DETAILING EXACT DIMENSIONS, WEIGHTS AND ACCESSORIES PLEASE CONTACT MANUFACTURER.

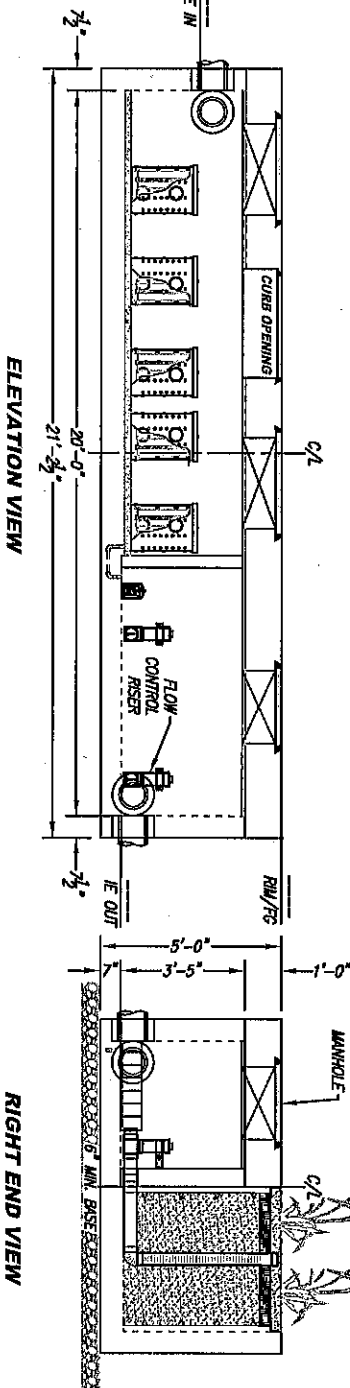
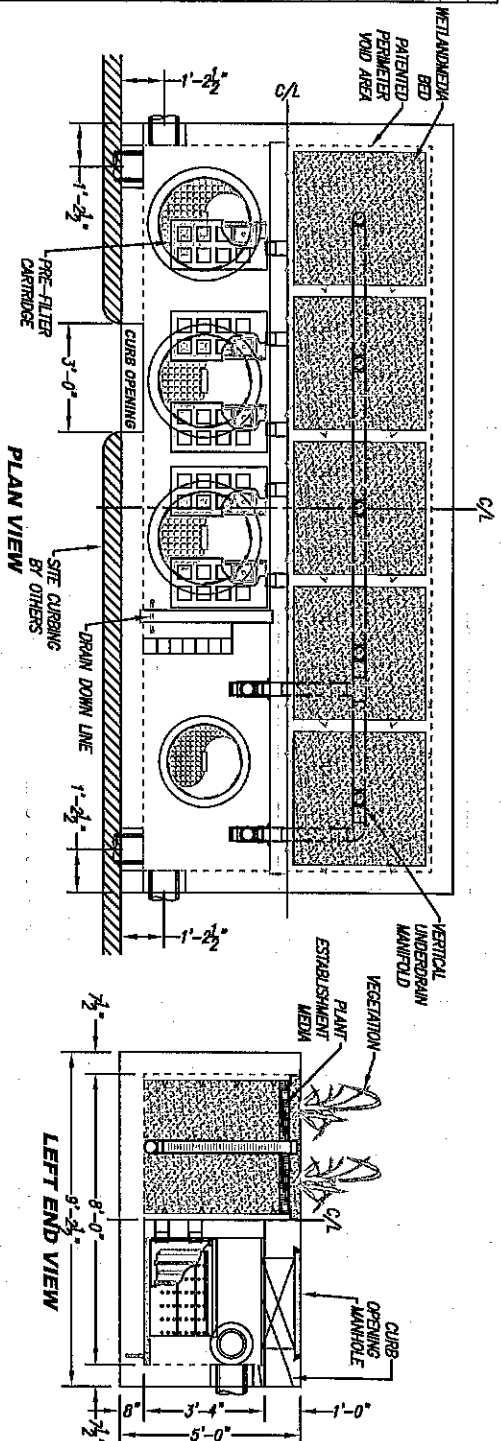

THE PRODUCT DESCRIBED MAY BE THE PROPERTY OF ONE OR MORE OF THE MANUFACTURERS OF THIS SYSTEM. ANY REPRODUCTION IN PART OR AS A WHOLE WITHOUT THE WRITTEN PERMISSION OF MODULAR WETLANDS SYSTEMS IS PROHIBITED.



TREATMENT FLOW (CFS)	0.577
OPERATING HEAD (FT)	3.4
PRETREATMENT LOADING RATE (GPM/SF)	2.0
WETLAND MEDIA LOADING RATE (GPM/SF)	1.0

MWS-1-8-20-C
STORMWATER BIOFILTRATION SYSTEM
STANDARD DETAIL

SITE SPECIFIC DATA

PROJECT NAME	
PROJECT LOCATION	
STRUCTURE ID	TREATMENT REQUIRED
VOLUME BASED (CF)	FLOW BASED (GFS)
TREATMENT HD. AVAILABLE (FT)	
PEAK BRASS REQUIRED (GFS) - IF APPLICABLE	
PIPE DATA	IE MATERIAL DIAMETER
INLET PIPE 1	
INLET PIPE 2	
OUTLET PIPE	
PRETREATMENT	BIOFILTRATION
DISCHARGE	
RIM ELEVATION	
PARKWAY	OPEN PLANTER
FRAME & COVER	PARAWAY
WETLAND MEDIA VOLUME (CY)	11.85
WETLAND MEDIA DELIVERY METHOD	TBD
ORifice SIZE (O.D. INCHES)	Ø2.43"
MAXIMUM PICK WEIGHT (LBS)	TBD

NOTES

INSTALLATION NOTES

- CONTRACTOR TO PROVIDE ALL LABOR, EQUIPMENT, MATERIALS AND ACCESSORIES REQUIRED TO OFFLOAD AND INSTALL THE SYSTEM AND MANUFACTURERS SPECIFICATIONS, UNLESS OTHERWISE STATED IN MANUFACTURERS CONTRACT.
- UNIT MUST BE INSTALLED ON LEVEL BASE. MANUFACTURER RECOMMENDS A MINIMUM 6" LEVEL ROCK BASE UNLESS SPECIFIED BY THE PROJECT ENGINEER. CONTRACTOR IS RESPONSIBLE TO VERIFY PROJECT ENGINEER'S RECOMMENDED BASE SPECIFICATIONS.
- ALL PIPES MUST BE FLUSH WITH INSIDE SURFACE OF CONCRETE (PIPES CANNOT INTRUDE BEYOND FLUSH). INVERT OF OUTFLOW PIPE MUST BE FLUSH WITH DISCHARGE CHAMBER FLOOR. ALL GAPS AROUND PIPES SHALL BE SEALED WATER TIGHT WITH A NON-SHRINK GROUT PER MANUFACTURERS STANDARD CONNECTION DETAIL AND SHALL MEET OR EXCEED REGIONAL PIPE CONNECTION STRADDLES.
- CONTRACTOR TO SUPPLY AND INSTALL ALL EXTERNAL CONNECTING PIPES.
- CONTRACTOR RESPONSIBLE FOR INSTALLATION OF ALL RISERS, MANHOLES AND HATCHES. CONTRACTOR TO GROUT ALL MANHOLES AND HATCHES TO MATCH FINISHED SURFACE UNLESS SPECIFIED OTHERWISE.
- DRIP OR SPRAY IRRIGATION REQUIRED ON ALL UNITS WITH VEGETATION.

GENERAL NOTES

- MANUFACTURER TO PROVIDE ALL MATERIALS UNLESS OTHERWISE NOTED.
- ALL DIMENSIONS, ELEVATIONS, SPECIFICATIONS AND CAPACITIES ARE SUBJECT TO CHANGE FOR PROJECT SPECIFIC DRAWINGS DETAILING EXACT DIMENSIONS, HEIGHTS AND ACCESSORIES PLEASE CONTACT MANUFACTURER.

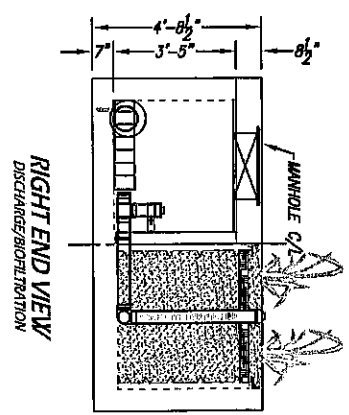
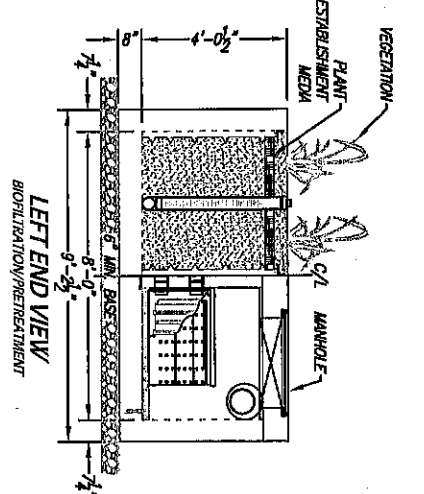
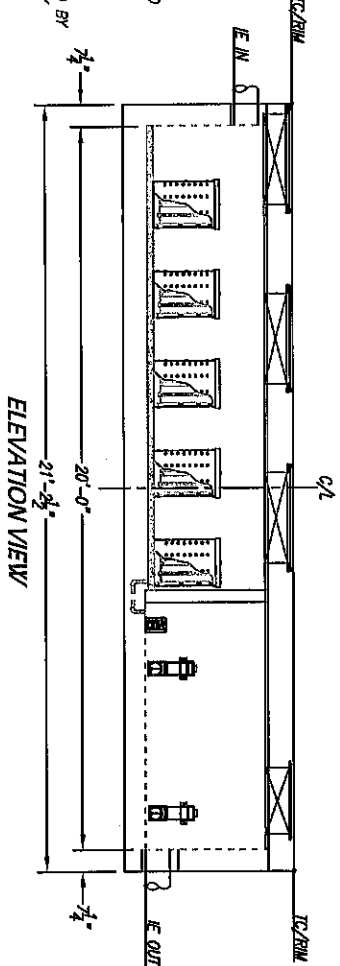
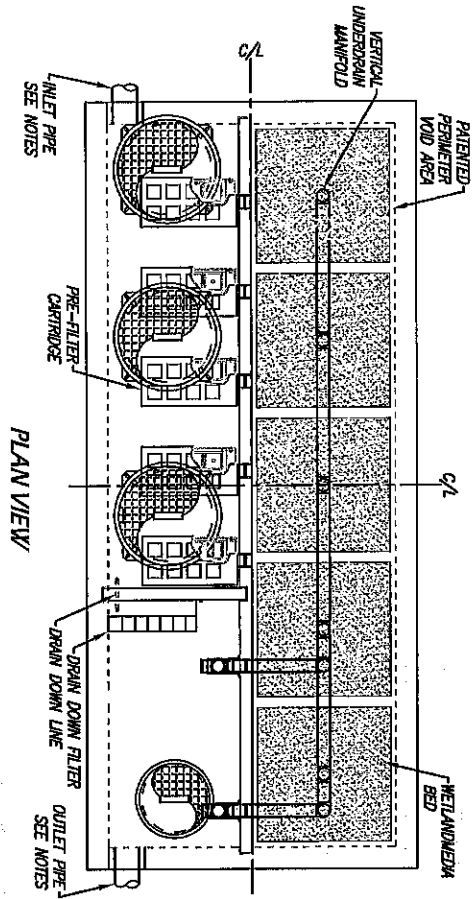

THE PRODUCT DESCRIBED MAY BE PROTECTED BY ONE OR MORE OF THE FOLLOWING US PATENTS: 7,832,812; 7,832,813; 7,832,814; 7,832,815; 7,832,816; 7,832,817; 7,832,818; 7,832,819; 7,832,820; 7,832,821; 7,832,822; 7,832,823; 7,832,824; 7,832,825; 7,832,826; 7,832,827; 7,832,828; 7,832,829; 7,832,830; 7,832,831; 7,832,832; 7,832,833; 7,832,834; 7,832,835; 7,832,836; 7,832,837; 7,832,838; 7,832,839; 7,832,840; 7,832,841; 7,832,842; 7,832,843; 7,832,844; 7,832,845; 7,832,846; 7,832,847; 7,832,848; 7,832,849; 7,832,850; 7,832,851; 7,832,852; 7,832,853; 7,832,854; 7,832,855; 7,832,856; 7,832,857; 7,832,858; 7,832,859; 7,832,860; 7,832,861; 7,832,862; 7,832,863; 7,832,864; 7,832,865; 7,832,866; 7,832,867; 7,832,868; 7,832,869; 7,832,870; 7,832,871; 7,832,872; 7,832,873; 7,832,874; 7,832,875; 7,832,876; 7,832,877; 7,832,878; 7,832,879; 7,832,880; 7,832,881; 7,832,882; 7,832,883; 7,832,884; 7,832,885; 7,832,886; 7,832,887; 7,832,888; 7,832,889; 7,832,890; 7,832,891; 7,832,892; 7,832,893; 7,832,894; 7,832,895; 7,832,896; 7,832,897; 7,832,898; 7,832,899; 7,832,900; 7,832,901; 7,832,902; 7,832,903; 7,832,904; 7,832,905; 7,832,906; 7,832,907; 7,832,908; 7,832,909; 7,832,910; 7,832,911; 7,832,912; 7,832,913; 7,832,914; 7,832,915; 7,832,916; 7,832,917; 7,832,918; 7,832,919; 7,832,920; 7,832,921; 7,832,922; 7,832,923; 7,832,924; 7,832,925; 7,832,926; 7,832,927; 7,832,928; 7,832,929; 7,832,930; 7,832,931; 7,832,932; 7,832,933; 7,832,934; 7,832,935; 7,832,936; 7,832,937; 7,832,938; 7,832,939; 7,832,940; 7,832,941; 7,832,942; 7,832,943; 7,832,944; 7,832,945; 7,832,946; 7,832,947; 7,832,948; 7,832,949; 7,832,950; 7,832,951; 7,832,952; 7,832,953; 7,832,954; 7,832,955; 7,832,956; 7,832,957; 7,832,958; 7,832,959; 7,832,960; 7,832,961; 7,832,962; 7,832,963; 7,832,964; 7,832,965; 7,832,966; 7,832,967; 7,832,968; 7,832,969; 7,832,970; 7,832,971; 7,832,972; 7,832,973; 7,832,974; 7,832,975; 7,832,976; 7,832,977; 7,832,978; 7,832,979; 7,832,980; 7,832,981; 7,832,982; 7,832,983; 7,832,984; 7,832,985; 7,832,986; 7,832,987; 7,832,988; 7,832,989; 7,832,990; 7,832,991; 7,832,992; 7,832,993; 7,832,994; 7,832,995; 7,832,996; 7,832,997; 7,832,998; 7,832,999; 7,833,000.

PROPRIETARY AND CONFIDENTIAL. THE INFORMATION CONTAINED IN THIS DRAWING IS THE SOLE PROPERTY OF WETLANDS. REPRODUCTION IN WHOLE OR IN PART WITHOUT THE WRITTEN PERMISSION OF WETLANDS IS PROHIBITED.



TREATMENT FLOW (GFS)	0.577
OPERATING HEAD (FT)	3.4
PRETREATMENT LOADING RATE (GPM/SF)	TBD
WETLAND MEDIA LOADING RATE (GPM/SF)	1.0

MW-5-1-8-20-V
STORMWATER BIOFILTRATION SYSTEM
STANDARD DETAIL

SITE SPECIFIC DATA					
PROJECT NUMBER					
PROJECT NAME					
PROJECT LOCATION					
STRUCTURE ID					
TREATMENT REQUIRED					
VOLUME BASED (CFS)	FLOW BASED (CFS)				
TREATMENT HQL AVAILABLE (FT)					
PEAK BYPASS REQUIRED (CFS) - IF APPLICABLE					
PIPE DATA	LE	MATERIAL	PVC	DIAMETER	8"
INLET PIPE 1			N/A		N/A
INLET PIPE 2			N/A		N/A
OUTLET PIPE			PVC		8"
PRETREATMENT			BIOFILTRATION		DISCHARGE
RAW ELEVATION	PARKWAY	OPEN PAVEMENT			PARKWAY
SURFACE LOAD					
FRAME & COVER	3 EA 830"	N/A			2 EA 824"
WETLAND MEDIA VOLUME (CY)					TBD
WETLAND MEDIA DELIVERY METHOD					PER CONTRACT
ORIFICE SIZE (DIA. INCHES)					TBD
NOTES					

INSTALLATION NOTES

- CONTRACTOR TO PROVIDE ALL LABOR, EQUIPMENT, MATERIALS AND INCIDENTALS REQUIRED TO OFFLOAD AND INSTALL THE SYSTEM AND APPEARANCES IN ACCORDANCE WITH THIS DRAWING AND THE MANUFACTURERS SPECIFICATIONS, UNLESS OTHERWISE STATED IN MANUFACTURERS CONTRACT.
- UNIT MUST BE INSTALLED ON LEVEL BASE. MANUFACTURER RECOMMENDS A MINIMUM 6" LEVEL ROCK BASE UNLESS SPECIFIED BY THE PROJECT ENGINEER. CONTRACTOR IS RESPONSIBLE TO VERIFY PROJECT ENGINEERS RECOMMENDED BASE SPECIFICATIONS.
- ALL PIPES MUST BE FLUSH WITH INSIDE SURFACE OF CONCRETE IE IN (PIPS CANNOT INTRUDE BEYOND FLUSH). INVERT OF OUTFLOW PIPE MUST BE FLUSH WITH DISCHARGE CHAMBER FLOOR. ALL GAPS AROUND PIPES SHALL BE SEALED WATER TIGHT WITH A NON-SHRINK GROUT PER MANUFACTURERS STANDARD CONNECTION DETAIL AND SHALL MEET OR EXCEED REGIONAL PIPE CONNECTION STANDARDS.
- CONTRACTOR TO SUPPLY AND INSTALL ALL EXTERNAL CONNECTING PIPES.
- CONTRACTOR RESPONSIBLE FOR INSTALLATION OF ALL RISERS, MANHOLES, AND HATCHES. CONTRACTOR TO GROUT ALL MANHOLES AND HATCHES TO MATCH FINISHED SURFACE UNLESS SPECIFIED OTHERWISE. DRIP OR SPRAY IRRIGATION REQUIRED ON ALL UNITS WITH VEGETATION. CONTRACTOR RESPONSIBLE FOR CONTRACTING MODULAR WETLANDS FOR ACTIVATION OF UNIT. MANUFACTURERS WARRANTY IS VOID WITH OUT PROPER ACTIVATION BY A MODULAR WETLANDS REPRESENTATIVE.

GENERAL NOTES

- MANUFACTURER TO PROVIDE ALL MATERIALS UNLESS OTHERWISE NOTED.
- ALL DIMENSIONS, ELEVATIONS, SPECIFICATIONS AND CAPACITIES ARE SUBJECT TO CHANGE. FOR PROJECT SPECIFIC DRAWINGS DETAILING EXACT DIMENSIONS, WEIGHTS AND ACCESSORIES PLEASE CONTACT MANUFACTURER.

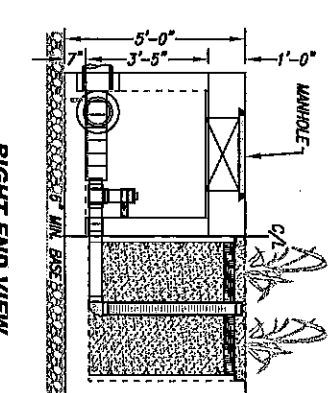
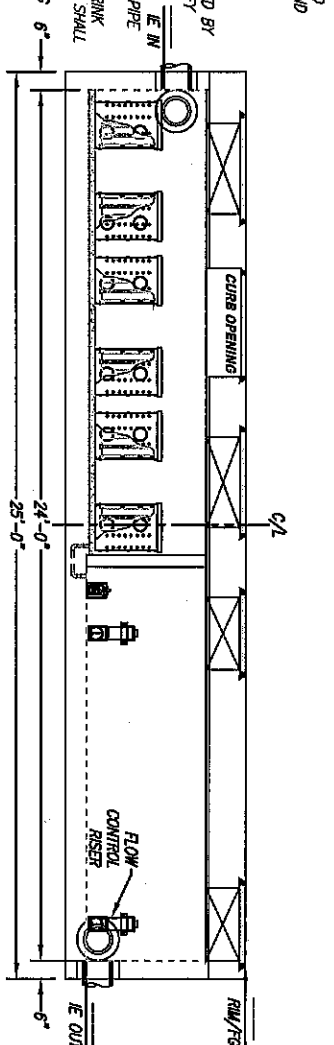
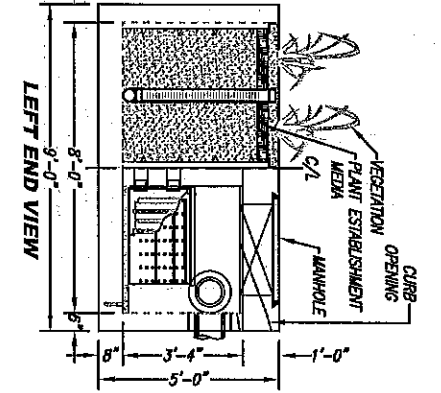
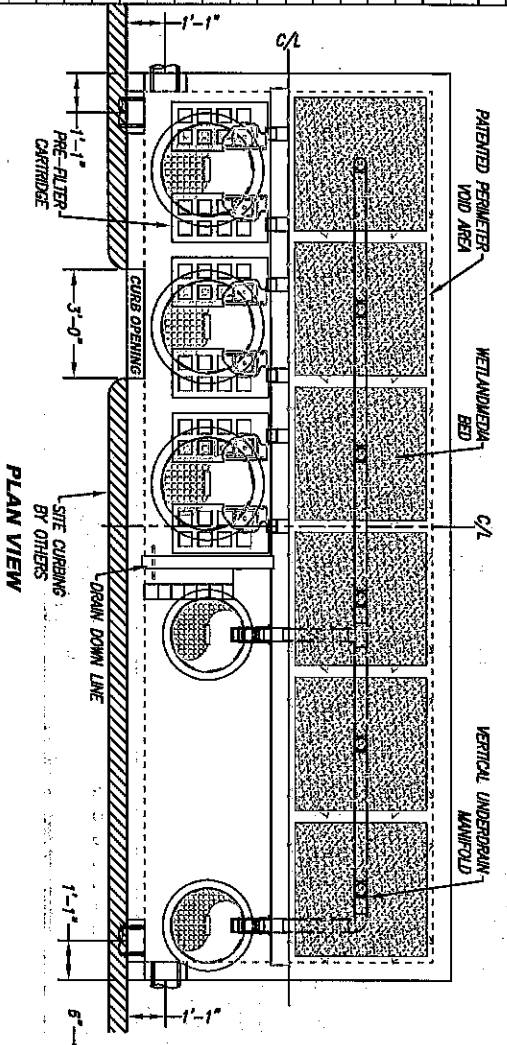

TREATMENT FLOW (CFS)	0.693
OPERATING HEAD (FT)	3.4
PRETREATMENT LOADING RATE (GPM/SF)	2.0
WETLAND MEDIA LOADING RATE (GPM/SF)	1.0

MWS-L-8-24-C
STORMWATER BIOFILTRATION SYSTEM
STANDARD DETAIL

THE PRODUCT DESCRIBED MAY BE THE PROPERTY OF THE MANUFACTURER. THE INFORMATION CONTAINED IN THIS DRAWING IS THE SOLE PROPERTY OF MODULAR WETLANDS SYSTEMS, INC. REPRODUCTION IN WHOLE OR IN PART WITHOUT THE WRITTEN PERMISSION OF MODULAR WETLANDS SYSTEMS IS PROHIBITED.

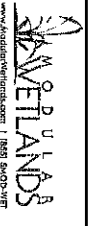

www.modularwetlands.com 1 800 800 0011

SITE SPECIFIC DATA	
PROJECT NUMBER	
PROJECT NAME	
PROJECT LOCATION	
STRUCTURE ID	
TREATMENT REQUIRED	
VOLUME BASED (CF)	FLOW BASED (CFS)
TREATMENT HGL AVAILABLE (FT)	
PEAK BYPASS REQUIRED (CFS) - IF APPLICABLE	
PIPE DATA	LE MATERIAL DIAMETER
INLET PIPE 1	PVC 8"
INLET PIPE 2	N/A N/A
OUTLET PIPE	PVC 8"
PRETREATMENT	BIOFILTRATION DISCHARGE
RIM ELEVATION	
SURFACE LOAD	PARKWAY OPEN PLAYERS PARKWAY
FRAME & COVER	3 EA #30" N/A 2 EA #24"
WETLAND MEDIA VOLUME (CY)	TBD
WETLAND MEDIA DELIVERY METHOD	PER CONTRACT
ORIFICE SIZE (DIA. INCHES)	TBD
NOTES:	

INSTALLATION NOTES

- CONTRACTOR TO PROVIDE ALL LABOR, EQUIPMENT, MATERIALS AND INCIDENTALS REQUIRED TO OFFLOAD AND INSTALL THE SYSTEM AND APPURTENANCES IN ACCORDANCE WITH THIS DRAWING AND THE MANUFACTURERS SPECIFICATIONS, UNLESS OTHERWISE STATED IN MANUFACTURERS CONTRACT.
- RECOMMENDS A MINIMUM 6" LEVEL ROCK BASE UNLESS SPECIFIED BY THE PROJECT ENGINEER. CONTRACTOR IS RESPONSIBLE TO VERIFY PROJECT ENGINEERS RECOMMENDED BASE SPECIFICATIONS.
- ALL PIPES MUST BE FLUSH WITH INSIDE SURFACE OF CONCRETE. IE IN (PIPES CANNOT INTRUDE BEYOND FLUSH). INVERT OF OUTFLOW PIPE MUST BE FLUSH WITH DISCHARGE CHAMBER FLOOR. ALL GAPS AROUND PIPES SHALL BE SEALED WATER TIGHT WITH A NON-SHRINK GROUT PER MANUFACTURERS STANDARD CONNECTION DETAIL AND SHALL MEET OR EXCEED REGIONAL PIPE CONNECTION STANDARDS.
- CONTRACTOR TO SUPPLY AND INSTALL ALL EXTERNAL CONNECTING PIPES.
- CONTRACTOR RESPONSIBLE FOR INSTALLATION OF ALL RISERS, MANHOLES, AND HATCHES. CONTRACTOR TO GROUT ALL MANHOLES AND HATCHES TO MATCH FINISHED SURFACE UNLESS SPECIFIED OTHERWISE.
- DRIP OR SPRAY IRRIGATION REQUIRED ON ALL UNITS WITH VEGETATION. CONTRACTOR RESPONSIBLE FOR CONDUCTING MODULAR WETLANDS FOR ACTIVATION OF UNIT. MANUFACTURERS WARRANTY IS VOID WITH OUT PROPER ACTIVATION BY A MODULAR WETLANDS REPRESENTATIVE.

GENERAL NOTES

- MANUFACTURER TO PROVIDE ALL MATERIALS UNLESS OTHERWISE NOTED.
- ALL DIMENSIONS, ELEVATIONS, SPECIFICATIONS AND CAPACITIES ARE SUBJECT TO CHANGE FOR PROJECT SPECIFIC DRAWINGS DETAILING EXACT DIMENSIONS, WEIGHTS AND ACCESSORIES PLEASE CONTACT MANUFACTURER.

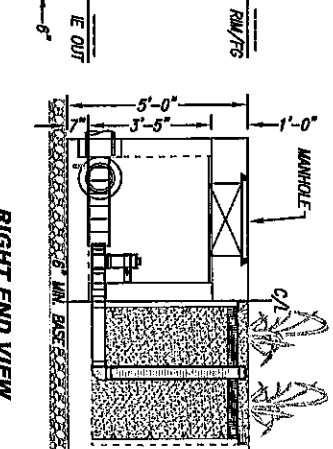
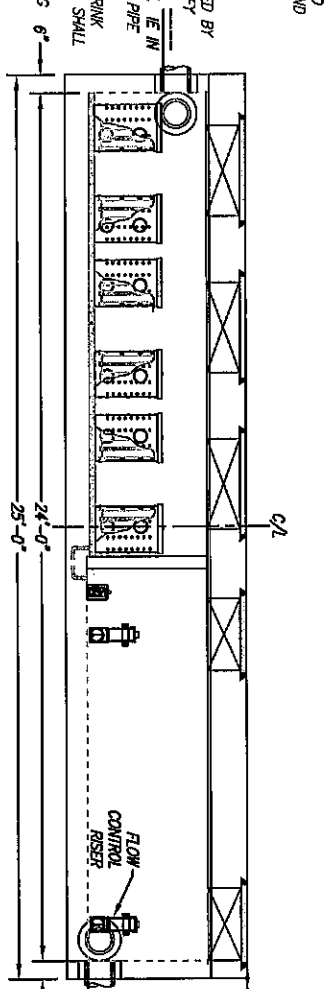
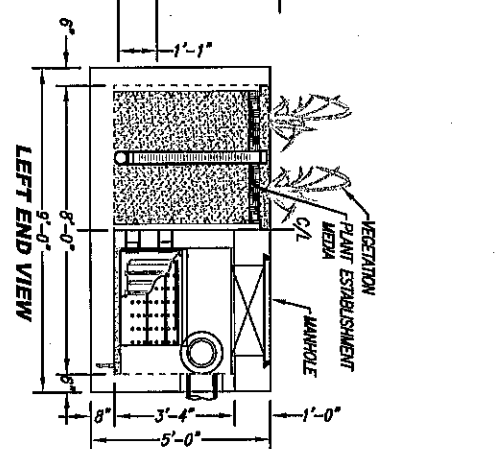
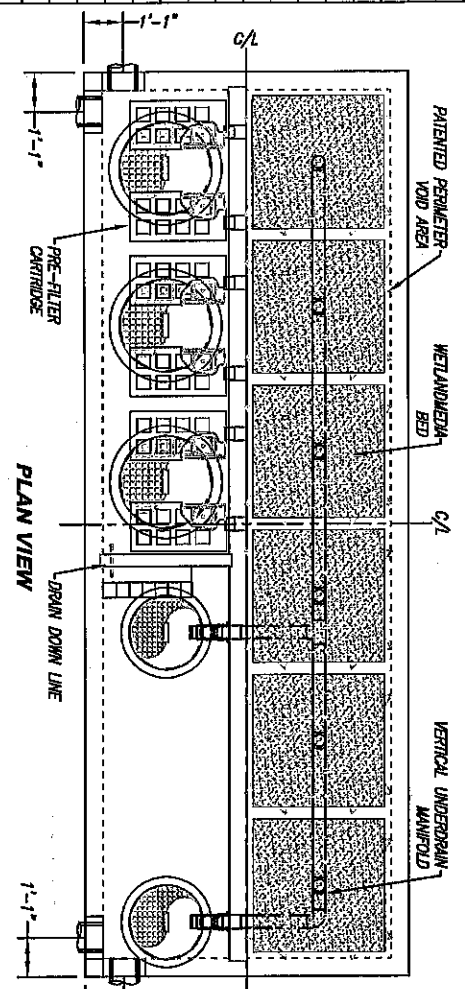

THE PRODUCT DESCRIBED MAY BE PATENTED BY ONE OR MORE OF THE FOLLOWING US PATENTS: 7,812,411; 7,812,412; 7,812,413; 7,812,414; 7,812,415; 7,812,416; 7,812,417; 7,812,418; 7,812,419; 7,812,420; 7,812,421; 7,812,422; 7,812,423; 7,812,424; 7,812,425; 7,812,426; 7,812,427; 7,812,428; 7,812,429; 7,812,430; 7,812,431; 7,812,432; 7,812,433; 7,812,434; 7,812,435; 7,812,436; 7,812,437; 7,812,438; 7,812,439; 7,812,440; 7,812,441; 7,812,442; 7,812,443; 7,812,444; 7,812,445; 7,812,446; 7,812,447; 7,812,448; 7,812,449; 7,812,450; 7,812,451; 7,812,452; 7,812,453; 7,812,454; 7,812,455; 7,812,456; 7,812,457; 7,812,458; 7,812,459; 7,812,460; 7,812,461; 7,812,462; 7,812,463; 7,812,464; 7,812,465; 7,812,466; 7,812,467; 7,812,468; 7,812,469; 7,812,470; 7,812,471; 7,812,472; 7,812,473; 7,812,474; 7,812,475; 7,812,476; 7,812,477; 7,812,478; 7,812,479; 7,812,480; 7,812,481; 7,812,482; 7,812,483; 7,812,484; 7,812,485; 7,812,486; 7,812,487; 7,812,488; 7,812,489; 7,812,490; 7,812,491; 7,812,492; 7,812,493; 7,812,494; 7,812,495; 7,812,496; 7,812,497; 7,812,498; 7,812,499; 7,812,500; 7,812,501; 7,812,502; 7,812,503; 7,812,504; 7,812,505; 7,812,506; 7,812,507; 7,812,508; 7,812,509; 7,812,510; 7,812,511; 7,812,512; 7,812,513; 7,812,514; 7,812,515; 7,812,516; 7,812,517; 7,812,518; 7,812,519; 7,812,520; 7,812,521; 7,812,522; 7,812,523; 7,812,524; 7,812,525; 7,812,526; 7,812,527; 7,812,528; 7,812,529; 7,812,530; 7,812,531; 7,812,532; 7,812,533; 7,812,534; 7,812,535; 7,812,536; 7,812,537; 7,812,538; 7,812,539; 7,812,540; 7,812,541; 7,812,542; 7,812,543; 7,812,544; 7,812,545; 7,812,546; 7,812,547; 7,812,548; 7,812,549; 7,812,550; 7,812,551; 7,812,552; 7,812,553; 7,812,554; 7,812,555; 7,812,556; 7,812,557; 7,812,558; 7,812,559; 7,812,560; 7,812,561; 7,812,562; 7,812,563; 7,812,564; 7,812,565; 7,812,566; 7,812,567; 7,812,568; 7,812,569; 7,812,570; 7,812,571; 7,812,572; 7,812,573; 7,812,574; 7,812,575; 7,812,576; 7,812,577; 7,812,578; 7,812,579; 7,812,580; 7,812,581; 7,812,582; 7,812,583; 7,812,584; 7,812,585; 7,812,586; 7,812,587; 7,812,588; 7,812,589; 7,812,590; 7,812,591; 7,812,592; 7,812,593; 7,812,594; 7,812,595; 7,812,596; 7,812,597; 7,812,598; 7,812,599; 7,812,600; 7,812,601; 7,812,602; 7,812,603; 7,812,604; 7,812,605; 7,812,606; 7,812,607; 7,812,608; 7,812,609; 7,812,610; 7,812,611; 7,812,612; 7,812,613; 7,812,614; 7,812,615; 7,812,616; 7,812,617; 7,812,618; 7,812,619; 7,812,620; 7,812,621; 7,812,622; 7,812,623; 7,812,624; 7,812,625; 7,812,626; 7,812,627; 7,812,628; 7,812,629; 7,812,630; 7,812,631; 7,812,632; 7,812,633; 7,812,634; 7,812,635; 7,812,636; 7,812,637; 7,812,638; 7,812,639; 7,812,640; 7,812,641; 7,812,642; 7,812,643; 7,812,644; 7,812,645; 7,812,646; 7,812,647; 7,812,648; 7,812,649; 7,812,650; 7,812,651; 7,812,652; 7,812,653; 7,812,654; 7,812,655; 7,812,656; 7,812,657; 7,812,658; 7,812,659; 7,812,660; 7,812,661; 7,812,662; 7,812,663; 7,812,664; 7,812,665; 7,812,666; 7,812,667; 7,812,668; 7,812,669; 7,812,670; 7,812,671; 7,812,672; 7,812,673; 7,812,674; 7,812,675; 7,812,676; 7,812,677; 7,812,678; 7,812,679; 7,812,680; 7,812,681; 7,812,682; 7,812,683; 7,812,684; 7,812,685; 7,812,686; 7,812,687; 7,812,688; 7,812,689; 7,812,690; 7,812,691; 7,812,692; 7,812,693; 7,812,694; 7,812,695; 7,812,696; 7,812,697; 7,812,698; 7,812,699; 7,812,700; 7,812,701; 7,812,702; 7,812,703; 7,812,704; 7,812,705; 7,812,706; 7,812,707; 7,812,708; 7,812,709; 7,812,710; 7,812,711; 7,812,712; 7,812,713; 7,812,714; 7,812,715; 7,812,716; 7,812,717; 7,812,718; 7,812,719; 7,812,720; 7,812,721; 7,812,722; 7,812,723; 7,812,724; 7,812,725; 7,812,726; 7,812,727; 7,812,728; 7,812,729; 7,812,730; 7,812,731; 7,812,732; 7,812,733; 7,812,734; 7,812,735; 7,812,736; 7,812,737; 7,812,738; 7,812,739; 7,812,740; 7,812,741; 7,812,742; 7,812,743; 7,812,744; 7,812,745; 7,812,746; 7,812,747; 7,812,748; 7,812,749; 7,812,750; 7,812,751; 7,812,752; 7,812,753; 7,812,754; 7,812,755; 7,812,756; 7,812,757; 7,812,758; 7,812,759; 7,812,760; 7,812,761; 7,812,762; 7,812,763; 7,812,764; 7,812,765; 7,812,766; 7,812,767; 7,812,768; 7,812,769; 7,812,770; 7,812,771; 7,812,772; 7,812,773; 7,812,774; 7,812,775; 7,812,776; 7,812,777; 7,812,778; 7,812,779; 7,812,780; 7,812,781; 7,812,782; 7,812,783; 7,812,784; 7,812,785; 7,812,786; 7,812,787; 7,812,788; 7,812,789; 7,812,790; 7,812,791; 7,812,792; 7,812,793; 7,812,794; 7,812,795; 7,812,796; 7,812,797; 7,812,798; 7,812,799; 7,812,800; 7,812,801; 7,812,802; 7,812,803; 7,812,804; 7,812,805; 7,812,806; 7,812,807; 7,812,808; 7,812,809; 7,812,810; 7,812,811; 7,812,812; 7,812,813; 7,812,814; 7,812,815; 7,812,816; 7,812,817; 7,812,818; 7,812,819; 7,812,820; 7,812,821; 7,812,822; 7,812,823; 7,812,824; 7,812,825; 7,812,826; 7,812,827; 7,812,828; 7,812,829; 7,812,830; 7,812,831; 7,812,832; 7,812,833; 7,812,834; 7,812,835; 7,812,836; 7,812,837; 7,812,838; 7,812,839; 7,812,840; 7,812,841; 7,812,842; 7,812,843; 7,812,844; 7,812,845; 7,812,846; 7,812,847; 7,812,848; 7,812,849; 7,812,850; 7,812,851; 7,812,852; 7,812,853; 7,812,854; 7,812,855; 7,812,856; 7,812,857; 7,812,858; 7,812,859; 7,812,860; 7,812,861; 7,812,862; 7,812,863; 7,812,864; 7,812,865; 7,812,866; 7,812,867; 7,812,868; 7,812,869; 7,812,870; 7,812,871; 7,812,872; 7,812,873; 7,812,874; 7,812,875; 7,812,876; 7,812,877; 7,812,878; 7,812,879; 7,812,880; 7,812,881; 7,812,882; 7,812,883; 7,812,884; 7,812,885; 7,812,886; 7,812,887; 7,812,888; 7,812,889; 7,812,890; 7,812,891; 7,812,892; 7,812,893; 7,812,894; 7,812,895; 7,812,896; 7,812,897; 7,812,898; 7,812,899; 7,812,900; 7,812,901; 7,812,902; 7,812,903; 7,812,904; 7,812,905; 7,812,906; 7,812,907; 7,812,908; 7,812,909; 7,812,910; 7,812,911; 7,812,912; 7,812,913; 7,812,914; 7,812,915; 7,812,916; 7,812,917; 7,812,918; 7,812,919; 7,812,920; 7,812,921; 7,812,922; 7,812,923; 7,812,924; 7,812,925; 7,812,926; 7,812,927; 7,812,928; 7,812,929; 7,812,930; 7,812,931; 7,812,932; 7,812,933; 7,812,934; 7,812,935; 7,812,936; 7,812,937; 7,812,938; 7,812,939; 7,812,940; 7,812,941; 7,812,942; 7,812,943; 7,812,944; 7,812,945; 7,812,946; 7,812,947; 7,812,948; 7,812,949; 7,812,950; 7,812,951; 7,812,952; 7,812,953; 7,812,954; 7,812,955; 7,812,956; 7,812,957; 7,812,958; 7,812,959; 7,812,960; 7,812,961; 7,812,962; 7,812,963; 7,812,964; 7,812,965; 7,812,966; 7,812,967; 7,812,968; 7,812,969; 7,812,970; 7,812,971; 7,812,972; 7,812,973; 7,812,974; 7,812,975; 7,812,976; 7,812,977; 7,812,978; 7,812,979; 7,812,980; 7,812,981; 7,812,982; 7,812,983; 7,812,984; 7,812,985; 7,812,986; 7,812,987; 7,812,988; 7,812,989; 7,812,990; 7,812,991; 7,812,992; 7,812,993; 7,812,994; 7,812,995; 7,812,996; 7,812,997; 7,812,998; 7,812,999; 7,813,000.



TREATMENT FLOW (CFS)	0.693
OPERATING HEAD (FT)	3.4
PRETREATMENT LOADING RATE (GPM/SF)	2.0
WETLAND MEDIA LOADING RATE (GPM/SF)	1.0

MWS-1-8-24-V
STORMWATER BIOFILTRATION SYSTEM
STANDARD DETAIL

SITE SPECIFIC DATA	
PROJECT NAME	
PROJECT LOCATION	
STRUCTURE ID	
TREATMENT REQUIRED	
VOLUME BASED (CF)	FLOW BASED (CFS)
TREATMENT HQL AVAILABLE (FT)	
PEAK FLOW REQUIRED (CFS) - IF APPLICABLE	
PIPE DATA	IE MATERIAL DIAMETER
INLET PIPE 1	
INLET PIPE 2	
OUTLET PIPE	
PRETREATMENT	BIOFILTRATION DISCHARGE
RIM ELEVATION	PARKWAY OPEN PLANTER
SURFACE LOAD	36" X 36"
FRAME & COVER	14.50
WETLAND MEDIA VOLUME (CY)	TBD
WETLAND MEDIA DELIVERY METHOD	Ø2.67"
ORIFICE SIZE (DIA. INCHES)	TBD
MAXIMUM PICK WEIGHT (LBS)	TBD
NOTES:	

INSTALLATION NOTES

- CONTRACTOR TO PROVIDE ALL LABOR, EQUIPMENT, MATERIALS AND INCIDENTALS REQUIRED TO OFFLOAD AND INSTALL THE SYSTEM AND APPURTENANCES IN ACCORDANCE WITH THIS DRAWING AND THE MANUFACTURER'S SPECIFICATIONS, UNLESS OTHERWISE STATED IN MANUFACTURER'S CONTRACT.
- UNIT MUST BE INSTALLED ON LEVEL BASE. MANUFACTURER RECOMMENDS A MINIMUM 6" LEVEL ROCK BASE UNLESS SPECIFIED BY THE PROJECT ENGINEER. CONTRACTOR IS RESPONSIBLE TO VERIFY PROJECT ENGINEER'S RECOMMENDED BASE SPECIFICATIONS.
- ALL PIPES MUST BE FLUSH WITH INSIDE SURFACE OF CONCRETE. (PIPES CANNOT INTRUDE BEYOND FLUSH). INSET OF OUTFLOW PIPE MUST BE FLUSH WITH DISCHARGE CHAMBER FLOOR. ALL GAPS AROUND PIPES SHALL BE SEALED WATER TIGHT WITH A NON-SHRINK GROUT PER MANUFACTURER'S STANDARD CONNECTION DETAIL AND SHALL MEET OR EXCEED REGIONAL PIPE CONNECTION STANDARDS.
- CONTRACTOR TO SUPPLY AND INSTALL ALL EXTERNAL CONNECTING PIPES.
- CONTRACTOR RESPONSIBLE FOR INSTALLATION OF ALL RISERS, MANHOLES, AND HATCHES. CONTRACTOR TO GROUT ALL MANHOLES AND HATCHES TO MATCH FINISHED SURFACE UNLESS SPECIFIED OTHERWISE.
- DRIP OR SPRAY IRRIGATION REQUIRED ON ALL UNITS WITH VEGETATION.

GENERAL NOTES

- MANUFACTURER TO PROVIDE ALL MATERIALS UNLESS OTHERWISE NOTED.
- ALL DIMENSIONS, ELEVATIONS, SPECIFICATIONS AND CAPACITIES ARE SUBJECT TO CHANGE. FOR PROJECT SPECIFIC DRAWINGS DETAILING EXACT DIMENSIONS, WEIGHTS AND ACCESSORIES PLEASE CONTACT MANUFACTURER.

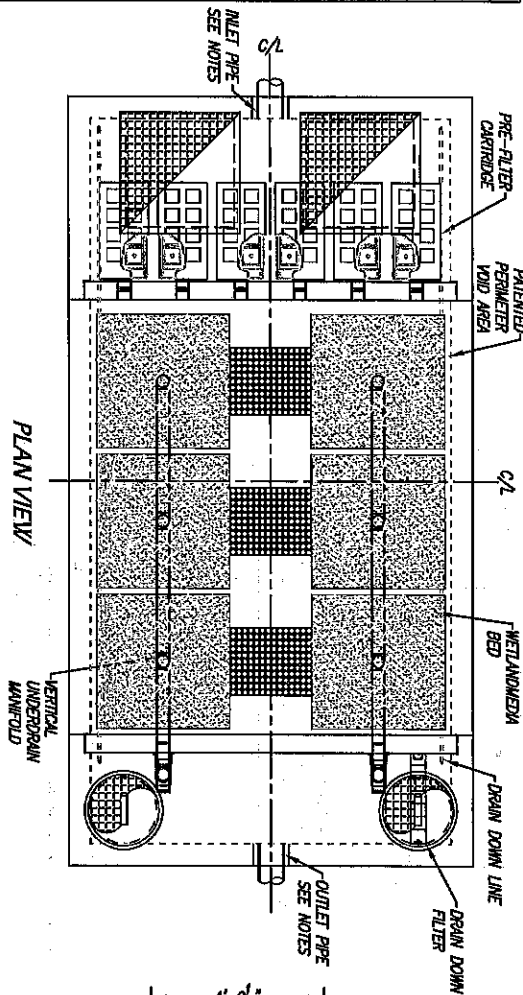

PLAN VIEW

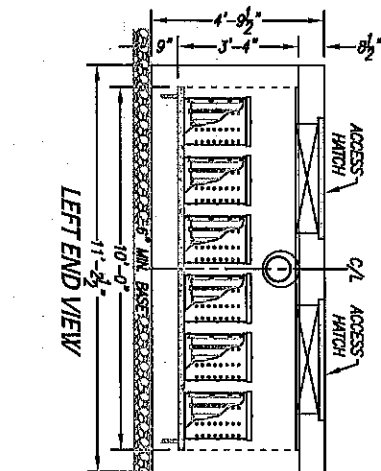

LEFT END VIEW

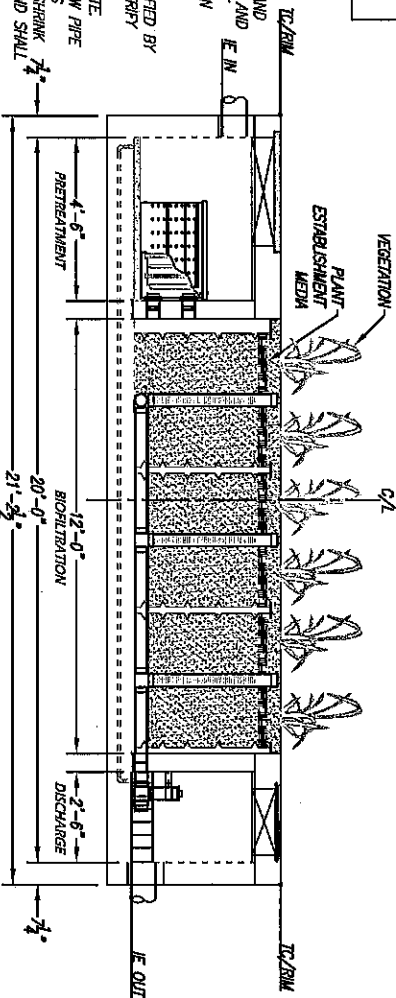

ELEVATION VIEW

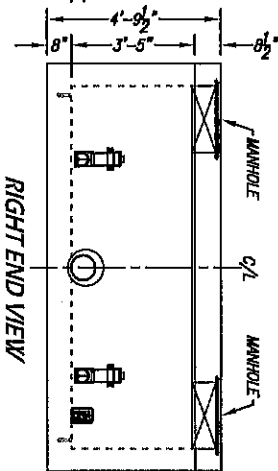

RIGHT END VIEW

THE PRODUCT DESCRIBED MAY BE THE PROPERTY OF THE OR TRADE OR SERVICE MARK OF THE MANUFACTURER. THE REPRODUCTION OF ANY PART OF THIS DRAWING OR AS A WHOLE WITHOUT THE WRITTEN PERMISSION OF WETLANDS SYSTEMS IS PROHIBITED.

PROPRIETARY AND CONFIDENTIAL. THE INFORMATION CONTAINED IN THIS DRAWING IS THE SOLE PROPERTY OF WETLANDS SYSTEMS. ANY REPRODUCTION IN PART OR AS A WHOLE WITHOUT THE WRITTEN PERMISSION OF WETLANDS SYSTEMS IS PROHIBITED.



TREATMENT FLOW (CFS)	0.693
OPERATING HEAD (FT)	3.4
PRETREATMENT LOADING RATE (GPM/SF)	TBD
WETLAND MEDIA LOADING RATE (GPM/SF)	1.0

MWS-L-10-20-V
STORMWATER BIOFILTRATION SYSTEM
STANDARD DETAIL

APPENDIX B

Section [_____]
Modular Subsurface Flow Wetland System

PART 1 – GENERAL

01.01.00 Purpose

The purpose of this specification is to establish generally acceptable criteria for Modular Subsurface Flow Wetland Systems used for biofiltration of stormwater runoff including dry weather flows and other contaminated water sources. It is intended to serve as a guide to producers, distributors, architects, engineers, contractors, plumbers, installers, inspectors, agencies and users; to promote understanding regarding materials, manufacture and installation; and to provide for identification of devices complying with this specification.

01.02.00 Description

Modular Subsurface Flow Wetland Systems (MSFWS) are used for filtration of stormwater runoff including dry weather flows. The MSFWS is a pre-engineered biofiltration system composed of a pretreatment chamber containing filtration cartridges, a horizontal flow biofiltration chamber with a peripheral void area and a centralized and vertically extending underdrain, the biofiltration chamber containing a sorptive media mix which does not contain any organic material and a layer of plant establishment media, and a discharge chamber containing an orifice control structure. Treated water flows horizontally in series through the pretreatment chamber cartridges, biofiltration chamber and orifice control structure.

01.03.00 Manufacturer

The manufacturer of the MSFWS shall be one that is regularly engaged in the engineering design and production of systems developed for the treatment of stormwater runoff for at least (10) years, and which have a history of successful production, acceptable to the engineer of work. In accordance with the drawings, the MSFWS(s) shall be a filter device Manufactured by BioClean A Forterra Company, or assigned distributors or licensees. Bio Clean A Forterra Company, can be reached at:

Headquarters:
Bio Clean A Forterra Company
398 Via El Centro
Oceanside, CA 92058
Phone: (760) 433-7640
Fax: (760) 433-3176
www.biocleanenvironmental.com



A Forterra Company

01.04.00 Submittals

- 01.04.01 Shop drawings are to be submitted with each order to the contractor and consulting engineer.
- 01.04.02 Shop drawings are to detail the MSFWS and all components required and the sequence for installation, including:
 - System configuration with primary dimensions
 - Interior components
 - Any accessory equipment called out on shop drawings
- 01.04.03 Inspection and maintenance documentation submitted upon request.

01.05.00 Work Included

- 01.05.01 Specification requirements for installation of MSFWS.
- 01.05.02 Manufacturer to supply components of the MSFWS(s):
 - Pretreatment chamber components (pre-assembled)
 - Concrete Structure(s)
 - Biofiltration chamber components (pre-assembled)
 - Flow control discharge structure (pre-assembled)

01.06.00 Reference Standards

ASTM C 29	Standard Test Method for Unit Weight and Voids in Aggregate
ASTM C 88	C 88 Standard Test Method for Soundness of Aggregates by Use of Sodium Sulfate or Magnesium Sulfate
ASTM C131	C 131 Standard Test Method for Resistance to Degradation of Small-Size Coarse Aggregates by Abrasion and Impact in the Los Angeles Machine
ASTM C 136	C 136 Standard Test Method for Sieve Analysis of Fine and Coarse Aggregates
ASTM C 330	C 330 Standard Specification for Lightweight Aggregate for Structural Concrete
ASTM D 698	Test Method for Laboratory Compaction Characteristics of Soil Using Standard Effort (12,400 ft.-lbf/ft ³ (600 kN-m/m ³))
ASTM D 1621	10 Standard Test Method for Compressive Properties Of Rigid Cellular Plastics
ASTM D 1777	ASTM D1777 - 96(2007) Standard Test Method for Thickness of Textile Materials
ASTM D 4716	Standard Test Method for Determining the (In-plane) Flow Rate per Unit Width and Hydraulic Transmissivity of a Geosynthetic Using a Constant Head
AASHTO T 99-01	Standard Method of Test for Moisture-Density Relations of Soils Using a 2.5-kg (5.5-lb) Rammer and a 305-mm (12-in) Drop
AASHTO T 104	Standard Method of Test for Soundness of Aggregate by Use of Sodium Sulfate or Magnesium Sulfate
AASHTO T 260	Standard Method of Test for Sampling and Testing for Chloride Ion in Concrete and Concrete Raw Materials.
AASHTO T 288	Standard Method of Test for Determining Minimum Laboratory Soil Resistivity
AASHTO T 289	Standard Method of Test for Determining ph of Soil for Use in Corrosion Testing
AASHTO T 291	Standard Method of Test for Determining Water Soluble Chloride Ion Content in Soil
AASHTO T 290	T 290 Standard Method of Test for Determining Water Soluble Sulfate Ion Content in Soil

PART 2 – COMPONENTS

The Modular Subsurface Flow Wetland Systems (MSFWS) and all of its components shall be self-contained within a concrete structure constructed of concrete with a minimum 28 day compressive strength of 5,000 psi, with reinforcing per ASTM A 615, Grade 60, and supports and H2O loading as indicated by AASHTO. Each Chamber shall have appropriate access hatches for easy maintenance and sized to allow removal of all internal components without disassembly. All water transfer system components shall conform with the following;

- Filter netting shall be 100% Polyester with a number 16 sieve size, and strength tested per ASTM D 3787.
- Drainage cells shall be manufactured of lightweight injection-molded plastic and have a minimum compressive strength test of 6,000 psi and a void area along the surface making contact with the filter media of 75% or greater. The cells shall be at least 2" in thickness and allow water to freely flow in all four directions.

02.01.00 Pretreatment Chamber Components

02.01.01 Filter Cartridges shall operate at a loading rate not to exceed 3 gallons per minute per square foot surface area.

02.01.02 Drain Down System shall include a pervious floor that allows water to drain into the underdrain pipe that is connected to the discharge chamber.

02.02.00 Biofiltration Chamber Components

02.02.01 Media shall consist of ceramic material produced by expanding and vitrifying select material in a rotary kiln. Media must be produced to meet the requirements of ASTM C330, ASTM C331, and AASHTO M195. Aggregates must have a minimum 24-hour water absorption of 10.5% mass. Media shall not contain any organic material. Flow through media shall be horizontal from the outer perimeter of the chamber toward the centralized and vertically extending underdrain. The retention time in the media shall be at least 3 minutes. Downward flow filters are not acceptable alternatives. The thickness of the media shall be at least 19" from influent end to effluent end. The loading rate on the media shall not exceed 1.1 gallons per minute per square foot surface area. Media must be contained within structure that spaces the surface of the media at least 2" from all vertically extending walls of the concrete structure.

02.02.02 Planting shall be native, drought tolerant species recommend by manufacturer and/or landscape architect.

02.02.03 Plant Support Media shall be made of a 3" thick moisture retention cell that is inert and contains no chemicals or fertilizers, is not made of organic material and has an internal void percentage of 80%.

02.03.00 Discharge Chamber

The discharge device shall house a flow control orifice plate that restricts flows greater than designed treatment flow rate. All piping components shall be made of a high-density polyethylene. The discharge chamber shall also contain a drain down filter if specified on the drawing.

PART 3 – PERFORMANCE

03.01.00 General

03.01.01

Function - The MSFWS has no moving internal components and functions based on gravity flow, unless otherwise specified. The MSFWS is composed of a pretreatment chamber, a biofiltration chamber and a discharge chamber. The pretreatment device houses cartridge media filters, which consist of filter media housed in a perforated enclosure. The untreated runoff flows into the system via subsurface piping and or surface inlet. Water entering the system is forced through the filter cartridge enclosures by gravity flow. Then the flow contacts the filter media. The flow through the media is horizontal toward the center of each individual media filter. In the center of the media shall be a round slotted PVC pipe of no greater than 1.5" in diameter. The slotted PVC pipe shall extend downward into the water transfer cavity of the cartridge. The slotted PVC pipe shall be threaded on the bottom to connect to the water transfer cavity. After pollutants have been removed by the filter media the water discharges the pretreatment chamber and flows into the water transfer system and is conveyed to the biofiltration chamber. Once runoff has been filtered by the biofiltration chamber it is collected by the vertical underdrain and conveyed to a discharge chamber equipped with a flow control orifice plate. Finally the treated flow exits the system.

03.01.02

Pollutants - The MSFWS will remove and retain debris, sediments, TSS, dissolved and particulate metals and nutrients including nitrogen and phosphorus species, bacteria, BOD, oxygen demanding substances, organic compounds and hydrocarbons entering the filter during frequent storm events and continuous dry weather flows.

03.01.03

Treatment Flow Rate and Bypass - The MSFWS operates in-line. The MSFWS will treat 100% of the required water quality treatment flow based on a minimum filtration capacities listed in section 03.02.00. The size of the system must match those provided on the drawing to ensure proper performance and hydraulic residence time.

03.02.00 Minimum Treatment Capabilities

System must be capable of treating flows to the specified treatment flow rate on the drawings. The flow rate shall be controlled by an orifice.

PART 4 - EXECUTION

04.01.00 General

The installation of the MSFWS shall conform to all applicable national, state, state highway, municipal and local specifications.

04.02.00 Installation

The Contractor shall furnish all labor, equipment, materials and incidentals required to install the (MSFWS) device(s) and appurtenances in accordance with the drawings and these specifications.

04.02.01

Grading and Excavation site shall be properly surveyed by a registered professional surveyor, and clearly marked with excavation limits and elevations. After site is marked it is the responsibility of the contractor to contact local utility



A Forterra Company

companies and/or DigAlert to check for underground utilities. All grading permits shall be approved by governing agencies before commencement of grading and excavation. Soil conditions shall be tested in accordance with the governing agencies requirements. All earth removed shall be transported, disposed, stored, and handled per governing agencies standards. It is the responsibility of the contractor to install and maintain proper erosion control measures during grading and excavation operations.

- 04.02.02 Compaction – All soil shall be compacted per registered professional soils engineer's recommendations prior to installation of MSFWS components.
- 04.02.03 Backfill shall be placed according to a registered professional soils engineer's recommendations, and with a minimum of 6" of gravel under all concrete structures.
- 04.02.04 Concrete Structures – After backfill has been inspected by the governing agency and approved the concrete structures shall be lifted and placed in proper position per plans.
- 04.02.05 Subsurface Flow Wetland Media shall be carefully loaded into area so not to damage the Wetland Liner or Water Transfer Systems. The entire wetland area shall be filled to a level 9 inches below finished surface.
- 04.02.06 Planting layer shall be installed per manufacturer's drawings and consist of a minimum 3" grow enhancement media that ensures greater than 95% plant survival rate; and 6" of wetland media. Planting shall consist of native plants recommended by manufacturer and/or landscape architect. Planting shall be drip irrigated for at least the first 3 months to insure long term plant growth. No chemical herbicides, pesticides, or fertilizers shall be used in the planting or care and maintenance of the planted area.

04.03.00 Shipping, Storage and Handling

- 04.03.01 Shipping – MSFWS shall be shipped to the contractor's address or job site, and is the responsibility of the contractor to offload the unit(s) and place in the exact site of installation.
- 04.03.02 Storage and Handling– The contractor shall exercise care in the storage and handling of the MSFWS and all components prior to and during installation. Any repair or replacement costs associated with events occurring after delivery is accepted and unloading has commenced shall be born by the contractor. The MSFWS(s) and all components shall always be stored indoors and transported inside the original shipping container until the unit(s) are ready to be installed. The MSFWS shall always be handled with care and lifted according to OSHA and NIOSA lifting recommendations and/or contractor's workplace safety professional recommendations.

04.04.00 Maintenance and Inspection

- 04.04.01 **Inspection** – After installation, the contractor shall demonstrate that the MSFWS has been properly installed at the correct location(s), elevations, and with appropriate components. All components associated with the MSFWS and its installation shall be subject to inspection by the engineer at the place of installation. In addition, the contractor shall demonstrate that the MSFWS has been installed per the manufacturer's specifications and recommendations. All components shall be inspected by a qualified person once a year and results of inspection shall be kept in an inspection log.
- 04.04.02 **Maintenance** – The manufacturer recommends cleaning and debris removal maintenance of once a year and replacement of the Cartridge Filters as needed. The maintenance shall be performed by someone qualified. A Maintenance Manual is available upon request from the manufacturer. The manual has detailed information regarding the maintenance of the MSFWS. A Maintenance/Inspection record shall be kept by the maintenance operator. The record shall include any maintenance activities performed, amount and description of debris collected, and the condition of the filter.
- 04.04.03 **Material Disposal** - All debris, trash, organics, and sediments captured by the MSFWS shall be transported and disposed of at an approved facility for disposal in accordance with local and state requirements. Please refer to state and local regulations for the proper disposal of toxic and non-toxic material.

PART 5 – QUALITY ASSURANCE

05.01.00 Warranty

The Manufacturer shall guarantee the MSFWS against all manufacturing defects in materials and workmanship for a period of (5) years from the date of delivery to the _____. The manufacturer shall be notified of repair or replacement issues in writing within the warranty period. The MSFWS is limited to recommended application for which it was designed.

05.02.00 Performance Certification

The MSFWS manufacturer shall submit to the Engineer of Record a "Manufacturer's Performance Certificate" certifying the MSFWS is capable of achieving the specified removal efficiency for suspended solids, phosphorous and dissolved metals.

APPENDIX C



Installation Guidelines for Modular Wetland System

Delivery & Unloading/Lifting

1. Modular Wetland Systems, Inc. shall deliver the unit(s) to the site in coordination with the Contractor.
2. The Contractor will require spreader bars and chains/cables to safely and securely lift the main structure, risers a set of suitable lifting hooks, knuckles, shackles and eye bolts.
3. The main structure and lid can be lifted together or separately.

Please see Modular Wetland Weights and Lifting Details. Contact Modular Wetlands for additional lifting details.

Inspection

1. Inspection of the Modular Wetland unit and all parts contained in or shipped outside of the unit shall be inspected at time of delivery by the site Engineer/Inspector and the Contractor. Any non-conformance to approved drawings or damage to any part of the system shall be documented on the Modular Wetland shipping ticket. Damage to the unit during and after unloading shall be corrected at the expense of the Contractor. Any necessary repairs to the Modular Wetland unit shall be made to the acceptance of the Engineer/Inspector.

Site Preparation

1. The Contractor is responsible for providing adequate and complete site/inlet protection when the Modular Wetland unit is installed prior to final site stabilization (full landscaping, grass cover, final paving, and street sweeping completed).
2. The Contractor shall adhere to all jurisdictional and/or OSHA safety rules in providing temporary shoring of the excavation.
3. The Contractor or Owner is responsible for appropriately barricading the Modular Wetland unit from traffic (in accordance with local codes).

Installation Guidelines for Modular Wetland System



Installation

1. Each unit shall be constructed at the locations and elevations according to the sizes shown on the approved drawings. Any modifications to the elevation or location shall be at the direction of and approved by the Engineer.
2. The unit shall be placed on the compacted sub-grade with a minimum 6-inch gravel base matching the final grade of the curb line in the area of the unit. The unit is to be placed such that the unit and top slab match the grade of the curb in the area of the unit. Compact undisturbed sub-grade materials to 95% of maximum density at +1% to 2% of the optimum moisture. Unsuitable material below sub-grade shall be replaced to site engineer's approval. Please see Modular Wetlands Weights and Lifting Details. Contact Modular Wetlands for guidance where slope exceeds 0.5%.
3. Once the unit is set, the internal wooden forms and protective silt fabric cover must be left intact (if WetlandMedia pre-installed). The top lid(s) should be sealed onto the box section before backfilling, using a non-shrink grout, butyl rubber or similar waterproof seal. The boards on the top of the lid and boards sealed in the unit's throat must NOT be removed. The Supplier will remove these sections at the time of activation.
4. Outlet connections shall be aligned and sealed to meet the approved drawings with modifications necessary to meet site conditions and local regulations. The correct outlet will be marked on the Modular Wetland unit.
5. Backfilling should be performed in a careful manner, bringing the appropriate fill material up in 6-inch lifts on all sides. Precast sections shall be set in a manner that will result in a watertight joint. In all instances, installation of the Modular Wetland unit shall conform to ASTM specification C891 "Standard Practice for Installation of Underground Precast Utility Structures" unless specified otherwise in contract documents.
6. It is the responsibility of the Contractor to provide curb and gutter and transition to the Modular Wetland unit for proper stormwater flow into the system through the throat, pipe or grate opening. A standard drawing of the throat and gutter detail is available in the following section; however the plans and contract documents supersede all standard drawings. Several variations of the standard design are available. Effective bypass for the Modular Wetland System is essential for correct operation (i.e. bypass to an overflow at lower elevation).

Installation Procedure

The contractor **MUST** provide all rigging and lifting apparatus, such as all cables, chains or straps and a set of lifting hooks, shackles, knuckles and eye bolts.

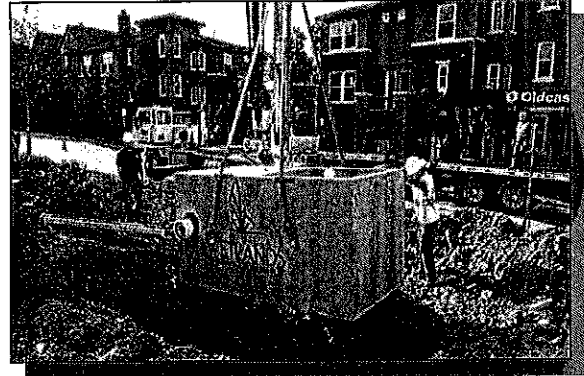

It is the contractor's responsibility to provide suitable lifting equipment to off-load the Modular Wetland unit.

Modular Wetland units are designed to be off-loaded using the contractor's spreader bar.

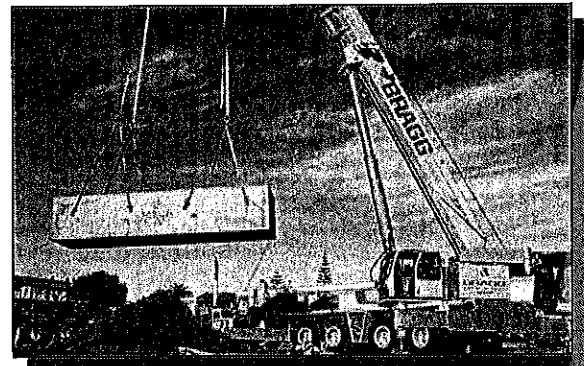

1. Apply Butyl Tape Seal

Apply butyl tape seal along the top of the box section. Butyl tape seal is provided with every unit.

Modular Wetland installed protective throat board and installed silt fabric must be left in place to protect the unit from construction sediment.

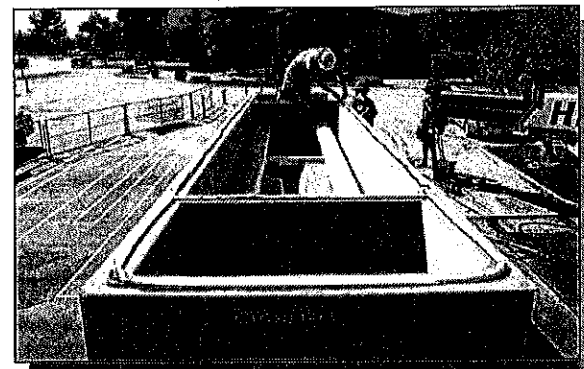

2. Unload and Set Box

Unload the Modular Wetland unit
the prepared hole with appropriate sub-grade.*

* Compacted sub-grade with a minimum
of six inches of gravel base which must match
the final grade of curb line the area of the unit.

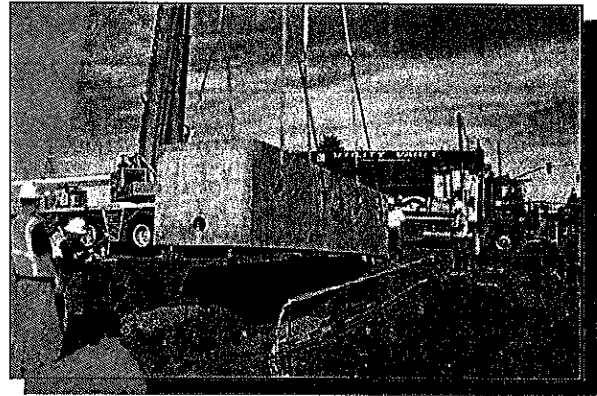

3. Set Top On Box

Set the top slab on the box.

The Contractor is responsible for providing
adequate and complete site/inlet protection
when the Modular Wetland is installed prior
to final site stabilization (full landscaping,
grass cover, final paving, and street sweeping
completed).

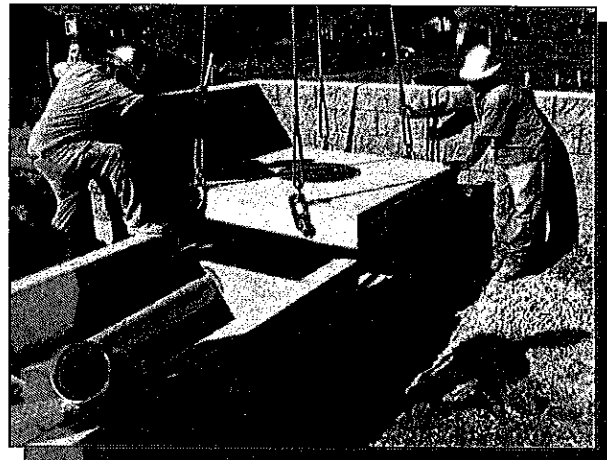

4. Connect Outfall Pipe

The correct outlet will be marked on the
Modular Wetland.

Invert of outlet pipe **MUST** be even
with the floor of the system.

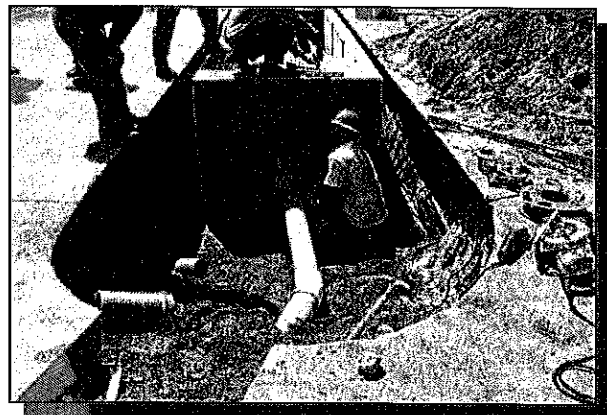



5. Install Curb & Gutter

It is the responsibility of the Contractor to provide curb and gutter and transition to the Modular Wetland for proper flow into the system through a 5"- 7" throat opening. A standard drawing of the throat and gutter detail in the following section. **CONTRACTOR RESPONSIBLE FOR GROUTING IN ANY VISIBLE LIFTING POINTS.**

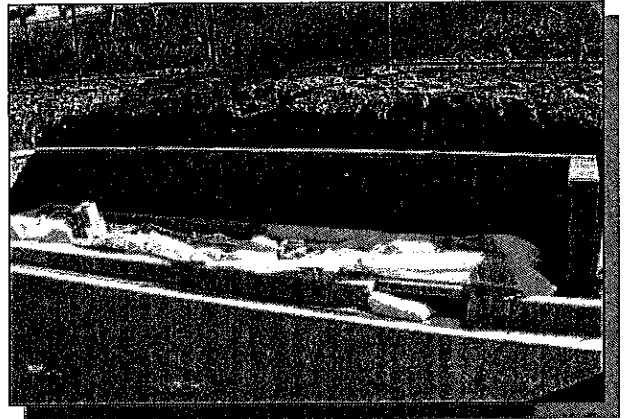

6. Activation

Activation is performed **ONLY** by Modular Wetland personnel.

Activation can occur once the project site is fully stabilized (full landscaping, grass cover, final paving and street sweeping completed) and there is a 5" - 7" throat opening.

Call 760-433-7640 to schedule your activation.

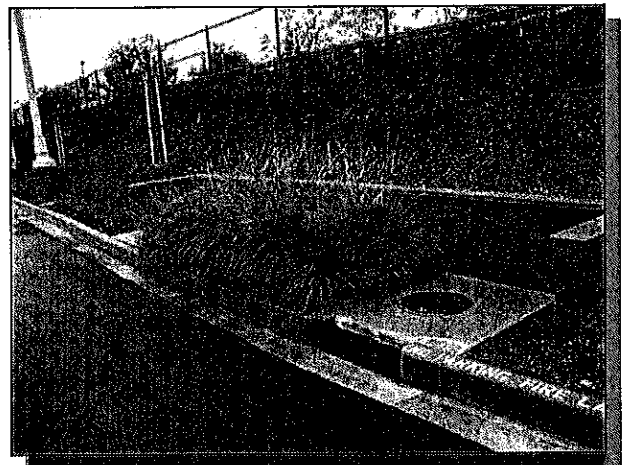

NOTE: WetlandMedia Installation

For Larger models (MWS-L-4-13 and above) the system will be delivered without WetlandMedia pre-installed to minimize pick weight and prevent contamination of the media during construction. For these models the WetlandMedia will be delivered in bulk or in super sacks. It will be responsibility of the contractor to fill the system with the WetlandMedia during the installation process. Installation of the WetlandMedia can be done after the unit is fully installed to avoid contamination. See following pages for details.

WetlandMedia Install (if applicable)

1. Fill WetlandMedia

Position super sack of WetlandMedia over wetland chamber. Bottom of sack should not be more than 2' above top of system. Open sack and fill evenly*.

* One to several hundred cubic yards of WetlandMedia will be required based upon the model number and size of the system. For large scale jobs WetlandMedia will be delivered in bulk and will require a bobcat or similar to fill the system. All equipment is the responsibility of the contractor.

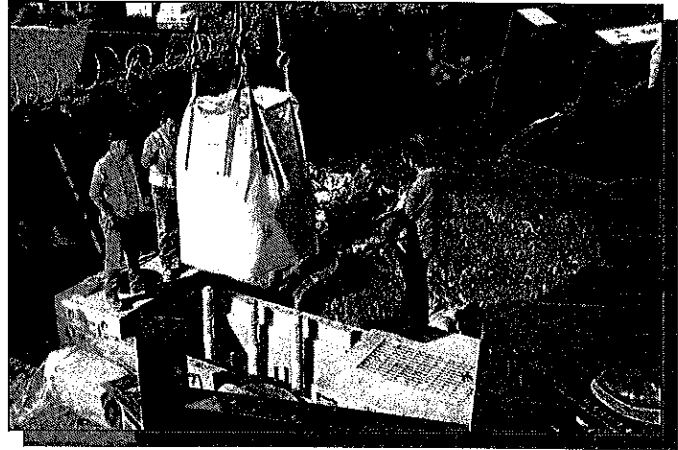

2. Install Plant Propagation Layer

Fill WetlandMedia up to 9" below the top of the wetland chamber. Level out the WetlandMedia as shown. Ensure that the level does not vary more than one inch or plant growth will be affected.

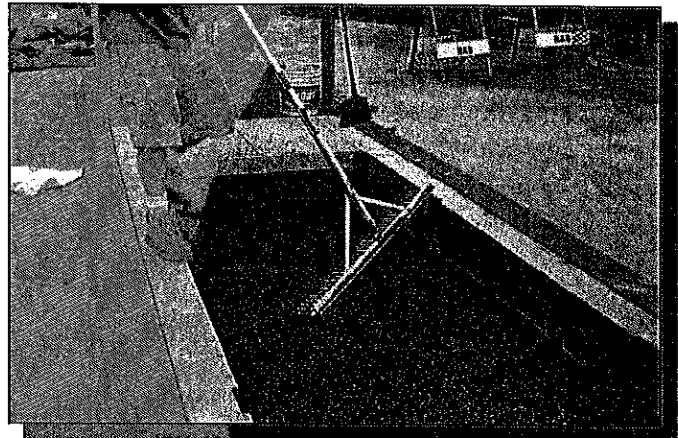

3. Install Plant Propagation Layer

Utilize plant propagation blocks provided by the manufacturer. Each block is approximately 40" by 6" by 3" thick. Blocks shall be placed side by side and end to end and cover the entire length and width of the wetland chamber unless specified.



4. Finish Filling WetlandMedia

After plant propagation blocks are installed repeat step 1 and fill the system to the top of the wetland chamber as shown. WetlandMedia must be filled within 2" of the top of the unit.



5. Planting

After system is filled with WetlandMedia planting of vegetation can begin. Utilizing 1 gallon plants dig down until The plant propagation blocks are reached. Remove plant and it's root ball from the container. Set the bottom of the root ball on the tops of the blocks. Fill hole back in with WetlandMedia. After planting a thorough watering of the plants is necessary. The plant propagation blocks must be saturated to provide a water source for the plants during the establishment phase. It is recommended that hand watering is done three times a week for the first two months. Hand water can be supplemented with drip or spray irrigation after the second week. Please call the manufacturer for more details on plants, planting arrangement and irrigation options.

NOTE: planting is required on all units, including units delivered with WetlandMedia pre-installed.

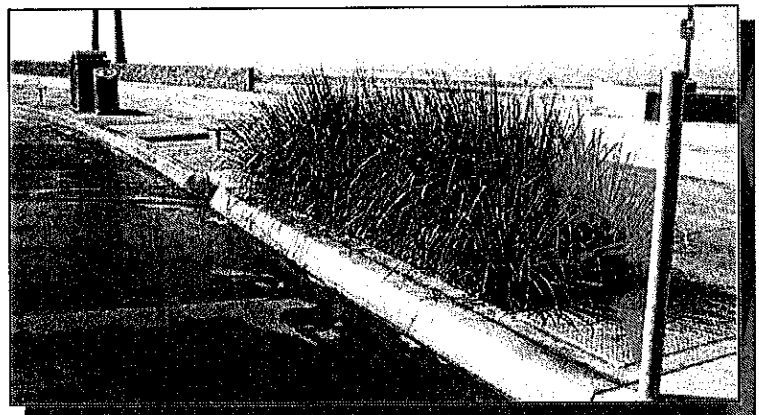
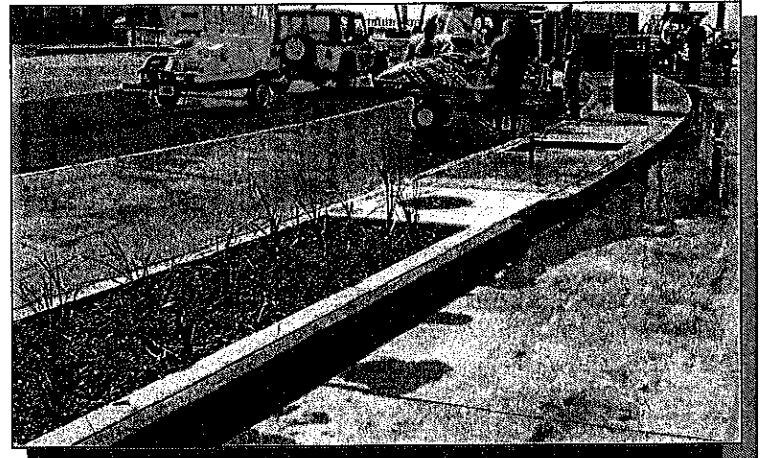



Curb and Gutter Details

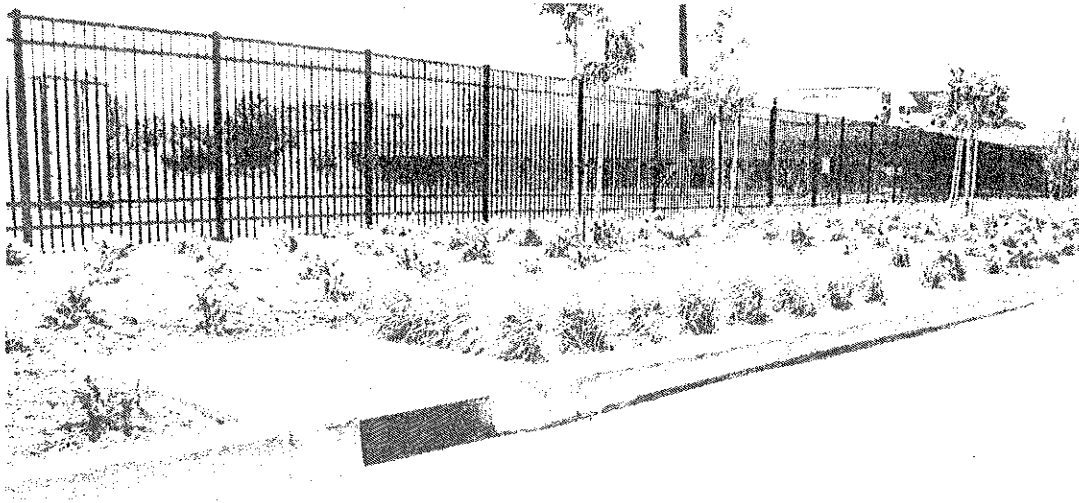

Modular Wetland System, Inc.

P. 760.433-7640

F. 760-433-3176

E. Info@modularwetlands.com

www.modularwetlands.com

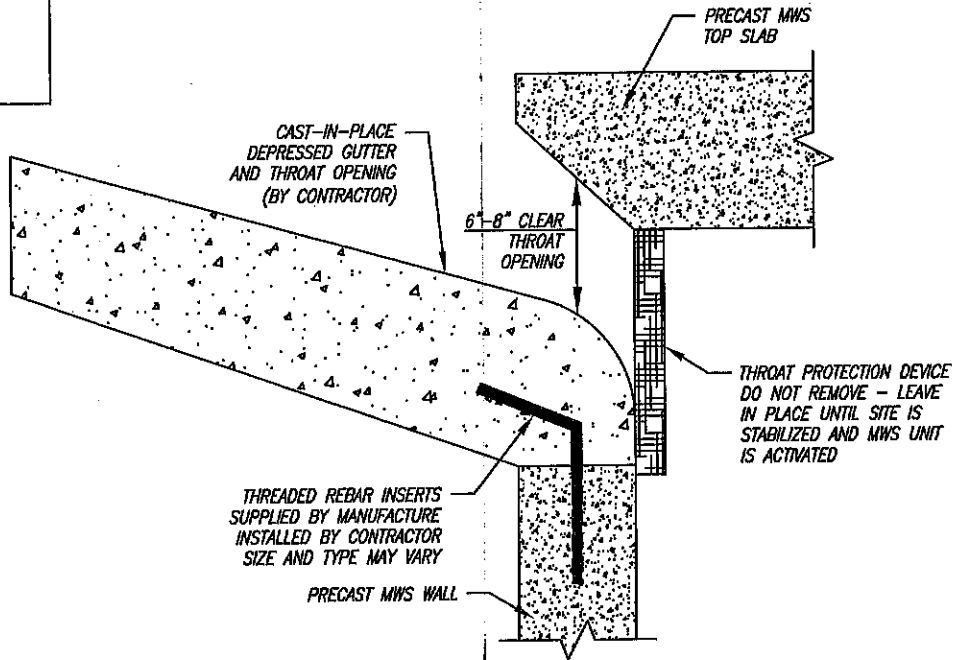

SECTION VIEW
STANDARD MODULAR WETLAND CURB OPENING

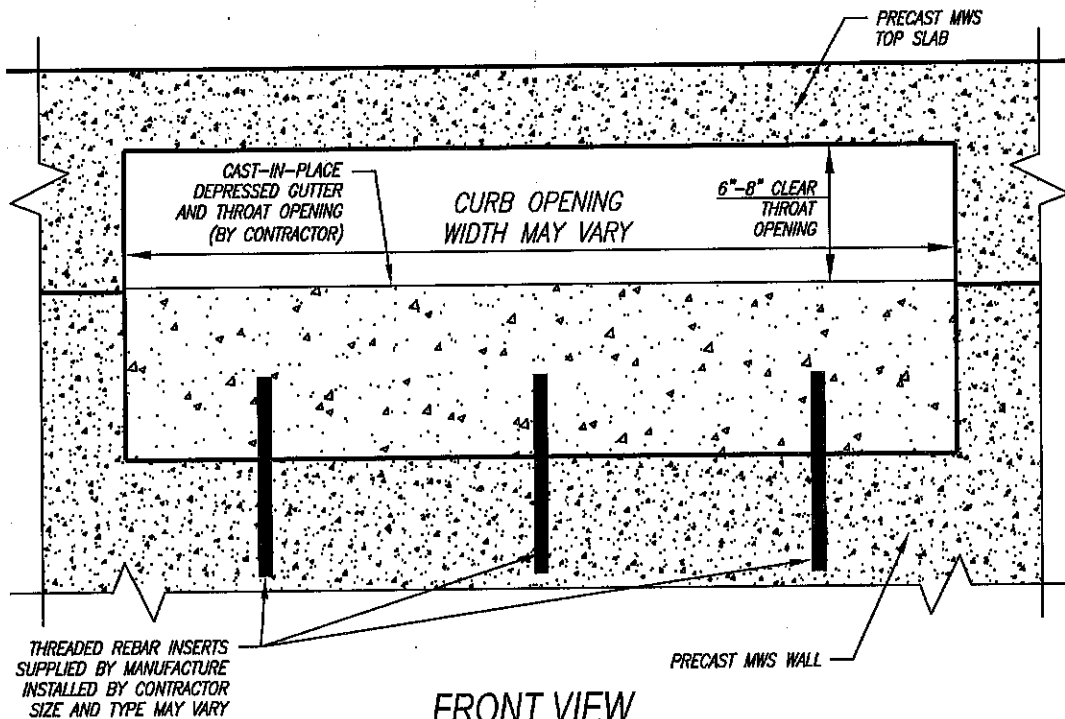

FRONT VIEW
STANDARD MODULAR WETLAND CURB OPENING

MODULAR WETLAND SYSTEMS INC.
P.O. BOX 869
OCEANSIDE, CA 92049
www.ModularWetlands.com

PROPRIETARY AND CONFIDENTIAL
THE INFORMATION CONTAINED IN THIS DRAWING IS THE SOLE PROPERTY OF MODULAR WETLAND SYSTEMS INC. ANY REPRODUCTION IN PART OR AS A WHOLE WITHOUT THE WRITTEN PERMISSION OF MODULAR WETLAND SYSTEMS INC. IS PROHIBITED.

	NAME	DATE
DRAWN	John	5/3/13
EDITED		

COMMENTS:

TITLE: MWS LINEAR 2.0 CURB INLET DETAILS		
SIZE	DWG. NO.	REV
SCALE	NTS	UNITS = INCHES
SHEET 1 OF 1		



Weights and Lifting Details

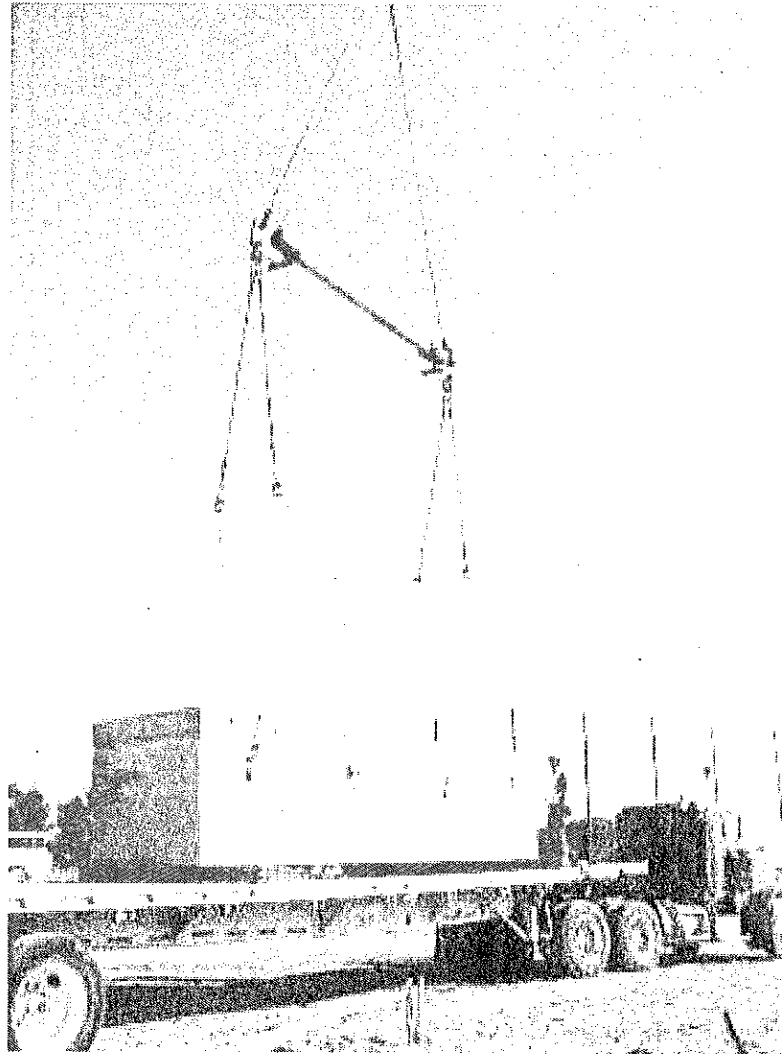

Modular Wetland System, Inc.

P. 760.433-7640

F. 760-433-3176

E. Info@modularwetlands.com

www.modularwetlands.com

MWS-L 2.0 Max Pick Weights

Model #	Size (O.D)	Size (I.D)	Unit Weight (lbs)	Media Weight (lbs)	Total Weight (lbs)
MWS-L-4-4	5' x 5'	4' x 4'	7500.0	1607.7	9107.7
MWS-L-4-6 MWS-L-4-6.5	5' x 7' 5 x 7.5'	4' x 6' 4' x 6.5'	11,000 11,500	1798.9	12,619.2 13,119.2
MWS-L-4-8	5' x 9'	8' x 4'	12500	3966	16466
MWS-L-4-13	5' x 14'	13' x 4'	21200	5895	27095
MWS-L-4-15	5' x 16'	15' x 4'	23700	8039	31739
MWS-L-4-17	5' x 18'	17' x 4'	26500	10182	36682
MWS-L-4-19	5' x 20'	19' x 4'	28300	12326	40626
MWS-L-4-21	5' x 22'	21' x 4'	30000	14470	44470
MWS-L-6-8	7' x 9'	6' x 8'	24000	6109	30109
MWS-L-8-8	9' x 9'	8' x 8'	32000	8253	40253
MWS-L-8-12	9' x 13'	8' x 12'	44000	12540	56540
MWS-L-8-16	9' x 17'	8' x 16'	47000	16828	63828

Max Pick Weight If Shipped
Without Media Installed

Max Pick Weight If Shipped
With Media Installed

Note: All weights listed hereon are standard max pick weights, actual pick weights may vary based upon state and local regulations and variation in concrete and rebar standards. For project specific pick weights contact the manufacturer prior to shipping of the unit(s). Is is the contractors responsibility to off-load the unit with an adequate size crane. Units are shipped with WetlandMEDIA in superbags and installed by contractor.

When Available see project contract terms, if lifting points are on the inside of the unit due to custom designs or installations requiring pions to be on the inside the media will be shipped in bags and the contractor will be responsible to install after the unit is installed. For example, units places against a wall.

For Questions or Comments Please Call 888-566-3938 or email: info@modularwetlands.com





Connection Details

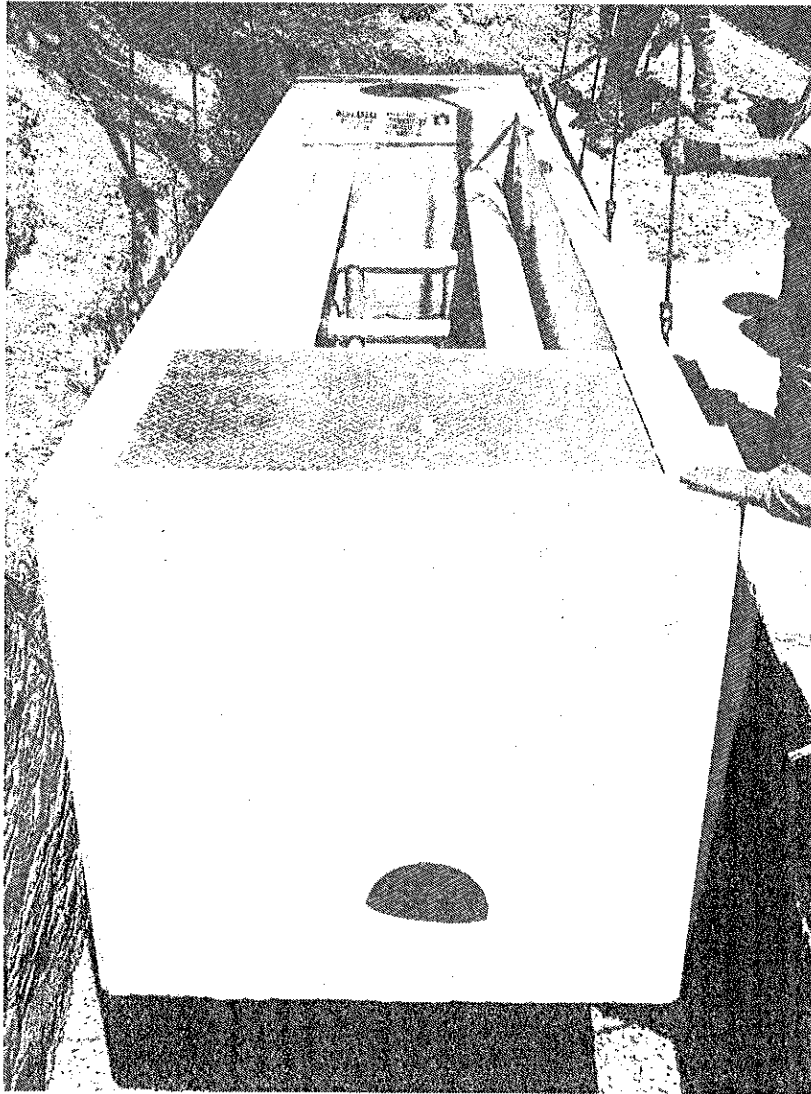

Modular Wetland System, Inc.

P. 760.433-7640

F. 760-433-3176

E: Info@modularwetlands.com

www.modularwetlands.com

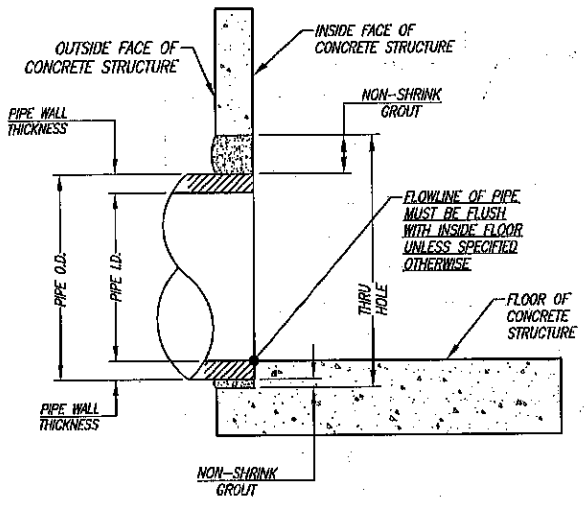

ELEVATION VIEW

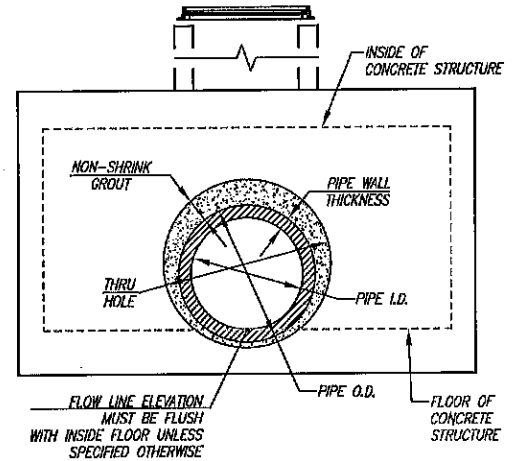

END VIEW

INSTALLATION NOTES

1. ALL CONNECTION PIPES SUPPLIED AND INSTALLED BY CONTRACTOR. MODULAR WETLAND UNIT WILL BE DELIVERED WITH A THRU HOLE AND ITS THE CONTRACTORS RESPONSIBILITY TO SUPPLY PIPE, AND ALL LABOR AND MATERIAL TO CONNECT PIPE AND SEAL UNIT WATER TIGHT INCLUDING BUT NOT LIMITED TO GROUT, CONCRETE LUG, REBAR, FLUG, ANCHORS, COUPLER, FITTINGS AND/OR ALL SUPPORT AND CONNECTING HARDWARE.
2. ALL CONNECTIONS ARE TO BE FLUSH WITH THE INSIDE SURFACE OF THE CONCRETE STRUCTURE. (CAN NOT INTRUDE BEYOND FLUSH) ALL PIPE FLOWLINES SHALL BE FLUSH WITH INSIDE FLOOR UNLESS SPECIFIED OTHERWISE.
3. ALL GROUT AND/OR CONCRETE SHALL BE NON-SHRINK AND MEET OR EXCEED LOCAL PIPE CONNECTION STANDARDS.
4. REFER TO AGENCY SPECIFICATIONS WHERE APPLICABLE.

THE PRODUCT DESCRIBED MAY BE PROTECTED BY ONE OR MORE OF THE FOLLOWING US PATENTS: 7,482,262; 7,470,362; 7,874,378; 8,303,818; RELATED FOREIGN PATENTS OR OTHER PATENTS PENDING

PROPRIETARY AND CONFIDENTIAL: THE INFORMATION CONTAINED IN THIS DRAWING IS THE SOLE PROPERTY OF MODULAR WETLANDS SYSTEMS. ANY REPRODUCTION IN PART OR AS A WHOLE WITHOUT THE WRITTEN PERMISSION OF MODULAR WETLANDS SYSTEMS IS PROHIBITED.



**PIPE CONNECTION
STANDARD DETAIL**

APPENDIX D



Inspection Guidelines for Modular Wetland System - Linear

Inspection Summary

- Inspect Pre-Treatment, Biofiltration and Discharge Chambers – average inspection interval is 6 to 12 months.
 - (15 minute average inspection time).
- NOTE: Pollutant loading varies greatly from site to site and no two sites are the same. Therefore, the first year requires inspection monthly during the wet season and every other month during the dry season in order to observe and record the amount of pollutant loading the system is receiving.

System Diagram

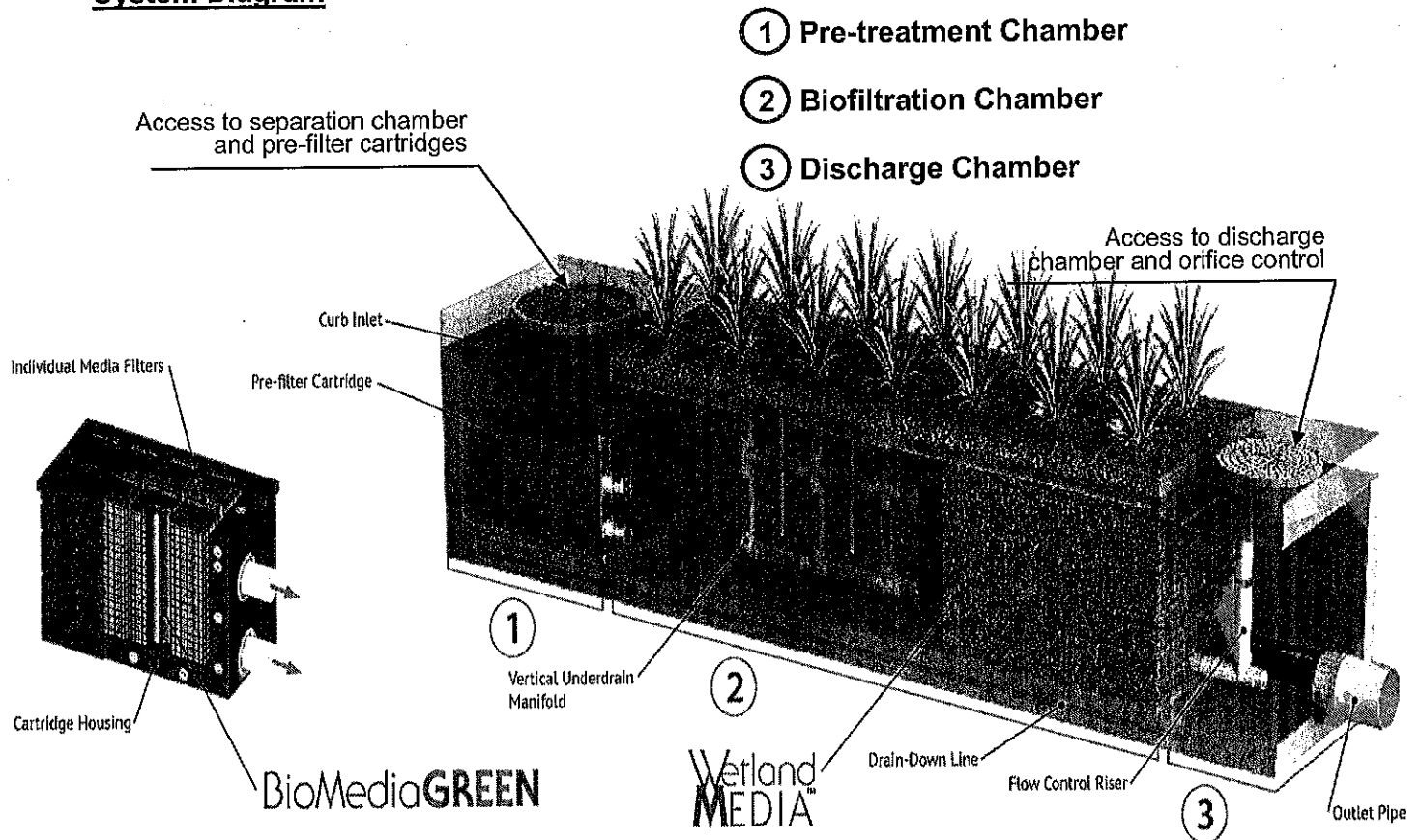



Inspection Overview

As with all stormwater BMPs inspection and maintenance on the MWS Linear is necessary.

Stormwater regulations require that all BMPs be inspected and maintained to ensure they are operating as designed to allow for effective pollutant removal and provide protection to receiving water bodies. It is recommended that inspections be performed multiple times during the first year to assess the site specific loading conditions. This is recommended because pollutant loading and pollutant characteristics can vary greatly from site to site. Variables such as nearby soil erosion or construction sites, winter sanding on roads, amount of daily traffic and land use can increase pollutant loading on the system. The first year of inspections can be used to set inspection and maintenance intervals for subsequent years to ensure appropriate maintenance is provided. Without appropriate maintenance a BMP will exceed its storage capacity which can negatively affect its continued performance in removing and retaining captured pollutants.

Inspection Equipment

Following is a list of equipment to allow for simple and effective inspection of the MWS Linear:

- Modular Wetland Inspection Form
- Flashlight
- Manhole hook or appropriate tools to remove access hatches and covers
- Appropriate traffic control signage and procedures
- Measuring pole and/or tape measure.
- Protective clothing and eye protection.
- 7/16" open or closed ended wrench.
- Large permanent black marker (initial inspections only – first year)
- Note: entering a confined space requires appropriate safety and certification. It is generally not required for routine inspections of the system.





Inspection Steps

The core to any successful stormwater BMP maintenance program is routine inspections. The inspection steps required on the MWS Linear are quick and easy. As mentioned above the first year should be seen as the maintenance interval establishment phase. During the first year more frequent inspections should occur in order to gather loading data and maintenance requirements for that specific site. This information can be used to establish a base for long term inspection and maintenance interval requirements.

The MWS Linear can be inspected through visual observation without entry into the system. All necessary pre-inspection steps must be carried out before inspection occurs, especially traffic control and other safety measures to protect the inspector and near-by pedestrians from any dangers associated with an open access hatch or manhole. Once these access covers have been safely opened the inspection process can proceed:

- Prepare the inspection form by writing in the necessary information including project name, location, date & time, unit number and other info (see inspection form).
- Observe the inside of the system through the access hatches. If minimal light is available and vision into the unit is impaired utilize a flashlight to see inside the system and all of its chambers.
- Look for any out of the ordinary obstructions in the inflow pipe, pre-treatment chamber, biofiltration chamber, discharge chamber or outflow pipe. Write down any observations on the inspection form.
- Through observation and/or digital photographs estimate the amount of trash, debris and sediment accumulated in the pre-treatment chamber. Utilizing a tape measure or measuring stick estimate the amount of trash, debris and sediment in this chamber. Record this depth on the inspection form.

- Through visual observation inspect the condition of the pre-filter cartridges. Look for excessive build-up of sediments on the cartridges, any build-up on the top of the cartridges, or clogging of the holes. Record this information on the inspection form. The pre-filter cartridges can further be inspected by removing the cartridge tops and assessing the color of the BioMediaGREEN filter cubes (requires entry into pre-treatment chamber – see notes above regarding confined space entry). Record the color of the material. New material is a light green in color. As the media becomes clogged it will turn darker in color, eventually becoming dark brown or black. Using the below color indicator record the percentage of media exhausted.

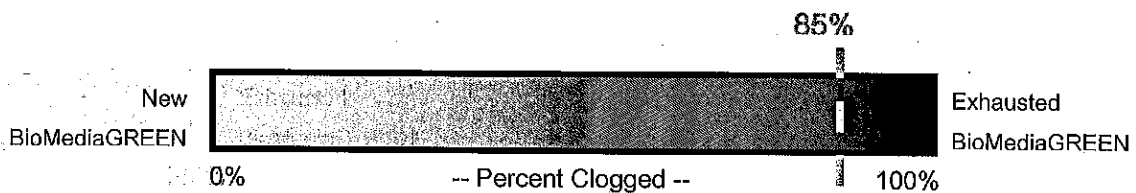

- The biofiltration chamber is generally maintenance free due to the system's advanced pre-treatment chamber. For units which have open planters with vegetation it is recommended that the vegetation be inspected. Look for any plants that are dead or showing signs of disease or other negative stressors. Record the general health of the plants on the inspection and indicate through visual observation or digital photographs if trimming of the vegetation is needed.
- The discharge chamber houses the orifice control structure, drain down filter and is connected to the outflow pipe. It is important to check to ensure the orifice is in proper operating conditions and free of any obstructions. It is also important to assess the condition of the drain down filter media which utilizes a block form of the BioMediaGREEN. Assess in the same manner as the cubes in the Pre-Filter Cartridge as mentioned above. Generally, the discharge chamber will be clean and free of debris. Inspect the water marks on the side walls. If possible, inspect the discharge chamber during a rain event to assess the amount of flow leaving the system while it is at 100% capacity (pre-treatment chamber water level at peak HGL). The water level of the flowing water should be compared to the watermark level on the side walls which is an indicator of the highest discharge rate the system achieved when initially installed. Record on the form if there is any difference in level from watermark in inches.

- NOTE: During the first few storms the water level in the outflow chamber should be observed and a 6" long horizontal watermark line drawn (using a large permanent marker) at the water level in the discharge chamber while the system is operating at 100% capacity. The diagram below illustrates where a line should be drawn. This line is a reference point for future inspections of the system:

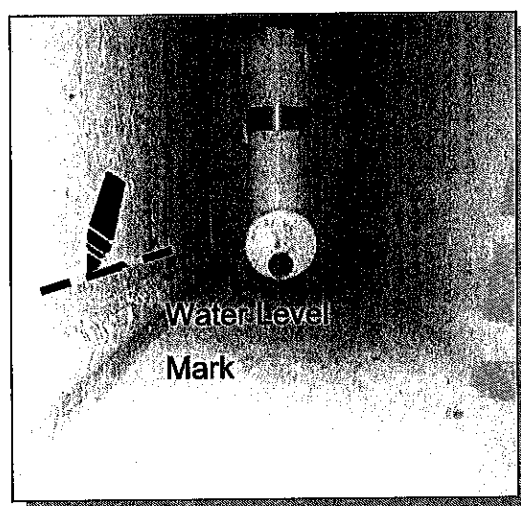
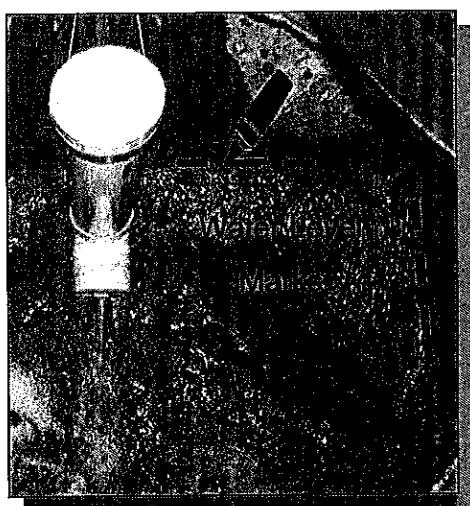

Using a permanent marker draw a 6 inch long horizontal line, as shown, at the higher water level in the MWS Linear discharge chamber.

- Water level in the discharge chamber is a function of flow rate and pipe size. Observation of water level during the first few months of operation can be used as a benchmark level for future inspections. The initial mark and all future observations shall be made when system is at 100% capacity (water level at maximum level in pre-treatment chamber). If future water levels are below this mark when system is at 100% capacity this is an indicator that maintenance to the pre-filter cartridges may be needed.
- Finalize inspection report for analysis by the maintenance manager to determine if maintenance is required.

Maintenance Indicators

Based upon observations made during inspection, maintenance of the system may be required based on the following indicators:

- Missing or damaged internal components or cartridges.
- Obstructions in the system or its inlet or outlet.
- Excessive accumulation of floatables in the pre-treatment chamber in which the length and width of the chamber is fully impacted more than 18".



- Excessive accumulation of sediment in the pre-treatment chamber of more than 6" in depth.

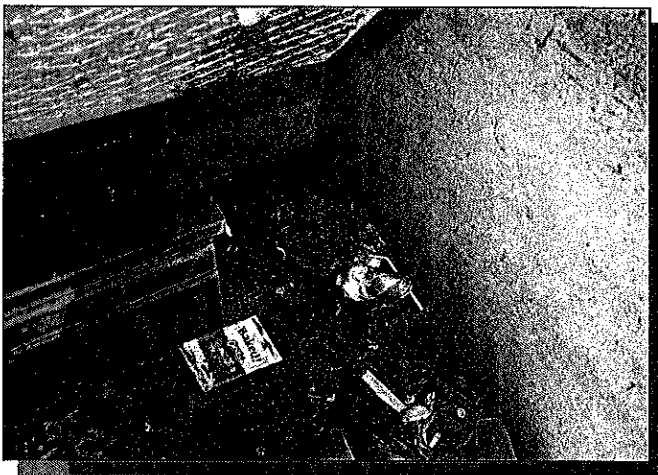

- Excessive accumulation of sediment on the BioMediaGREEN media housed within the pre-filter cartridges. The following chart shows photos of the condition of the BioMediaGREEN contained within the pre-filter cartridges. When media is more than 85% clogged replacement is required.

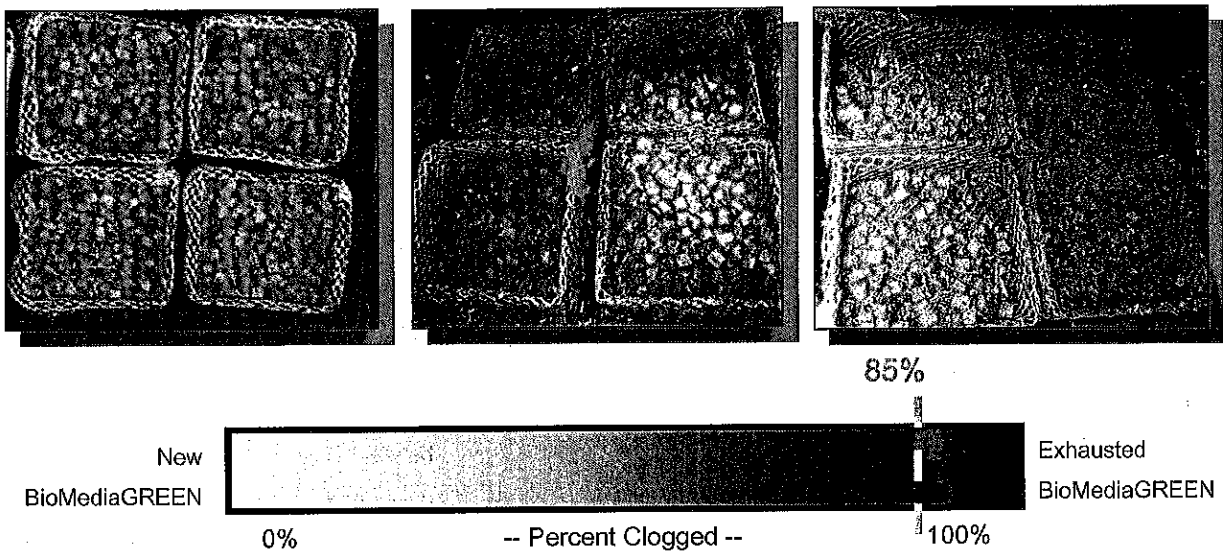

- Excessive accumulation of sediment on the BioMediaGREEN media housed within the drain down filter. The following photos show of the condition of the BioMediaGREEN contained within the drain down filter. When media is more than 85% clogged replacement is required.

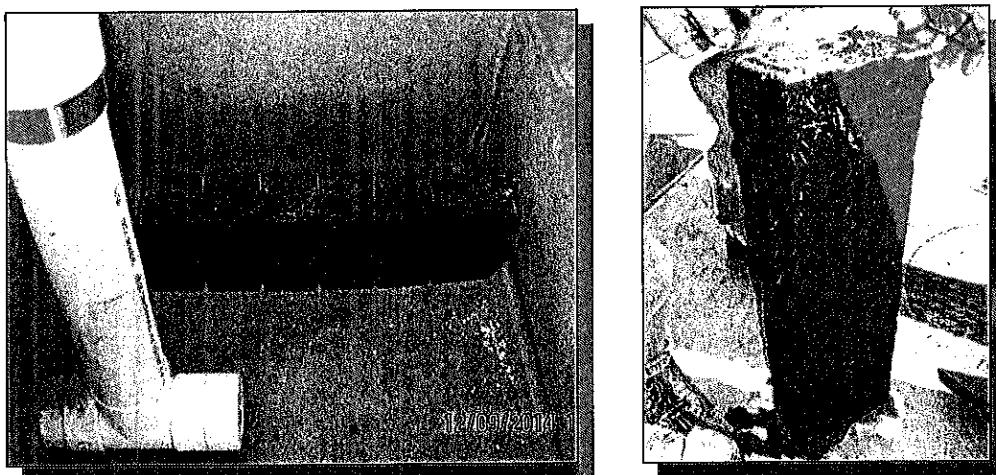

- Overgrown vegetation.

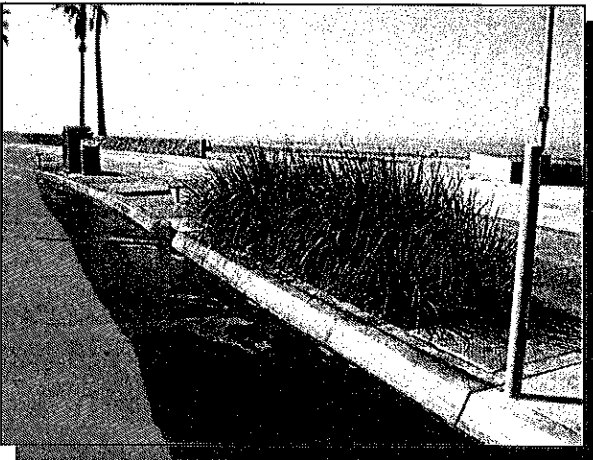

- Water level in discharge chamber during 100% operating capacity (pre-treatment chamber water level at max height) is lower than the watermark by 20%.



Inspection Notes

1. Following maintenance and/or inspection, it is recommended the maintenance operator prepare a maintenance/inspection record. The record should include any maintenance activities performed, amount and description of debris collected, and condition of the system and its various filter mechanisms.
2. The owner should keep maintenance/inspection record(s) for a minimum of five years from the date of maintenance. These records should be made available to the governing municipality for inspection upon request at any time.
3. Transport all debris, trash, organics and sediments to approved facility for disposal in accordance with local and state requirements.
4. Entry into chambers may require confined space training based on state and local regulations.
5. No fertilizer shall be used in the Biofiltration Chamber.
6. Irrigation should be provided as recommended by manufacturer and/or landscape architect. Amount of irrigation required is dependent on plant species. Some plants may not require irrigation after initial establishment.

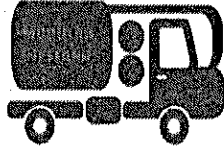

Maintenance Guidelines for Modular Wetland System - Linear

Maintenance Summary

- Remove Sediment from Pre-Treatment Chamber – average maintenance interval is 12 to 24 months.
 - (10 minute average service time).
- Replace Pre-Filter Cartridge Media – average maintenance interval 12 to 24 months.
 - (10-15 minute per cartridge average service time).
- Trim Vegetation – average maintenance interval is 6 to 12 months.
 - (Service time varies).

System Diagram

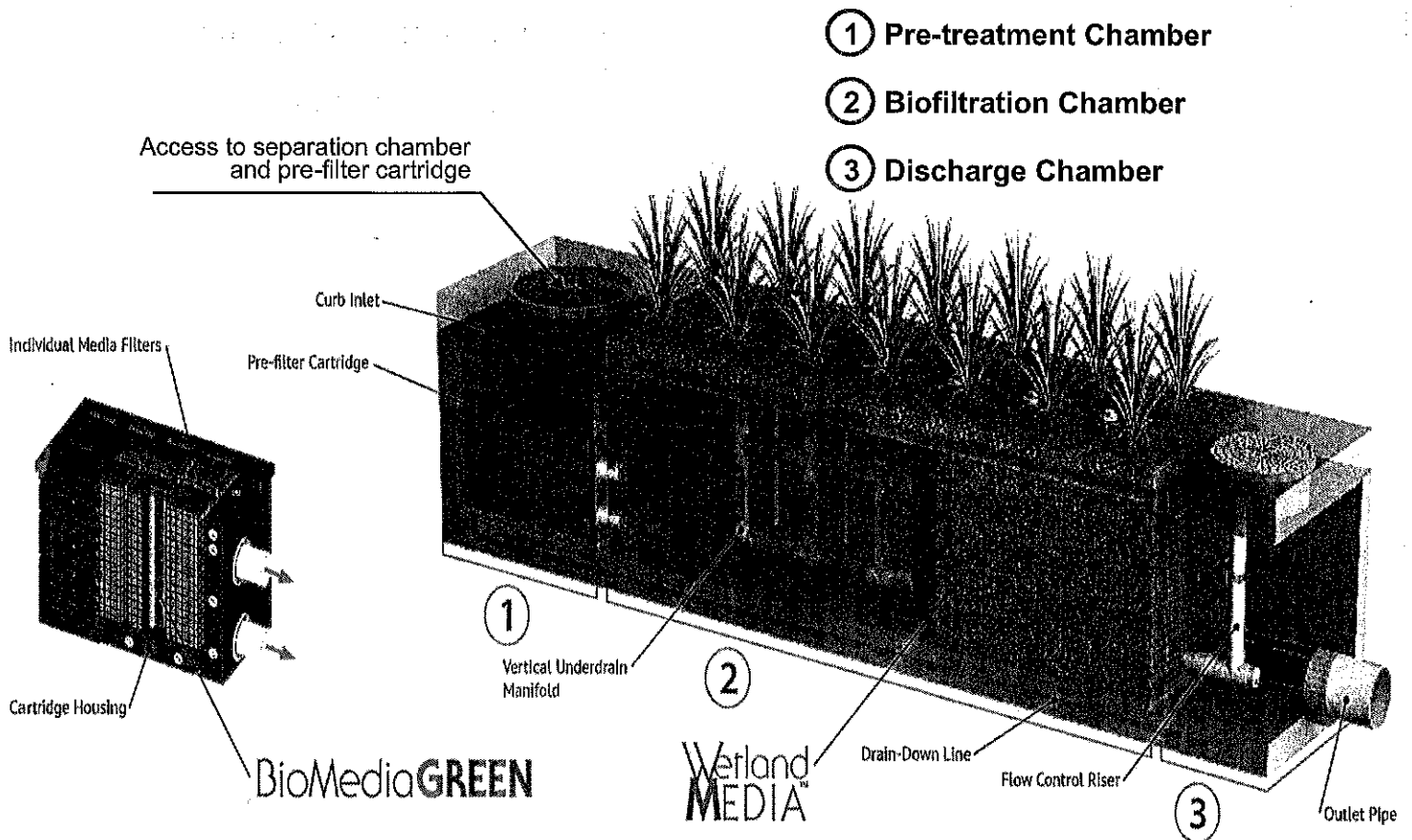

www.modularwetlands.com



Maintenance Overview

The time has come to maintain your Modular Wetland System Linear (MWS Linear). To ensure successful and efficient maintenance on the system we recommend the following. The MWS Linear can be maintained by removing the access hatches over the systems various chambers. All necessary pre-maintenance steps must be carried out before maintenance occurs, especially traffic control and other safety measures to protect the inspector and near-by pedestrians from any dangers associated with an open access hatch or manhole. Once traffic control has been set up per local and state regulations and access covers have been safely opened the maintenance process can begin. It should be noted that some maintenance activities require confined space entry. All confined space requirements must be strictly followed before entry into the system. In addition the following is recommended:

- Prepare the maintenance form by writing in the necessary information including project name, location, date & time, unit number and other info (see maintenance form).
- Set up all appropriate safety and cleaning equipment.
- Ensure traffic control is set up and properly positioned.
- Prepare a pre-checks (OSHA, safety, confined space entry) are performed.

Maintenance Equipment

Following is a list of equipment required for maintenance of the MWS Linear:

- Modular Wetland Maintenance Form
- Manhole hook or appropriate tools to access hatches and covers
- Protective clothing, flashlight and eye protection.
- 7/16" open or closed ended wrench.
- Vacuum assisted truck with pressure washer.
- Replacement BioMediaGREEN for Pre-Filter Cartridges if required (order from manufacturer).



Maintenance Steps

1. Pre-treatment Chamber (bottom of chamber)

A. Remove access hatch or manhole cover over pre-treatment chamber and position vacuum truck accordingly.

B. With a pressure washer spray down pollutants accumulated on walls and pre-filter cartridges.

C. Vacuum out Pre-Treatment Chamber and remove all accumulated pollutants including trash, debris and sediments. Be sure to vacuum the floor until pervious pavers are visible and clean.

D. If Pre-Filter Cartridges require media replacement move onto step 2. If not, replace access hatch or manhole cover.

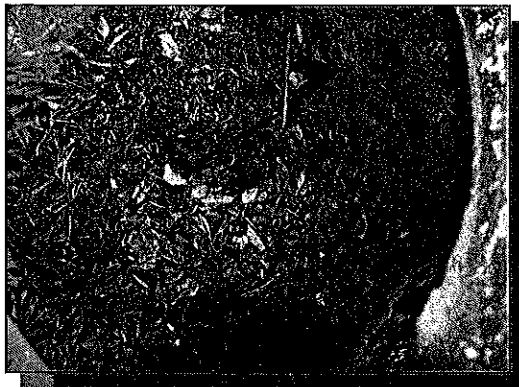

Removal of access hatch to gain access below.



Insertion of vacuum hose into separation chamber.



Removal of trash, sediment and debris.

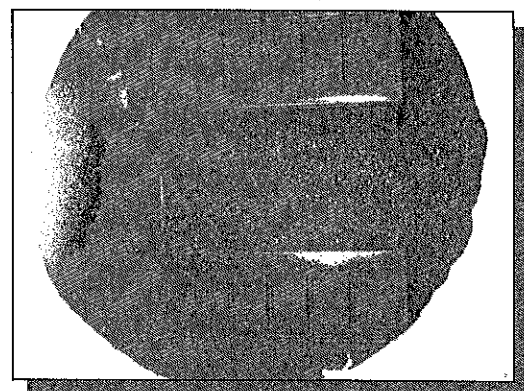

Fully cleaned separation chamber.

2. Pre-Filter Cartridges (attached to wall of pre-treatment chamber)

- A. After finishing step 1 enter pre-treatment chamber.
- B. Unscrew the two bolts holding the lid on each cartridge filter and remove lid.

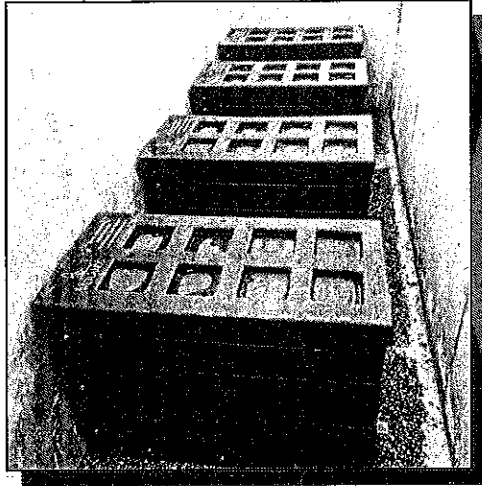

Pre-filter cartridges with tops on.

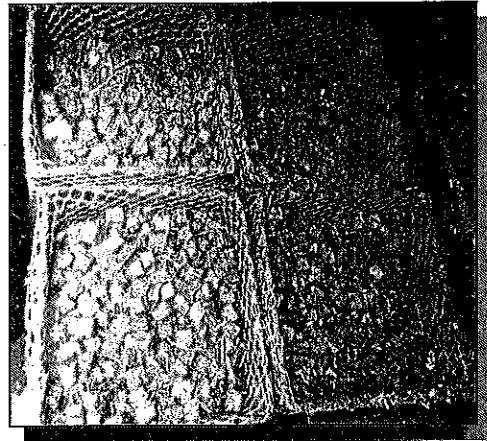

Inside cartridges showing media filters ready for replacement.

- C. Place the vacuum hose over each individual media filter to suck out filter media.

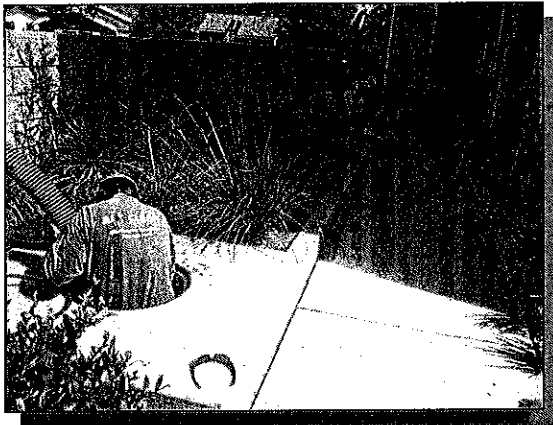

Vacuuming out of media filters.

- D. Once filter media has been sucked use a pressure washer to spray down inside of the cartridge and it's containing media cages. Remove cleaned media cages and place to the side. Once removed the vacuum hose can be inserted into the cartridge to vacuum out any remaining material near the bottom of the cartridge.

- E. Reinstall media cages and fill with new media from manufacturer or outside supplier. Manufacturer will provide specification of media and sources to purchase. Utilize the manufacture provided refilling tray and place on top of cartridge. Fill tray with new bulk media and shake down into place. Using your hands slightly compact media into each filter cage. Once cages are full removed refilling tray and replace cartridge top ensuring bolts are properly tightened.

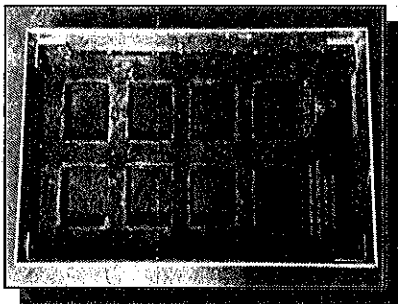

Refilling tray for media replacement.

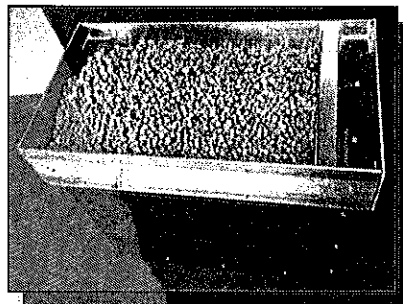

Refilling tray on cartridge with bulk media.

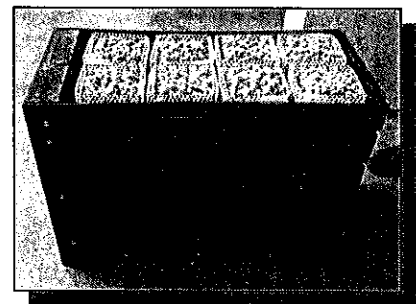

- F. Exit pre-treatment chamber. Replace access hatch or manhole cover.

3. Biofiltration Chamber (middle vegetated chamber)

- A. In general, the biofiltration chamber is maintenance free with the exception of maintaining the vegetation. Using standard gardening tools properly trim back the vegetation to healthy levels. The MWS Linear utilizes vegetation similar to surrounding landscape areas therefore trim vegetation to match surrounding vegetation. If any plants have died replace plants with new ones:

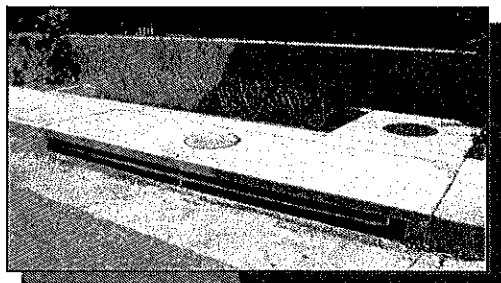

4. Discharge Chamber (contains drain down cartridge & connected to pipe)

- A. Remove access hatch or manhole cover over discharge chamber.
- B. Enter chamber to gain access to the drain down filter. Unlock the locking mechanism and lift up drain down filter housing to remove used BioMediaGREEN filter block as shown below:

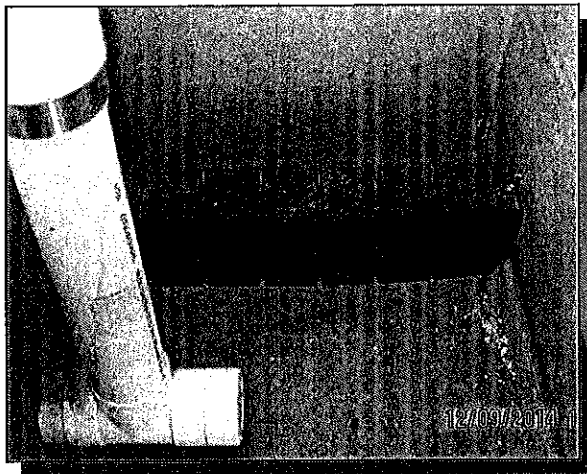

- C. Insert new BioMediaGREEN filter block and lock drain down filter housing back in place. Replace access hatch or manhole cover over discharge chamber.



Inspection Notes

1. Following maintenance and/or inspection, it is recommended the maintenance operator prepare a maintenance/inspection record. The record should include any maintenance activities performed, amount and description of debris collected, and condition of the system and its various filter mechanisms.
2. The owner should keep maintenance/inspection record(s) for a minimum of five years from the date of maintenance. These records should be made available to the governing municipality for inspection upon request at any time.
3. Transport all debris, trash, organics and sediments to approved facility for disposal in accordance with local and state requirements.
4. Entry into chambers may require confined space training based on state and local regulations.
5. No fertilizer shall be used in the Biofiltration Chamber.
6. Irrigation should be provided as recommended by manufacturer and/or landscape architect. Amount of irrigation required is dependent on plant species. Some plants may not require irrigation after initial establishment.



Inspection Form

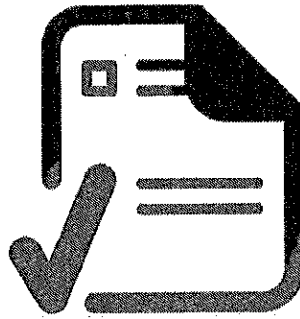

Modular Wetland System, Inc.

P. 760.433-7640

F. 760-433-3176

E. Info@modularwetlands.com

www.modularwetlands.com



Inspection Report Modular Wetlands System



Project Name _____
 Project Address _____ (city) (Zip Code)
 Owner / Management Company _____

For Office Use Only
(Reviewed By) _____
(Date) _____ Office personnel to complete section to the left.

Contact _____ Phone () _____
 Inspector Name _____ Date ____/____/____ Time ____ AM / PM

Type of Inspection Routine Follow Up Complaint Storm Storm Event in Last 72-hours? No Yes

Weather Condition _____ Additional Notes _____

Inspection Checklist

Modular Wetland System Type (Curb, Grate or UG Vault): _____ Size (22', 14' or etc.): _____

Structural Integrity:	Yes	No	Comments
Damage to pre-treatment access cover (manhole cover/grate) or cannot be opened using normal lifting pressure?			
Damage to discharge chamber access cover (manhole cover/grate) or cannot be opened using normal lifting pressure?			
Does the MWS unit show signs of structural deterioration (cracks in the wall, damage to frame)?			
Is the inlet/outlet pipe or drain down pipe damaged or otherwise not functioning properly?			
Working Condition:			
Is there evidence of illicit discharge or excessive oil, grease, or other automobile fluids entering and clogging the unit?			
Is there standing water in inappropriate areas after a dry period?			
Is the filter insert (if applicable) at capacity and/or is there an accumulation of debris/trash on the shelf system?			
Does the depth of sediment/trash/debris suggest a blockage of the inflow pipe, bypass or cartridge filter? If yes specify which one in the comments section. Note depth of accumulation in in pre-treatment chamber.			Depth:
Does the cartridge filter media need replacement in pre-treatment chamber and/or discharge chamber?			Chamber:
Any signs of improper functioning in the discharge chamber? Note issues in comments section.			
Other Inspection Items:			
Is there an accumulation of sediment/trash/debris in the wetland media (if applicable)?			
Is it evident that the plants are alive and healthy (if applicable)? Please note Plant Information below.			
Is there a septic or foul odor coming from inside the system?			

Waste:	Yes	No
Sediment / Silt / Clay		
Trash / Bags / Bottles		
Green Waste / Leaves / Follage		

Recommended Maintenance	
No Cleaning Needed	
Schedule Maintenance as Planned	
Needs Immediate Maintenance	

Plant Information	
Damage to Plants	
Plant Replacement	
Plant Trimming	

Additional Notes: _____



Maintenance Report

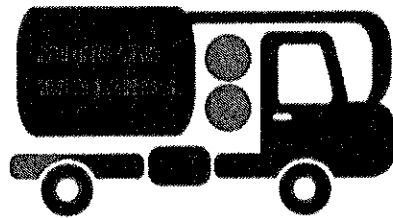

Modular Wetland System, Inc.

P. 760.433-7640

F. 760-433-3176

E. Info@modularwetlands.com

www.modularwetlands.com



Cleaning and Maintenance Report Modular Wetlands System



Project Name _____

Project Address _____ (city) (Zip Code)

Owner / Management Company _____

Contact _____ Phone () _____

Inspector Name _____ Date ____/____/____ Time _____ AM / PM

For Office Use Only

(Reviewed By) _____

(Date) _____

Office personnel to complete section to the left.

Type of Inspection Routine Follow Up Complaints Storm Storm Event in Last 72-hours? No Yes

Weather Condition _____ Additional Notes _____

Site Map #	GPS Coordinates of Insert	Manufacturer / Description / Sizing	Trash Accumulation	Foliage Accumulation	Sediment Accumulation	Total Debris Accumulation	Condition of Media 25/50/75/100 (will be changed @ 75%)	Operational Per Manufactures' Specifications (If not, why?)
	Lat: Long:	MWS Catch Basins						
		MWS Sedimentation Basin						
		Media Filter Condition						
		Plant Condition						
		Drain Down Media Condition						
		Discharge Chamber Condition						
		Drain Down Pipe Condition						
		Inlet and Outlet Pipe Condition						

Comments:

APPENDIX E



Product Warranty

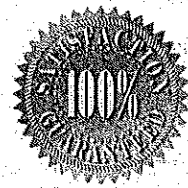

Modular Wetland System

Bio Clean, A Forterra Company products are engineered and manufactured with the intent to be considered as permanent infrastructure. Bio Clean, A Forterra Company warrants its products to be free of manufacturer's defects for a period of 5 years from the date of purchase. Bio Clean, A Forterra Company warrants that the materials used to manufacture its products will be able to withstand and remain durable to environmental conditions for a period of 5 years from the date of purchase. If a warranty claim is made and determined to be valid, Bio Clean, A Forterra Company will either repair or replace the product, at the discretion of Bio Clean, A Forterra Company. Warranty claims must be submitted, evaluated, and approved by Bio Clean, A Forterra Company for the claim to be determined to be valid. All warranty work and/or corrective action must be authorized by Bio Clean, A Forterra Company prior to beginning the work not covered by this warranty. There are no other warranties either expressed or implied other than what is specifically specified herein. Abusive treatment, neglect, or improper use of Bio Clean, A Forterra Company products will not be covered by this warranty.

(855) 566-3938



info@biocleanenvironmental.com

APPENDIX F

TECHNICAL EVALUATION REPORT

MODULAR WETLAND SYSTEM STORMWATER TREATMENT SYSTEM PERFORMANCE MONITORING

Prepared for
Modular Wetland Systems, Inc.

Prepared by
Herrera Environmental Consultants, Inc.



Note:

Some pages in this document have been purposely skipped or blank pages inserted so that this document will copy correctly when duplexed.

TECHNICAL EVALUATION REPORT

MODULAR WETLAND SYSTEM STORMWATER TREATMENT SYSTEM PERFORMANCE MONITORING

Prepared for
Modular Wetland Systems, Inc.
2972 San Luis Rey Road
Oceanside, California 92058

Prepared by
Herrera Environmental Consultants, Inc.
2200 Sixth Avenue, Suite 1100
Seattle, Washington 98121
Telephone: 206/441-9080

April 1, 2014

CONTENTS

Executive Summary	ES-1
Sampling Procedures	ES-1
Hydrologic Performance	ES-2
Water Quality Performance	ES-3
Basic Treatment	ES-3
Phosphorus Treatment	ES-3
Enhanced Treatment	ES-3
Introduction.....	1
Technology Description	3
System Overview	3
Physical Components	3
Structure.....	7
Inlet	7
Pre-Treatment Chamber	7
Media Cartridge Pre-Filter	8
Stormwater Conveyance into Wetland Chamber and High Flow Bypass	9
Wetland Chamber	9
Discharge Chamber.....	11
Treatment Mechanisms	11
Site Requirements	13
Necessary Soil Characteristics.....	13
Hydraulic Grade Requirements.....	13
Depth to Groundwater Limitations	13
Utility Requirements.....	13
Intended Application	13
Pretreatment Requirements.....	14
Current Installations	14
Sizing Methodology	14
Western Washington	15
Eastern Washington	15
Expected Treatment Capabilities.....	15
Estimated Design Life.....	18
Installation	18
Operation and Maintenance Requirements.....	19
Reliability	20
Other Benefits and Challenges	21
Sampling Procedures	23
Monitoring Design.....	23
Site Location	24
Monitoring Schedule	24

Test System Description	24
Test System Sizing.....	24
Maintenance Schedule	31
Hydrologic Monitoring Procedures	32
Bypass Flow Monitoring (AMWS-BP).....	32
Influent/Effluent Flow Monitoring Station (AMWS-OUT)	35
Precipitation Monitoring Station (AMWS-RG)	35
Monitoring Equipment Maintenance and Calibration	35
Water Quality Monitoring Procedures	36
Sediment Monitoring Procedures.....	37
Analytical Methods	38
Quality Assurance and Control Measures	38
Field Quality Assurance/Quality Control	38
Laboratory Quality Control	40
Data Management Procedures	40
Data Management Quality Control.....	41
Data Analysis Procedures.....	41
Hydrologic Data Analysis Procedures.....	41
Water Quality Data Analysis Procedures.....	41
Data Summaries and Analysis	43
Hydrologic Data.....	43
Historical Rainfall Data Comparison.....	43
Water Budget	44
Water Quality Data.....	47
Comparison of Data to TAPE Guidelines	49
Performance Evaluation	53
Particle Size Distribution	53
Basic Treatment	55
Phosphorus Treatment.....	59
Enhanced Treatment.....	60
Dissolved Zinc Treatment	63
Dissolved Copper Treatment	64
Other Parameters	70
Conclusions	75
References	77
Appendix A	MWS-Linear Installations in the United States
Appendix B	Quality Assurance Project Plan
Appendix C	Design Drawings
Appendix D	Hydrologic Quality Assurance Memorandum
Appendix E	Data Quality Assurance Review of MWS-Linear TAPE Performance Monitoring
Appendix F	Water Quantity and Quality Database
Appendix G	Field Forms
Appendix H	Individual Storm Reports
Appendix I	Laboratory Reports

TABLES

Table 1.	Recommended Plant List for MWS Units Installed in the Pacific Northwest.	11
Table 2.	MWS-Linear Sizing Table for Western Washington.	16
Table 4.	Methods and Detection Limits for Water Quality Analyses.	39
Table 5.	Monthly and Annual Precipitation Totals (in inches) for 2012-2013 at the MWS-Linear Monitoring Site, Compared to Historical Totals at Portland Airport.....	44
Table 6.	Summary Statistics for Storms That Produced Bypass Flow at the AMWS Test System from April 1, 2012, Through May 31, 2013.	45
Table 7.	Comparison of Precipitation Data from Sampled Storm Events at the AMWS Test System to Storm Event Guidelines in the TAPE.....	50
Table 8.	Comparison of Flow-weighted Composite Data from Sampled Storm Events at the AMWS Test System to Criteria in the TAPE.....	52
Table 9.	Total Suspended Solids Concentrations and Removal Efficiency Estimates for Valid Sampling Events at the AMWS Test System.....	57
Table 10.	Total Phosphorus Concentrations and Removal Efficiency Estimates for Valid Sampling Events at the AMWS Test System.....	61
Table 11.	Dissolved Zinc Concentrations and Removal Efficiency Estimates for Valid Sampling Events at the AMWS Test System.....	65
Table 12.	Dissolved Copper Concentrations and Removal Efficiency Estimates for Valid Sampling Events at the AMWS Test System.....	67
Table 13.	Summary Results for Screening Parameters.....	71

FIGURES

Figure 1.	Vicinity Map of the MWS-Linear Monitoring Site (AMWS) at the Albina Maintenance Facility in Portland, Oregon.	2
Figure 2.	Cross-section of Typical Offline MWS-Linear System with Piped and Grated Inlet Flow.	4
Figure 3.	Design Details of Half Size MWS-Linear system with Piped Inlet Flow.	5
Figure 4.	Perspective Rendering of Example MWS-Linear System with Piped Inflow and Upstream Structure.	6
Figure 5.	Rendering of Media Cartridge Pre-filters (Right) and Water Routing into the Wetland Chamber (Left).	8
Figure 6.	Site Map of the MWS-Linear Monitoring Site (AMWS) at the Albina Maintenance Facility in Portland, Oregon.	25
Figure 7.	Plan View Diagram of the MWS-Linear Monitoring Site (AMWS).	27
Figure 8.	Cross-section of the MWS-Linear Monitoring Site (AMWS).	29
Figure 9.	Photos of Sediment Loading and Pre-filters Used at the AMWS Monitoring Site.	33
Figure 10.	Temporal Plot of Peak Treated Flow Rate during Bypass and Storm Precipitation Depth.	48
Figure 11.	Influent PSD Results from Chemoptix (First 18 Samples).	53
Figure 12.	Influent PSD Results from Analytical Resources, Inc. (Last 10 Samples).	54
Figure 13.	TSS Removal (%) as a Function of Average Treated Flow Rate.	59
Figure 14.	TP Removal (%) as a Function of Average Treated Flow Rate.	63
Figure 15.	Dissolved Zinc Removal (%) as a Function of Average Treated Flow Rate.	69
Figure 16.	Dissolved Copper Removal (%) as a Function of Average Treated Flow Rate.	70

EXECUTIVE SUMMARY

Modular Wetland System - Linear filtration system (MWS-Linear) is a water quality treatment system consisting of a pre-treatment chamber, a media cartridge pre-filter, a wetland biofiltration chamber, and an outlet control device. The system is housed in a precast concrete vault and can be designed in numerous configurations including piped, curb or grated inlet structures.

From April 2012 through May 2013, Herrera Environmental Consultants, Inc. (Herrera) conducted hydrologic and water quality monitoring of a MWS-Linear for Modular Wetland Systems, Inc. at one approved test installation in Portland, Oregon. Herrera conducted this monitoring to obtain performance data to support the issuance of a General Use Level Designation (GULD) for the MWS-Linear by the Washington Department of Ecology (Ecology). Monitoring was performed in accordance with procedures described in *Guidance for Evaluating Emerging Stormwater Treatment Technologies; Technology Assessment Protocol - Ecology (TAPE)* (Ecology 2011).

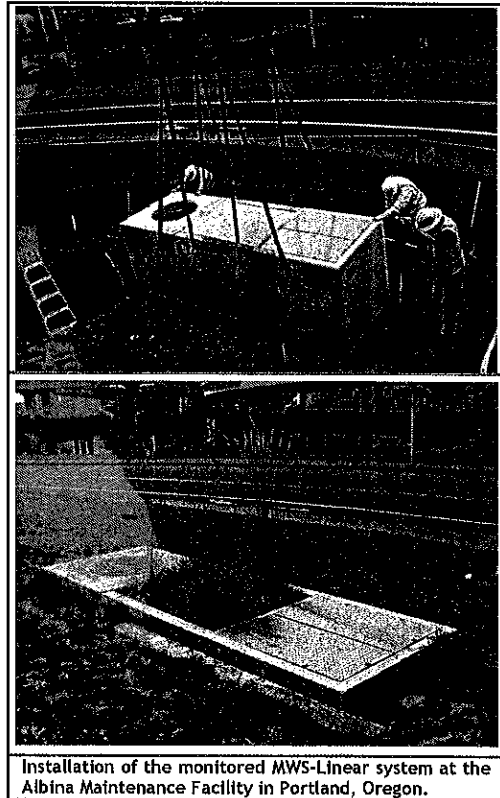

This technical evaluation report (TER) was prepared by Herrera to demonstrate satisfactory performance of the MWS-Linear in meeting the minimum requirements as specified by Ecology (2011) for basic treatment, phosphorus treatment, and enhanced treatment.

Sampling Procedures

To evaluate the stormwater treatment performance of the MWS-Linear based on Ecology's TAPE guidelines, a test system was installed at the Portland Bureau of Environmental Services Albina Maintenance Facility in Portland, Oregon (Figure 1). This system is identified herein as the Albina Modular Wetland System (AMWS). Automated monitoring equipment was installed to continuously measure influent, effluent, and bypass flow volumes. Automated equipment was used to collect flow-weighted composite samples of the system's influent and effluent during 28 separate storm events in the monitoring period. The collected flow-weighted composite samples were analyzed for the following water quality parameters:

- Total suspended solids (TSS)
- Particle size distribution (PSD) (influent only)

- Total and dissolved copper
- Total and dissolved zinc
- Total phosphorus (TP)
- Soluble reactive phosphorus (SRP)
- Hardness
- pH

These data were subsequently analyzed in the following ways:

- Computation of pollutant removal efficiencies with bootstrap confidence intervals
- Statistical comparisons of influent and effluent concentrations
- Correlation analysis to examine the influence of treated flow rate on system performance

These results were then compared to TAPE minimum requirement goals for basic, phosphorus, and enhanced treatment.

Hydrologic Performance

The water quality treatment goal for the test system was to capture and treat 91 percent of the average annual runoff volume. Monitoring data showed that stormwater bypassed the AMWS test system during 49 out of 81 monitored events during the 14-month monitoring period. The system was able to treat 75 percent of the total volume that entered the system over this period. Consequently, the goal of treating 91 percent of the volume from the site was not achieved. This was most likely due to the high level of fine clay content of the runoff resulting in clogging of the media cartridge pre-filter located in the pre-treatment chamber (see *Maintenance Schedule*). In addition, analysis of the flow data at the end of the project indicated that the system was undersized for the basin. On average, a 1.54-inch storm (6-month storm for the region) produced a 102.6 gallons per minute peak discharge. The system was only sized to treat 41 gallons per minute.

During the monitoring period, it appeared that the wetland chamber's biofiltration media did not experience a substantial decrease in flow capacity indicating that the pre-treatment prevented the wetland media from clogging. There was a negative trend over time for treated flow rate during bypass due to accumulation of fine sediment on the pre-filter media. On average, the pre-filters required changing every 2 to 3 months. This frequency of maintenance was due, in large part, to the high clay content of the runoff from the Albina site. Under more typical stormwater loading conditions, it is anticipated that the pre-filter media will last 6 to 24 months before the media is required to be removed and replaced. Furthermore, since no flow decrease was observed in the WetlandMedia, it is anticipated that the wetland chamber will not require maintenance for several years. It should also be noted that with the inclusion of additional pre-filter cartridges the maintenance interval would

likely have been extended. The required number of pre-filters should be determined on a site specific basis.

Water Quality Performance

Basic Treatment

The basic treatment goal in the TAPE guidelines is 80 percent removal of total suspended solids for influent concentrations ranging from 100 to 200 milligrams per liter (mg/L). For concentrations less than 100 mg/L, facilities must achieve an effluent goal of 20 mg/L pursuant to TAPE guidelines.

Total suspended solids removal rates ranged from 61 to 98 percent, with a mean value of 84.9 percent. The upper 95 percent confidence interval about the mean effluent concentration was 12.8 mg/L. The TAPE effluent goal is 20 mg/L or less, therefore the Basic water treatment criteria were met. Analyses of flow and water quality data indicated the treatment goal for total suspended solids removal was met up to and through the design flow rate of 41 gallons per minute (gpm) (equivalent of 1 gpm/ft² of media loading rate) for the MWS-Linear and even exceeded treatment goals at 50 gpm (1.21 gpm/ft²).

Phosphorus Treatment

The phosphorus treatment goal in the TAPE guidelines is 50 percent removal of total phosphorus for influent concentrations ranging from 0.1 to 0.5 mg/L.

A bootstrap estimate of the lower 95 percent confidence limit (LCL95) of the mean total phosphorus reduction was 61.7 percent. Consequently, it can be concluded that the mean percent removal was significantly greater than the 50 percent goal specified in the TAPE guidelines. The system also exhibited removal rates greater than 50 percent up to and through the design flow rate of 41 gpm and even exceeded treatment goals at 50 gpm (1.21 gpm/ft²).

Enhanced Treatment

The dissolved zinc treatment goal in the TAPE guidelines is 60 percent removal for influent concentrations ranging from 0.02 to 0.3 mg/L. The dissolved copper treatment goal is 30 percent removal for influent concentrations ranging from 0.005 to 0.02 mg/L. The lower 95 percent confidence limit of the mean percent removal was 60.5 and 32.5 percent for dissolved zinc and dissolved copper, respectively. These data indicate that the TAPE removal criteria were met for both dissolved zinc and dissolved copper. Treatment above the TAPE criteria of 60 percent removal was evident in the dissolved zinc results from treated flow rates up to and including the design flow rate of 41 gpm. Dissolved copper treatment was only evident up to 28 gpm; however, if lab data from 2007 are added to the data set, the flow rate at which 30 percent dissolved copper reduction can be achieved increases to the design flow rate of 41 gpm (1 gpm/ft² of media).



INTRODUCTION

The Modular Wetland Systems - Linear (MWS-Linear) is a structural stormwater treatment system developed by Modular Wetland Systems, Inc. The MWS-Linear utilizes a multi-stage treatment processes, including a pre-treatment chamber that houses a settling basin and a media cartridge pre-filters that are designed to remove coarse to fine sediment and hydrocarbons from entering the subsequent wetland chamber. The wetland chamber media provides chemical and biological filtration and secondary physical filtration. This system is housed in a modular precast concrete structure that can be designed in many inlet configurations. The MWS-Linear provides water quality treatment of captured flows through the processes of separation, sedimentation, filtration, adsorption, absorption, sequestration, volatilization, ion exchange, biological remediation, and uptake.

The Washington State Department of Ecology (Ecology) has established specific use level designations for emerging stormwater treatment technologies like the MWS-Linear in accordance with guidelines that are identified by Ecology (2011) in *Technical Guidance for Evaluating Emerging Stormwater Treatment Technologies: Technology Assessment Protocol - Ecology (TAPE)*.

There are three use level designations: pilot, conditional, and general. Pilot and conditional use level designations allow limited application of emerging stormwater treatment technologies in western Washington to facilitate field testing. If the testing shows that the treatment technology meets minimum treatment goals as identified in the TAPE, Ecology may issue a general use level designation (GULD) for the treatment technology, permitting its widespread use in Washington.

TAPE guidelines indicate that a technical evaluation report (TER) must be completed for any stormwater treatment system under consideration for a GULD. Specifically, the TER should document treatment performance of a technology to show that it will achieve Ecology's performance goals for target pollutants, as demonstrated by field testing performed in accordance with the TAPE.

This document is the TER for the MWS-Linear, and was prepared by Herrera -to demonstrate satisfactory performance of the MWS-Linear in meeting treatment goals specified by Ecology (2011) for basic treatment, total phosphorus and enhanced treatment. It specifically presents data from a test MWS-Linear installed at the Portland Maintenance Bureau Albina Maintenance Facility (Figure 1). This monitoring was performed over a 14-month period, from April 14, 2012, through May 31, 2013.

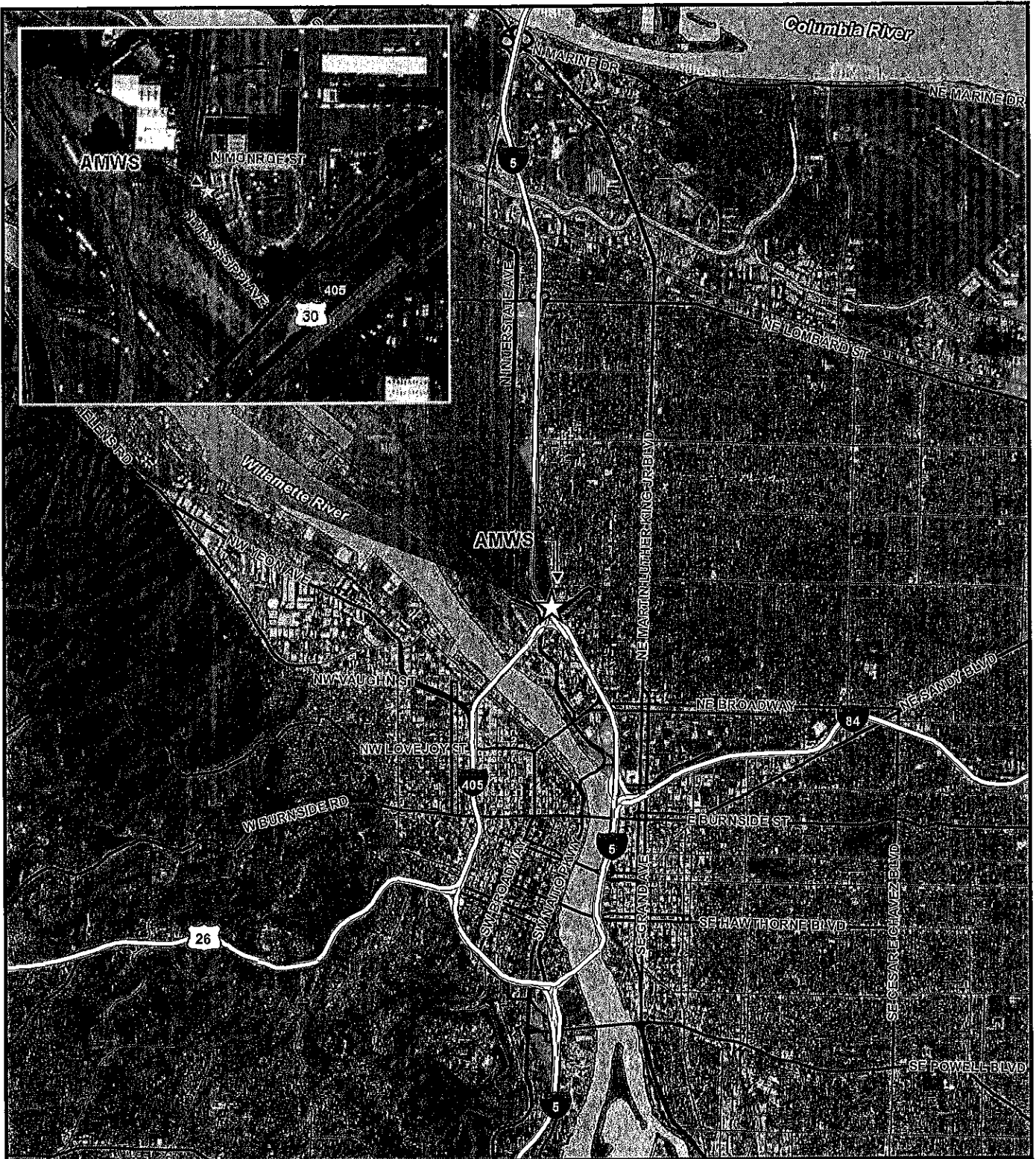

Legend

- ☆ Project location
- Highway
- Street
- River

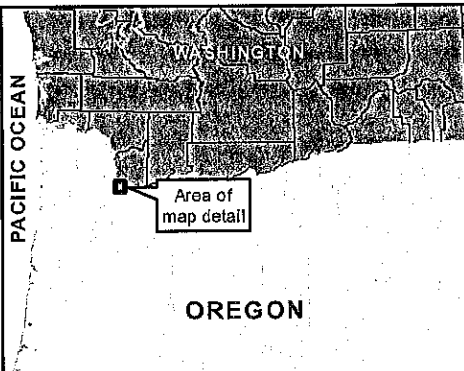

Figure 1. Vicinity map of the MWS - Linear monitoring site (AMWS) at the Albina Maintenance Facility in Portland, Oregon.



Aerial: Metro Data Resource Center (2006); Bing (2013)

K:\Project\08-04 184-000\Project\vicinity_map.mxd

TECHNOLOGY DESCRIPTION

The MWS-Linear stormwater filtration system provides water quality treatment of captured flows through several physical, biological, and chemical unit processes. This section describes the system's physical components, treatment processes and removal mechanisms, sizing methods, expected treatment capabilities, expected design life, and required maintenance procedures.

System Overview

The MWS-Linear can be used in a variety of configurations, including curb, grate, and vault-type (piped) designs (Figures 2, 3, and 4). New construction and stormwater retrofit projects can utilize the modular design of the MWS-Linear in place of standard catch basin structures, rain gardens, bioretention cells, media filters, or other treatment devices. A variety of inlet, bypass, and wetland chamber designs are available for the MWS-Linear and can be easily be adapted for different stormwater drainage system designs and needs. However, the hydraulics within the system itself and the treatment processes are the same for each of these configurations.

Stormwater runoff enters the MWS-Linear via pipe, curb, or grate opening. For the MWS-Linear with a grate or curb-type opening, a catch basin filter insert facilitates the removal of gross solids and floatable trash prior to the stormwater entering the pre-treatment chamber. For the MWS-Linear with pipe openings (such as the study unit presented herein), stormwater enters the pre-treatment chamber directly. The pre-treatment chamber is specifically designed to settle out trash and litter, gross solids, and suspended sediment. Stormwater is then treated by the media cartridge pre-filters, which removes several pollutants, fine TSS, and hydrocarbons to protect the wetland chamber from clogging. After the stormwater moves through the media cartridge pre-filter, it enters the wetland chamber, which acts as a biofilter and is the main treatment component of the system. The MWS-Linear processes stormwater horizontally through the biofiltration media contained within the wetland chamber. Within this wetland chamber, a combination of physical, chemical, and biological mechanisms remove additional particulate and soluble pollutants. Treated runoff leaving the wetland chamber is controlled by a downstream orifice or flow control structure in the discharge chamber and leaves the system via the discharge chamber piping. The hydraulic conductivity of the biofiltration media contained within that wetland chamber is higher than the set orifice rate. In this manner the biofiltration media has a built-in hydraulic safety factor to ensure sustained treatment flow rates.

Physical Components

The MWS-Linear consists of a series of treatment components, beginning with a catch basin filter insert (for grate and curb-type configurations), a pre-treatment chamber, the BioMediaGREEN pre-filter, and finishing with a wetland chamber and discharge chamber. The

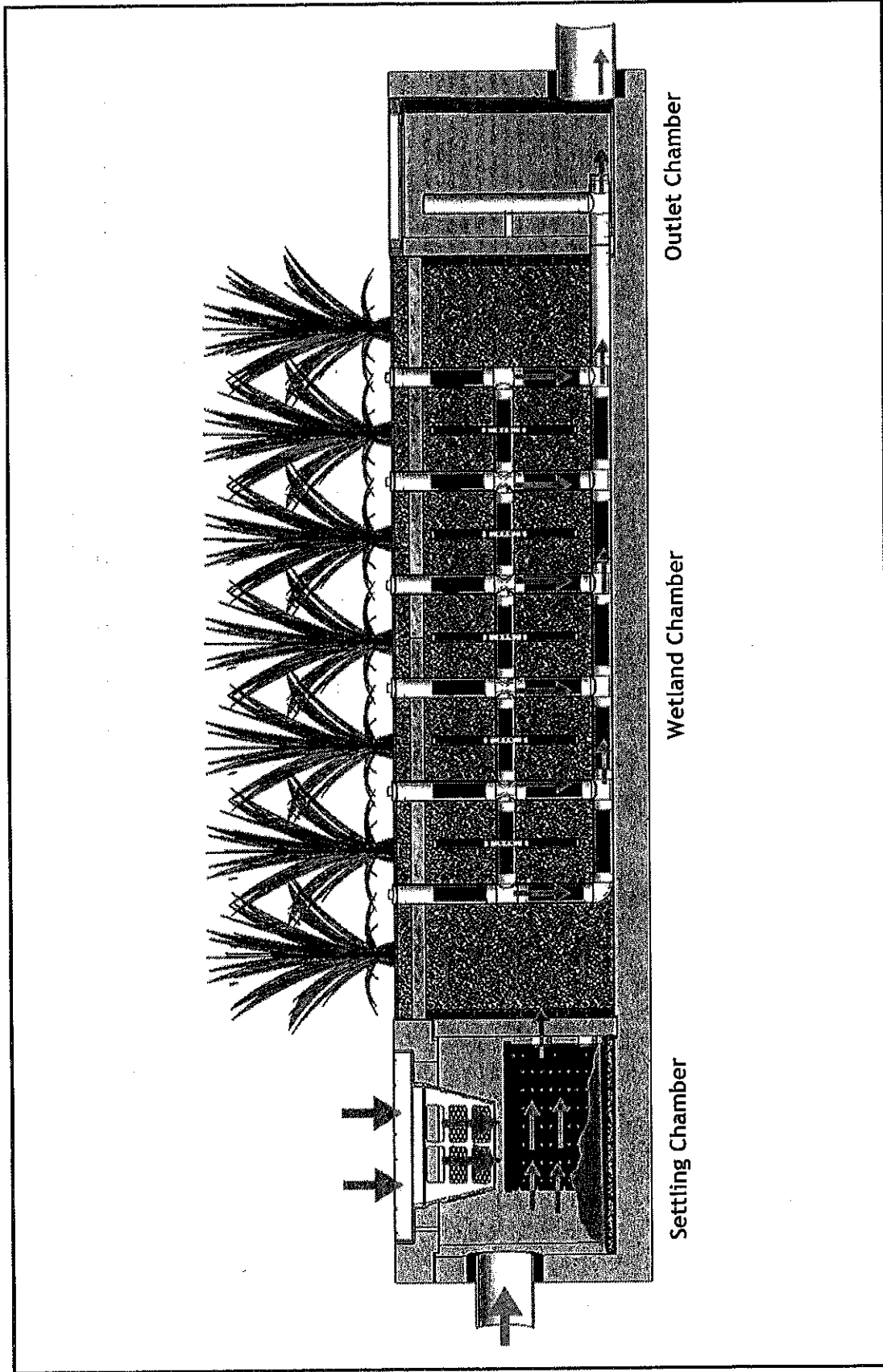

Figure 2. Cross-section of Typical Offline MWS-Linear System with Piped and Grated Inlet Flow.

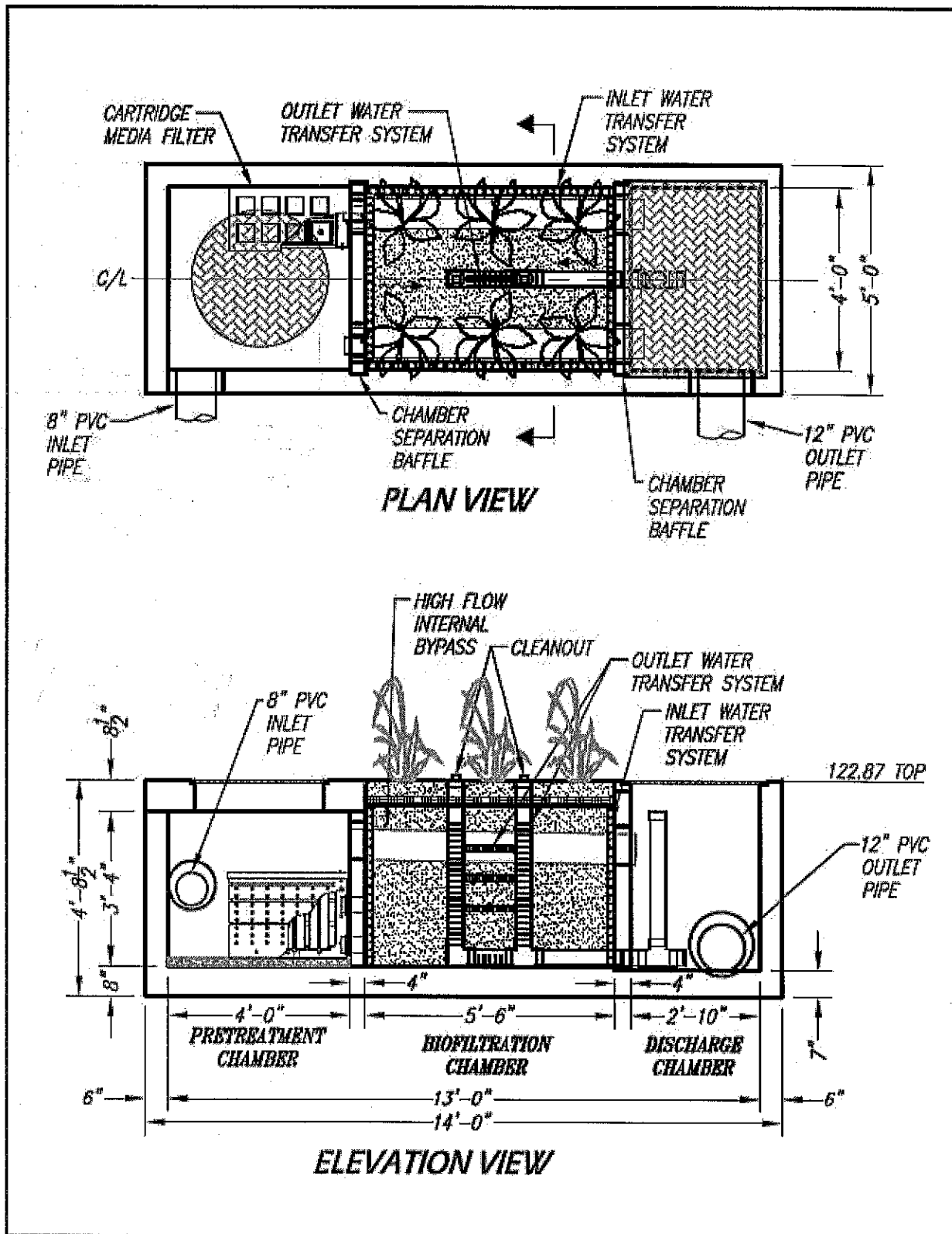

Figure 3. Design Details of Half Size MWS-Linear system with Piped Inlet Flow.

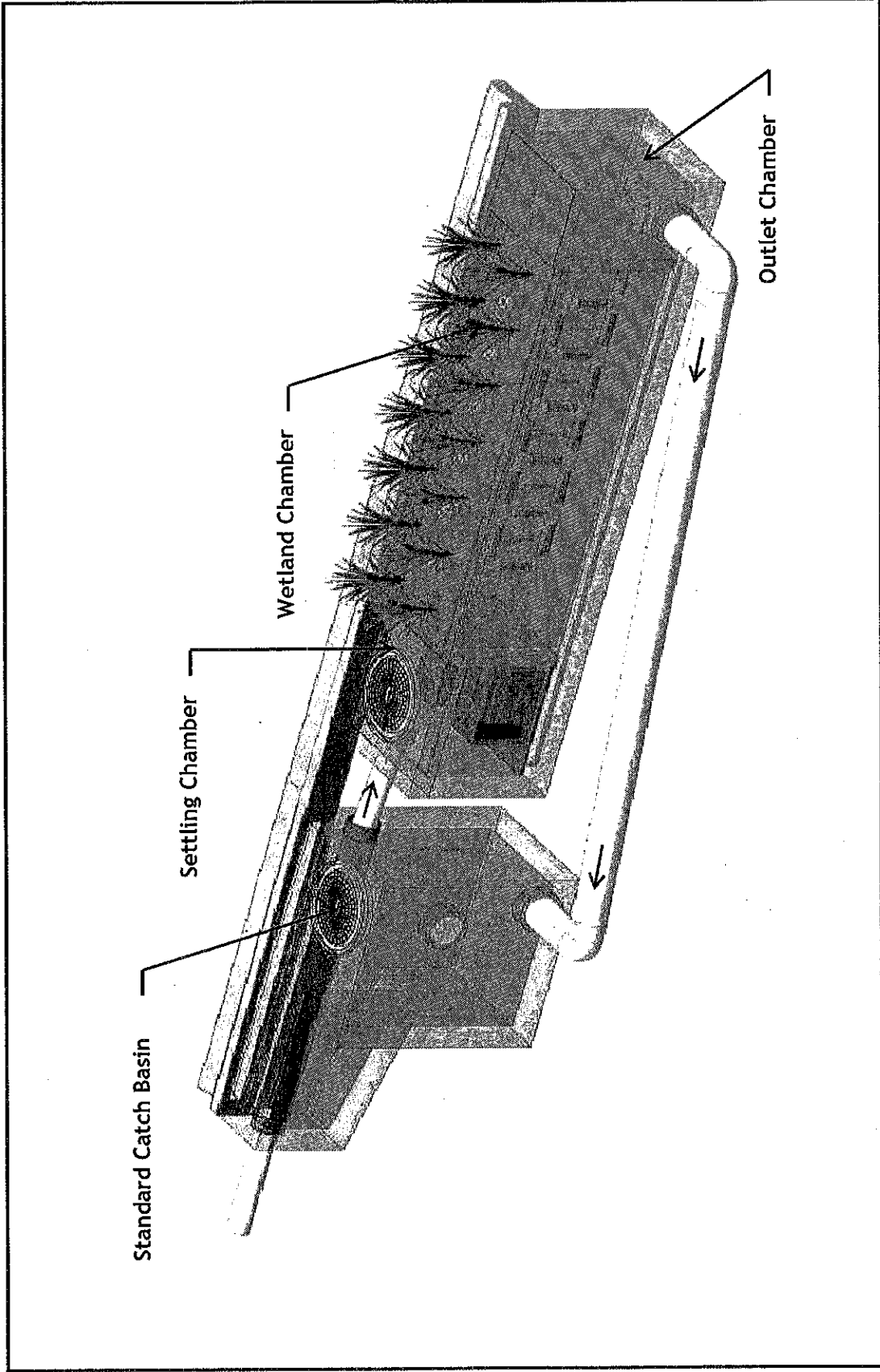

Figure 4. Perspective Rendering of Example MWS-Linear System with Piped Inflow and Upstream Structure.

discharge chamber collects flow from the wetland chamber and internal bypass pipes and routes stormwater to the outlet pipe.

The BioMediaGREEN can easily be removed and replaced from the media cartridge pre-filters to maintain the treatment performance within an acceptable range; the catch basin filter insert, pre-treatment chamber, and media cartridge pre-filter improve the wetland chamber performance by minimizing the pollutant loading on the biofiltration media. The primary components of the MWS-Linear are described below.

Structure

The MWS-Linear is a modular, precast concrete structure. Each MWS-Linear concrete structure is available in numerous lengths and widths to accommodate flow or volume requirements. There are several alternative configurations and the MWS-Linear can be adapted to a variety of site conditions. Each complete unit weighs approximately 9,000 to 70,000 pounds and requires a boom crane for installation.

Runoff can enter the system via built-in grate or curb inlet or enter directly into the pre-treatment chamber via pipe. The system has been designed to accommodate different depths without changing biofiltration media thickness or stormwater detention time. The system's horizontal flow biofilter and inlet configurations also allow it to be utilized in volume-based configurations downstream of storage BMPs, such as detention basins, ponds, or underground facilities.

The MWS-Linear is constructed with non-corrosive materials. All internal piping is SD35 or SD40 PVC. Catch basin filter insert components, including mounting hardware, fasteners, support brackets, filtration material, and support frame are constructed of non-corrosive materials (316 stainless steel and UV protected/marine grade fiberglass). Fasteners are stainless steel and the primary filter mesh is stainless steel welded screens. Media cartridge pre-filters are constructed of high strength HDPE. Mounts are constructed of stainless steel. BioMediaGREEN is a sorptive rock substrate and is inert and non-corrosive. The drain down filter cover is constructed of high strength HDPE and the hinge and mount are constructed of stainless steel.

Inlet

The MWS-Linear is available with a built-in grate or curb opening and/or can accept runoff via pipe. In the grate or curb type configuration, a catch basin filter is mounted directly under the opening to intercept trash and debris as well as coarse or large sediment. The size and shape of the catch basin filter varies from model to model. The catch basin filter utilizes progressively finer screen sizes to facilitate removal and maintain flow rates. It also possesses built-in internal openings for bypassing higher flows.

Pre-Treatment Chamber

The pre-treatment chamber is located below the inlet. The settling area within this chamber has been specifically designed to provide secondary pre-treatment of stormwater to settle large and coarse suspended solids.

Media Cartridge Pre-Filter

The media cartridge pre-filter is designed to house BioMediaGREEN but can use other various types of filter media. BioMediaGREEN is a proprietary engineered filter media made of a unique combination of inert, naturally occurring minerals. The BioMediaGREEN is designed as lightweight porous blocks, which are then cut into 1- by 1-centimeter cubes, and are packed into eight (8) separate cells around a center drain tube in each filter cartridges (Figure 5). This natural product is non-combustible, stable, biodegradable, and inert, having no known adverse effects on the environment.

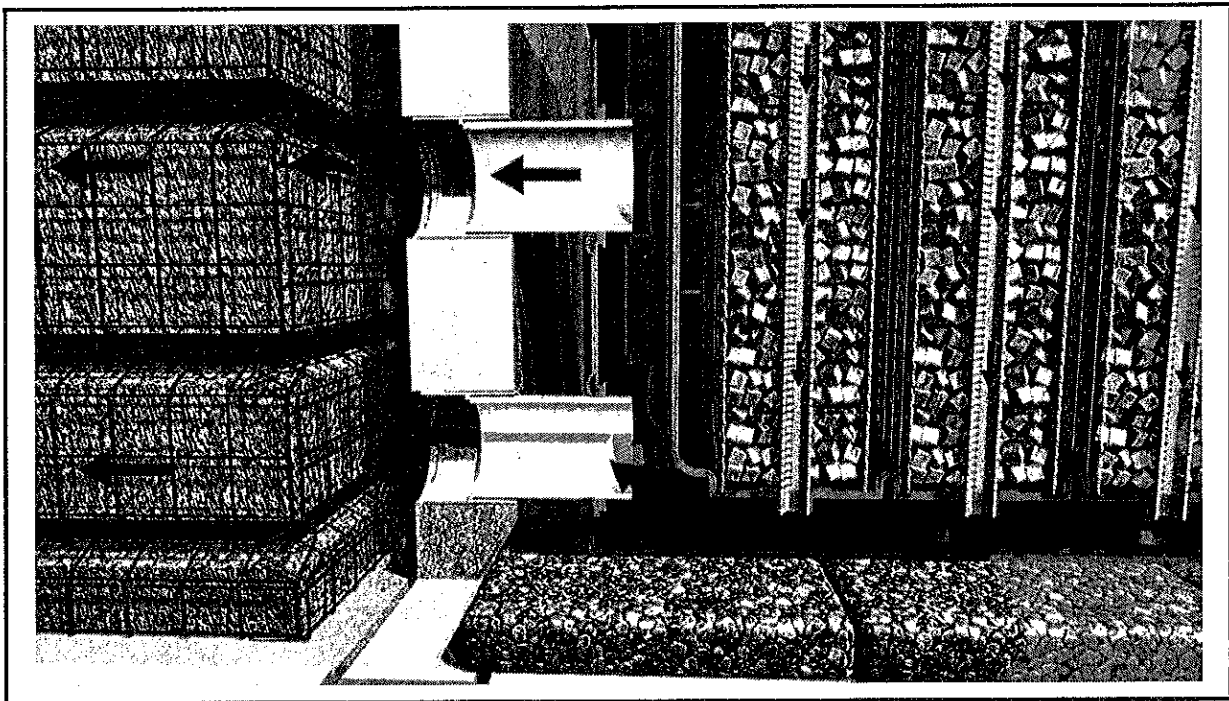

Figure 5. Rendering of Media Cartridge Pre-filters (Right) and Water Routing into the Wetland Chamber (Left).

The highly porous nature of BioMediaGREEN allows stormwater to easily flow around and through the cubes. The hydraulic conductivity of BioMediaGREEN is rated at 595 inches per hour, but stormwater also flows around each cube, so the actual hydraulic conductivity of the cartridges is much higher than the stated flow above.

BioMediaGREEN cubes also contain a high surface area to volume ratio, which promotes elevated levels of physical, chemical, and biological processes to treat stormwater. BioMediaGREEN filter cubes are designed to capture high levels of soluble and insoluble pollutants and hydrocarbons, including oils and grease, gasoline, diesel, polycyclic aromatic hydrocarbons (PAHs), and other organic chemicals. BioMediaGREEN cubes have the physical ability to block and filter trash, litter, vegetative matter, sediment, total suspended solids (TSS), total and dissolved metals, nutrients, and bacteria.

Maintenance of the media cartridge pre-filter is simple, and only requires access to the pre-treatment chamber (cartridges do not need to be removed for maintenance). To maintain,

the lid of the cartridge is removed, the used BioMediaGREEN cubes are removed from each cell within the cartridge, the cartridge housing cleaned, new BioMediaGREEN cubes added, and the cartridge lid replaced. BioMediaGREEN cubes are light green in color when new, and turn a darker color as pollutants and sediment are absorbed onto its surface from untreated stormwater. Maintenance crews can easily determine if the filter cubes need replacement by virtue of this color change. The BioMediaGREEN cubes can typically be disposed of in an ordinary landfill (local regulations may apply).

The number and size of media cartridge pre-filters is customizable and can range from one to dozens depending on the treatment flow rate and influent solids loading. Recommendations for pre-filter configurations are provided in the *Sizing Methodology* section.

Stormwater Conveyance into Wetland Chamber and High Flow Bypass

After stormwater has passed through the pre-treatment chamber's settling area and media cartridge pre-filter, it is transferred out of the cartridge into a series of 4-inch diameter PVC SD35 manifolds (Figure 5) that lead to the wetland chamber's peripheral void area (known as the inlet water transfer system and described in the next section).

The MWS-Linear is available with one or more high flow bypass pipes near the top of the pre-treatment chamber for internal bypass. External bypass configurations are also available. All bypass configurations are used to convey stormwater around the wetland chamber and to the discharge chamber or downstream tie-in points. High flow bypass occurs when the MWS-Linear's flow capacity is exceeded. Alternative bypass configurations are also available for smaller and larger MWS-Linear models that include a built-in internal bypass weir wall. Since the wetland chamber is separated from the pre-treatment and discharge chamber, internal bypass has no effect on performance. Therefore, the wetland chamber only experiences the orifice controlled water quality flow rate, as determined during MWS-Linear sizing for each specific contributing drainage area.

Wetland Chamber

The wetland chamber is the primary stage of water treatment for the MWS-Linear. The system employs an innovative peripheral (perimeter) 2" void area on all four sides of the biofiltration media that extends to at least the height of the wetland chamber's operating hydraulic gradient level (HGL). This is known as the inlet water transfer system. Incoming stormwater surrounds the biofiltration media bed within the void space and migrates towards a series of vertically extended underdrain or collection piping located in the center of the cell. This is known as the outlet water transfer system. As such, it operates similar in fashion to a radial cartridge filter. The horizontal flow path through the media from an outside perimeter maximizes the available surface area and thus, treatment flow capacity. Because flow through the media is horizontal, the media thickness from influent point to effluent point remains constant, regardless of the height of the wetland chamber. Therefore, shallow or deeper systems can be specified without compromising treatment efficiencies associated with downward flow systems such as rain garden, bioretention systems and the like - all of which require the removal of media to accommodate shallow requirements.

The wetland chamber is filled with an engineered organic-free sorptive biofiltration media called WetlandMedia. The WetlandMedia is designed to maximize physical, chemical, and

biological treatment processes along with supporting live vegetation. The WetlandMedia also includes a layer of plant propagation media above the active treatment zone to help with establishing vegetation. For example, the MWS-Linear Model #MWS-L-4-21 has a wetland chamber that is 4 feet wide by 13.8 feet long and has a physical chamber height of 4 feet. The overall O.D. dimensions of this model including the concrete vault, pre-treatment, and discharge chamber is 5 by 22 by 4.8 feet. The active media surface area of the wetland chamber for this model is 117 square feet at standard height. Radial subsurface flow through the WetlandMedia provides a combination of physical, chemical, and biological filtration processes for treatment of stormwater before it enters the discharge chamber. As interstitial voids in the media begin to slowly accrete suspended solids from the stormwater, the media becomes more carbon and nutrient rich. This results in more vigorous plant growth and increased micro-biological processing of the stormwater. The ecosystem that develops around the roots of the plants (or rhizosphere) is a complex combination of oxygen rich bacteria, fungi, and carbonaceous plant material. Biological growth and oxygen rich organisms mobilize, metabolize, and decompose influent pollutants and contribute to the overall treatment performance of the MWS-Linear.

After stormwater passes through the WetlandMedia it enters a series of perforated, 4-inch diameter, SD35 PVC outflow chamber transfer pipes, located along the chamber's central axis (Figure 3). The vertically extending perforated under drain pipes join to a common solid horizontal pipe manifold along the bottom of the wetland chamber. This pipe collects sub-surface flow from the wetland chamber and conveys the treated stormwater to the discharge chamber through an orifice that regulates treatment flow and loading rates through the wetland chamber.

Wetland Chamber Vegetation

A wide variety of upland or wetland plant species can be planted on the surface of the wetland chamber. Vegetation can be selected based on aesthetics, local climatic conditions, traffic safety, and maintenance considerations. However, adequate time (months) is necessary to allow for the plant roots and eco-biological organisms to colonize and to be well established within the wetland chamber. Table 1 provides a recommended plant palette for installations in the Pacific Northwest. For installations outside this area, the manufacturer will recommend other appropriate plants.

Vegetation was initially planted in mid-July of 2011, only 8 months prior to testing. The MWS-Linear had a physical height of 4 feet, yet due to the height limitation of the external bypass weir, the WetlandMedia was saturated to a depth of only 2.3 feet. The distance from the top of the unit, in which the vegetation is planted, and the active WetlandMedia was 1.6 feet. Based upon the observations of plant growth rate and root establishments rates for the variety of the plants utilized, it was determined that the roots did not reach the active treatment zone during at least the first years of testing from April 2012 to April 2013. Consequently, it can be concluded that the systems physical, chemical, and biological treatment of the stormwater was primarily a function of the WetlandMedia and the microbes and beneficial bacterial that live within in it and less as function of the vegetation's root systems.

Table 1. Recommended Plant List for MWS Units Installed in the Pacific Northwest.	
Scientific Name	Common Name
Grasses and Sedges	
<i>Bromus carinatus</i>	California brome grass
<i>Bromus sitchensis</i>	Alaska brome
<i>Bromus vulgaris</i>	California brome grass
<i>Carex exicata</i>	Blister sedge
<i>Carex stipata</i>	Awlfruit sedge
<i>Elymus glaucus</i>	Blue wildrye
<i>Festuca californica</i>	California fescue
<i>Festuca occidentalis</i>	Western fescue
<i>Hordeum brachyantherum</i>	Meadow barley
Forbes (Flowering Plants)	
<i>Aquilegia formosa</i>	Red columbine
<i>Aster suspicatus</i>	Douglas' aster
<i>Camassia leichtlinii</i>	Leichtlin's camas
<i>Clarkia amoena</i>	Farewell to spring
<i>Delphinium leucophaeum</i>	Pale larkspur
<i>Epilobium angustifolium</i>	Fireweed
<i>Huechera micrantha</i>	Smallflowered alumroot
<i>Iris tenax</i>	Oregon iris
<i>Mimulus guttatus</i>	Yellow monkey-flower
<i>Sisyrinchium idahoense</i>	Blue-eyed grass

Discharge Chamber

The discharge chamber collects treated stormwater from the outlet water transfer system as well as stormwater from high flow bypass pipes or weirs. The outlet water transfer system connects to the discharge chamber via a 4-inch PVC pipe to an orifice or flow control structure housed in the discharge chamber (Figure 3). The orifice is set to discharge stormwater at a calculated treatment flow rate equal to and not exceeding the design wetland loading rate given the media surface area for any size or height system. For example, the orifice insures the system is operating at 100 in/hr or 1.03 gpm at peak capacity and never at a higher flow rate to ensure optimal performance. The flow through the orifice is also much less than the hydraulic conductivity of the media itself and therefore providing a built-in safety factor against potential clogging over several years or operation. Flows collected in the discharge chamber are routed to a discharge pipe.

Treatment Mechanisms

The MWS-Linear provides water quality treatment of captured flows through physical, chemical, and biologic unit processes. Runoff treatment is achieved through screening,

sedimentation, filtration, absorption, adsorption, sequestration, sorption, biological remediation, and uptake.

Screening

For MWS-Linear grate-type systems, the catch basin insert located at the inlet intercepts the majority of floatable and gross solids, trash and litter, and coarse sediment before entering the pre-treatment chamber. The catch basin insert filter is designed with multiple levels of various screen sizes to remove pollutants.

Sedimentation

The MWS-Linear contains a pre-treatment chamber below the inlet, and has been designed to promote gravity or hydrodynamic settling of entrained particles. Settling of large particles in the pre-treatment chamber improves the system's performance as well as extends the life of the media cartridge pre-filter. The amount of sedimentation is a function of particle density, size, water density and viscosity, internal turbulence, and residence time.

Filtration

Particulates are physically removed from suspension as they contact the BioMediaGREEN contained within in media cartridge pre-filter(s). Pollutant removal rates achieved through the cartridges alone are a function of the stormwater composition, flow, and pre-treatment effectiveness. Filtration is also the primary physical unit process or mechanism in the wetland chamber. The 3- to 5-millimeter WetlandMedia in the wetland chamber creates a non-linear and torturous flow path which enhances contact between the stormwater and the various filtration media.

Adsorption

Unlike filtration, where physical processes control removal of sediment from suspension, adsorption relies on opposing surface charges of the BioMediaGREEN filter media and wetland chamber media and dissolved constituents to remove pollutants from stormwater. The BioMediaGREEN filter media is designed with a high surface area so that the binding sites are not exhausted through its expected life cycle. In addition, both the WetlandMedia and the BioMediaGREEN possess a high cation exchange capacity that promotes the effective removal of positively charged dissolved pollutants (including transition and heavy metal ions) from the incoming stormwater.

Biological Remediation

Bacterial growth, supported by the root system in the wetland chamber, performs a number of treatment processes. These vary as a function of moisture, temperature, pH, salinity, and pollutant concentrations. Biologically available forms of nitrogen, phosphorus, and carbon are actively taken into the cells of vegetation and bacteria, and used for metabolic processes (i.e., energy production and growth). Nitrogen and phosphorus and many heavy metals common to stormwater are actively taken up as micronutrients that are vital for a number of cell functions, growth, and energy production. These biological processes remove metabolites from the media during and between storm events, making the media available to capture more nutrients from subsequent storm events.

Aerobic and anaerobic soil organisms in the wetland chamber break down, decompose, sequester, and volatilize a wide array of organic compounds into less toxic forms or completely break them down into carbon dioxide and water (Means and Hinchee 1994). Bacteria can also cause metals to precipitate out as salts, bind them within organic material, and accumulate metals in nodules within the cells. Finally, plant growth may metabolize many pollutants, sequester them or rendering them less toxic (Reeves and Baker 2000).

Site Requirements

Necessary Soil Characteristics

Specific underlying soil characteristics are not required for the MWS-Linear, since it is a self-contained, watertight system and is fully enclosed. However, the manufacturer does require that the MWS-Linear system be installed on a level bed of gravel 6 inches in depth (see Installation Manual). The system can be installed with open holes in the bottom of the discharge chamber to transfer treated stormwater to soils below to maximize infiltration if desired.

Hydraulic Grade Requirements

The MWS-Linear is completely passive and requires a minimum of 4.13 feet fall from the top of the unit to pipe invert outlet for standard models. Taller and shorter units are available for areas with limited fall conditions. For piped flows, water entering the system can come in with as little as 6 inches of flow between inflow pipe and outflow pipe. At the same time, the internal the internal or external bypass must be at an elevation equal to the operating hydraulic gradient level (HGL) of the system. Bypass can be either internal or external depending on the site specific configuration. Surface bypass occurs with curb or grate type configurations where a secondary basin is installed just downstream of the MWS-Linear to intercept all flows above its treatment capacity. For pipe flows, an internal or external bypass pipe(s) or weir can be used at the proper elevation. This amount of fall ensures that the maximum wetland surface area is utilized in the MWS-Linear for maximum performance. The MWS-Linear can also accept runoff from upstream storage basins in a volume based configuration.

Depth to Groundwater Limitations

Since it is fully enclosed, the MWS-Linear does not have depth to groundwater limitations. For each installation, the manufacturer assess groundwater depth and calculates buoyancy assuming dry filtration media to assure that the system will be negatively buoyant.

Utility Requirements

The MWS-Linear system is a passive system that requires no power, and has a free-draining outfall to an appropriate water conveyance or storage system (e.g., wet pond, storm sewer, or underground infiltration).

Intended Application

The MWS-Linear is intended to be used for stormwater filtration in applications ranging from industrial and commercial to high and low density residential settings. Depending on the

land use, maintenance frequency may have to be adjusted accordingly. For instance, the pre-treatment chamber including the media cartridge pre-filter will likely have to be more frequently maintained when treating high ADT roadway versus residential street runoff.

Pretreatment Requirements

There are no pretreatment requirements for the MWS-Linear since the system includes a built-in multi-stage pre-treatment system. However, in applications where heavy sediment loading is anticipated from upstream basins connected to the MWS-Linear via pipe the use of catch basin filters or standard sumped catch basins can be helpful.

Current Installations

As of August 2013, there are 143 MWS-Linear installations nationwide. Appendix A provides the location, land use, and size of each of these installations. There is currently one MWS-Linear installed in the Pacific Northwest, with more than a dozen set for installation by the end of 2014.

Sizing Methodology

Laboratory testing of the MWS-Linear indicates high levels of pollutant removal performance at a loading rate of 100 inches an hour or 1.03 gallons per minute per square foot (gpm/sq ft) of surface area of the WetlandMedia inside the wetland chamber. The MWS-Linear offers adjustable pre-filter sizing based on influent solids loading. For moderate total suspended solids runoff concentrations of between 10 and 50 mg/L (typical of residential basins and moderate use parking lots), the pre-filter is sized at 3 gpm/sq ft of surface area. For total suspended solids loading greater than 50 mg/L (typical of commercial/industrial basins or high use parking lots), the pre-filter is sized at 2.1 gpm/sq ft of surface area. It is recommended that periodic monitoring during the first year of installation be conducted in order to determine the correct pre-filter configuration.

The MWS-Linear is available in over nine standard models, each model containing different size wetland chambers and pre-filter configurations. Since the MWS-Linear is a horizontal flow biofilter, its operation is similar to a radial cartridge. Influent stormwater fills the void area around the biofiltration bed (WetlandMedia) bed in the wetland chamber up to a specific operating level or height. The surface area of the biofiltration bed is calculated by adding all perimeter lengths by the operating height of the biofiltration bed. An orifice or flow control structure is housed downstream of the wetland chamber in the discharge chamber. The size of the orifice is calculated based upon a target-loading rate of 1.03 gpm/sq ft of surface area, with the maximum loading rate not to exceed the maximum flow rate for the three media cartridge pre-filters. The maximum water level before bypass is set to meet the required or desired operating level of the wetland chamber. The WetlandMedia has a hydraulic conductivity of greater than 12.75 gpm/sq (or 1,275 in/hr). This provides a safety factor of over 12 based on its orifice controlled design rate of 1.03 gpm/sq ft. The pre-filter media (BioMediaGREEN cubes) has a hydraulic conductivity of 5.95 gpm/sq ft (or 595 in/hr). This provides a safety factor of at least two based upon its design loading rate of between 2.1 and 3 gpm/sq ft.

For preliminary sizing purposes, a sizing table was developed that provides maximum contributing areas for each of the standard sizes of MWS-Linear for both western (Table 2) and eastern Washington (Table 3). In addition, the recommended number of pre-filter cartridges based on loading from the basin is provided in each table. The following sections describe the modeling used to generate the tables.

Western Washington

MWS-Linear systems designed for use in western Washington are sized using the Western Washington Hydrology Model, Version 2012 (WWHM2012), or another continuous hydrologic model approved by Ecology, to treat a minimum 91 percent of the annual stormwater volume. The remaining 9 percent of the annual stormwater volume bypasses the treatment system through either an external bypass pipe or internal weir wall. The design calculations for each size MWS-Linear system are determined at an approved hydraulic loading rate of 1.03 gpm/sq ft.

For preliminary flow-based sizing purposes, a sizing table was developed that provides maximum contributing areas for each of the standard sizes of MWS-Linear systems (Table 2). The table provides design flow rates for MWS-Linear systems with external bypasses, the design flow rates will be reduced by 29 and 18 percent for systems with internal piped or internal weir bypasses, respectively. The sizing table was generated based on a developed (“mitigated”) basin that consists of a flat parking area located in a region represented by the SeaTac rain gage with a precipitation-scaling factor of 1.0. The sizing table is to be used for planning level use only. The design engineer must use a continuous model with the site-specific drainage area and precipitation to confirm that the unit will treat the required volume. As part of the design process Modular Wetland System’s engineering department reviews the water quality requirements and confirms the MWS-Linear is sized correctly and according to the approved loading rate and projects treatment flow.

Eastern Washington

MWS-Linear systems designed for use in Eastern Washington are sized to treat the 6-month, 3-hour storm. For preliminary sizing purposes, a sizing table was developed that provides maximum contributing areas for each of the standard sizes of MWS-Linear systems in Region 3 - Spokane (Table 3). The table provides design flow rates for MWS-Linear systems with external bypasses, the design flow rates will be reduced by 29 and 18 percent for systems with internal piped or internal weir bypasses, respectively. The sizing table is to be used for planning level use only. The design engineer must use an approved single event model with the site-specific drainage area and precipitation to confirm that the unit will treat the required volume.

Expected Treatment Capabilities

The MWS-Linear is designed to remove gross solids, suspended solids, heavy metals, petroleum hydrocarbons, bacteria, and nutrients from stormwater. A combination of field and laboratory tests have been conducted on the MWS-Linear and the media cartridge pre-filter BioMediaGREEN. Specifically, in 2007 a scaled-down laboratory test was conducted to assess the performance of the MWS-Linear system; the same year, a separate laboratory test was

Table 2. MWS-Linear Sizing Table for Western Washington.

Available MWS Box Sizes (feet)	Total Wetland Media Surface Area (sf)	Water Quality Design Flow Rate Target (cfs)	Maximum Contributing Drainage Area (acres)	15-minute Offline Water Quality Flow Rate (cfs)	15-minute Offline Water Quality Flow Rate (gpm)	# of Pre-filter Cartridges: Moderate Influent Loading	# of Pre-filter Cartridges: High Influent Loading
4 x 4	22.8	0.052	0.567	0.052	23.3	3	4
3 x 6	34.2	0.078	0.850	0.078	35.0	4	6
4 x 8	50.3	0.115	1.253	0.115	51.6	6	8
4 x 13	62.6	0.144	1.569	0.144	64.6	7	10
4 x 15	76.2	0.175	1.907	0.175	78.5	8	12
4 x 17	89.8	0.206	2.245	0.206	92.5	10	14
4 x 19	103.4	0.237	2.582	0.237	106.4	11	16
4 x 21	117	0.268	2.920	0.268	120.3	13	18
8 x 12	151	0.346	3.770	0.346	155.3	16	23
8 x 16	201.3	0.462	5.033	0.462	207.4	21	30

Notes:

- Sizing table intended for planning level use. The design engineer must use WWHM2012 or approved equivalent and the site location mapping to calculate the appropriate facility size for each installation in western Washington.
- Sizing table meets the offline 15-minute water quality flow rate as specified in the Stormwater Management Manual for Western Washington (Ecology 2012).
- Sizing table based on WWHM2012 parking/flat basin (100 percent impervious) and SeaTac rain gage with precipitation factor of 1.0.
- Sizing based upon standard height unit with external bypass and an active wetland media height of 3.4 feet. Internal piped bypass will reduce the design flow rate by 29 percent while internal weir bypass (available on the 4x4, 4x8, 8x12, and 8x16 models) will reduce the design flow rate by 18 percent.
- Pre-filter sizing is adjustable based on influent loading. Moderate loading can be expected from residential areas and moderate use parking lots, heavy loading can be expected from commercial/industrial areas and high use parking lots.

Available MWS Box Sizes (feet)	Total Wetland Media Surface Area (sf)	Water Quality Design Flow Rate Target (cfs)	Maximum Contributing Drainage Area (acres)	6-month, 3-hour Flow Rate (cfs)	6-month, 3-hour Flow Rate (gpm)	# of Pre-filter Cartridges: Moderate Influent Loading	# of Pre-filter Cartridges: High Influent Loading
4 x 4	22.8	0.052	0.091	0.052	23.3	3	4
3 x 6	34.2	0.078	0.147	0.078	35.0	4	6
4 x 8	50.3	0.115	0.228	0.115	51.6	6	8
4 x 13	62.6	0.144	0.290	0.144	64.6	7	10
4 x 15	76.2	0.175	0.358	0.175	78.5	8	12
4 x 17	89.8	0.206	0.425	0.206	92.5	10	14
4 x 19	103.4	0.237	0.492	0.237	106.4	11	16
4 x 21	117	0.268	0.559	0.268	120.3	13	18
8 x 12	151	0.346	0.728	0.346	155.3	16	23
8 x 16	201.3	0.462	0.979	0.462	207.4	21	30

Notes:

1. Sizing table intended for planning level use. The design engineer must use an accepted single event model to calculate the appropriate facility size for each installation in eastern Washington.
2. Sizing table treats the 6-month, 3-hour storm as specified in the Stormwater Management Manual for Eastern Washington (Ecology 2004).
3. Sizing table based on a 100 percent impervious basin (CN = 98) and Region 3 - Spokane precipitation.
4. Sizing based upon standard height unit with external bypass and an active wetland media height of 3.4 feet. Internal piped bypass will reduce the design flow rate by 29 percent while internal weir bypass (available on the 4x4, 4x8, 8x12, and 8x16 models) will reduce the design flow rate by 18 percent.
5. Pre-filter sizing is adjustable based on influent loading. Moderate loading can be expected from residential areas and moderate use parking lots, heavy loading can be expected from commercial/industrial areas and high use parking lots.

conducted to assess the performance of the BioMediaGREEN alone. Subsequent to these tests, a full-scale field test of the MWS-Linear system was conducted in California to evaluate removal of several stormwater pollutants of concern, including total suspended solids, phosphorus, and total and dissolved metals. The results from these experiments indicated that the combination of the media cartridge pre-filter containing BioMediaGREEN and MWS-Linear WetlandMedia removed greater than 80 percent total suspended solids, 70 percent dissolved copper, 88 percent dissolved zinc, and 70 percent total phosphorus. Additional information about previous studies of the MWS-Linear and BioMediaGREEN can be found in the Conditional Use Level Designation (Herrera 2011a) for the MWS-Linear, which was filed with the Washington State Department of Ecology in May 2011.

Estimated Design Life

The non-consumable structural components of the MWS-Linear system are designed to last 25 years or more before needing maintenance or replacement of internal components. The concrete structure of the system has a user life of over 50 years. The manufacturer recommends that, on average, the pre-treatment chamber be maintained every 6 to 12 months. The manufacturer also recommends that the pre-filter media be replaced every 6 to 24 months depending on loading conditions and number of pre-filters installed. If pollutant loading is abnormally high, however (e.g., due to roadway sanding, construction runoff, or when installed at Industrial sites), the maintenance requirements of the pre-treatment chamber and media cartridge pre-filter will increase. In addition, if the system is inadvertently undersized for the basin it is expected that more frequent replacement of the pre-filter media will be required. Maintenance on the wetland chamber is not expected for many years, as the media cartridge pre-filter will prevent sediments and hydrocarbons from entering and clogging the WetlandMedia. Due to the high variation of loading conditions from site to site, it is recommended that first year inspections are done to assess the loading condition of the site on the MWS-Linear. Based upon this first year of observation, a site-specific maintenance frequency and pre-filter configuration can be established.

Installation

The MWS-Linear is a precast watertight concrete structure. The internal components are pre-assembled prior to delivery to the installation site. The system is delivered on a flatbed truck. The installer or contractor will need to provide a crane capable of off-loading the unit and placing it into the ground. Prior to delivery, the appropriate excavation should be completed, and the bottom 6 inches backfilled and leveled using the appropriate and recommended material compacted to 95 percent of maximum density.

Prior to installation, all inlets are blocked and wetland chamber covered to prevent construction sediment contamination from the site. Backfilling should be performed in a careful manner, bringing the appropriate fill material up in 6-inch lifts on all sides. Precast sections shall be set in a manner that will result in a watertight joint. In all instances, installation of the MWS-Linear shall conform to ASTM specification C891 *Standard Practice for Installation of Underground Precast Utility Structures*, unless directed otherwise in contract documents.

Operation and Maintenance Requirements

Every installed MWS-Linear unit is to be maintained by the Supplier, or a Supplier approved contractor for at least the first year. The cost of this service varies among outside service providers. The MWS-Linear is a multi-stage self-contained treatment train for stormwater treatment. Each stage is designed and intended to protect subsequent stages from clogging. Stages include screening, separation, cartridge media filtration, and biofiltration. The biofiltration stage can contain various types of vegetation or plantings. Annual inspection is required to evaluate plant health and trim excess vegetation. The maintenance procedures are described below.

- 1. Clean Catch Basin Filter** - On systems with surface inlet flow, screening is provided by a catch basin filter. The filter will contain coarse sediment, trash, and other floatables. Sediment capacity is reached at 2 cubic feet for the curb style inlet and 4 cubic feet for the drop or grated inlet configuration (varies with smaller and larger models). The filter removes gross solids, including litter, and sediment greater than 200 microns. The cleaning procedure is easily done by hand or with a small industrial vacuum device. This filter is located directly under the manhole cover or grate for easy access.
- 2. Clean Pre-Treatment Chamber** - separation occurs in the pre-treatment chamber's settling area located directly under the curb or grated inlet. This chamber has a capacity of approximately 21 cubic feet for trash, debris, and sediments for most model sizes (varies with smaller and larger models). The chamber targets total suspended solids and particulate metals and nutrients. Cleaning the settling area can be performed with a standard vacuum truck or hand held industrial shop vacuum. This chamber is located directly under the manhole or grate access cover for easy access into the chamber.
- 3. Replace Pre-Filter Cartridge Media (BioMediaGREEN™)** - Initial filtration is provided by a horizontal flow cartridge filter utilizing BioMediaGREEN media. Media life depends on local sediment loading conditions and can easily be replaced and disposed of without any equipment. The BioMediaGREEN media is held within the media cartridge pre-filters that are housed in the pre-treatment chamber. Entry into the pre-treatment chamber is required to replace the BioMediaGREEN media. The lid of the media cartridge pre-filter is removed by loosening two bolts. Once removed maintenance personnel have unimpeded access to each media cage housing the BioMediaGREEN which can be quickly removed by hand or with a vacuum truck. Once old BioMediaGREEN is removed new material, provided in pre-weighed bags, is dropped into the media cage housings. Once completed, the cartridge lid is replaced and bolts tightened on the lid of the media cartridge pre-filter.
- 4. Replace Drain Down Filter Media (BioMediaGREEN™)** - An optional drain down filter (not included in the test unit), similar in function to the media cartridge pre-filter is located in the discharge chamber. This filter allows any standing water from the pre-treatment chamber to drain from under the pervious pavers through the small filtration cartridge located in the discharge chamber. The drain down device addresses

any vector issues, by eliminating all standing water within the MWS-Linear. Replacement of media can be performed by hand.

5. **Trim Vegetation** - The MWS-Linear utilizes multiple plants in the wetland chamber to enhance pollutant removal. The vegetation will need to be maintained (trimmed) as needed and is done as part of regular site landscaping or system maintenance. Modular Wetland Systems, Inc. recommends that the plantings are never given any fertilizer to promote plant growth or health.
6. **Evaluate Flow Hydraulic Conductivity** - The system's flow characteristics can be assessed from the discharge chamber. This inspection for adequate flow capacity should be done during a rain event. By inspecting and viewing the discharge chamber, the flow out of the system can be easily observed or measure. If flow out of the orifice is too low, it could indicate media cartridge pre-filter fouling and maintenance may need to be provided to the BioMediaGREEN as described above.
7. **WetlandMedia Maintenance** - biofiltration is provided by an advanced horizontal flow vegetated wetland chamber. This biofilter contains a mix of sorptive media, known as WetlandMedia, which is designed to supports abundant plant and biological life. The life of this media can be up to 20 years when properly maintained. The peripheral void area surrounding the perimeter of the WetlandMedia can be accessed to remove any surface clogging. The vertical risers in the middle of the WetlandMedia can also be accessed and water injected to backwash the WetlandMedia. These features allow the wetland chamber to be fully maintained to ensure the WetlandMedia will not need to be replaced for many years. If full flow capacity cannot be restored by these steps, the WetlandMedia can be replaced.
8. **WetlandMedia Replacement** - Removal of spent WetlandMedia can be done with a shovel nose of any vacuum truck. Replacement of the WetlandMedia, although not anticipated for 20 years, is done by adding new WetlandMedia from a number of vendor supplied supersacs and added to fill the wetland chamber to recommended levels.

Reliability

The MWS-Linear is a robust water quality system designed to withstand a variety of conditions in the field. The media cartridge pre-filter containing BioMediaGREEN is designed to capture sediment and hydrocarbons and subsequently clog before the WetlandMedia in the biofiltration or wetland chamber. Once the pre-filter clogs, flow capacity decreases and the influent flows are routed around the wetland chamber through the external or internal bypass mechanism until the unit is maintained. The likelihood of this occurring is also significantly reduced by the design of the bypass. If an MWS-Linear begins to clog, it will go into bypass before flushing built up pollutants from the media(s) as bypass occurs around these mechanisms and not through their chambers. The pre-treatment chamber can also be fitted with an optional drain down system to prevent any standing water conditions in the chamber between storm events. This can be used in areas where vector control may be an issue. The current flow capacity of the MWS-Linear can easily be monitored by observing flow into the discharge chamber. Various instrumentation can be used to verify the flow rate through the system. If the system is

operating at less than 100 percent, treatment flow capacity maintenance procedures can be pre-formed in the pre-treatment chamber.

Modular Wetlands Systems, Inc. warrants that the materials used to manufacture its products will be able to withstand and remain durable to environmental conditions for a period of 5 years from the date of purchase. All other proprietary stormwater systems on the market today only offer a 1-year limited warranty.

Other Benefits and Challenges

Unlike many precast stormwater treatment devices, the MWS-Linear has a vegetative component that can add aesthetics to any streetscape. The plants in the wetland chamber perform an important filtration function while also adding an aesthetically pleasing element to what may otherwise be a barren urban context. Though the aesthetic aspects of the technology are in no way assessed herein, they are mentioned here as an element that may be of interest to municipalities serving the many landscape interests of their citizens.

SAMPLING PROCEDURES

This section describes the sampling procedures that were used to evaluate the performance of the MWS-Linear. It begins with a general overview of the monitoring design and describes the specific goals Ecology has established for the types of treatment that are being sought under the GULD. Separate sections then describe in more detail the site location, test system, monitoring schedule, and the specific procedures used to obtain the hydrologic and water quality data, respectively. Analytical methods, quality assurance and control measures, data management procedures, and data analysis procedures are also discussed.

Monitoring Design

To facilitate performance monitoring pursuant to the TAPE procedures, a 4- by 13-foot (ID) MWS-Linear unit (Model # MWS-L-4-13) was installed for testing purposes at the Portland Bureau of Maintenance Albina Maintenance Facility, which is located at North Mississippi and North Monroe Street in Portland, Oregon (Figure 1). This system is identified herein as the Albina Modular Wetland System (AMWS).

Automated equipment was installed in conjunction with the AMWS system to facilitate continuous monitoring of influent, effluent, and bypass flow volumes over a 14-month period extending from April 14, 2012, through May 31, 2013. In association with this hydrologic monitoring, automated samplers were also employed to collect flow-weighted composite samples of the influent and effluent during discrete storm events for subsequent water quality analyses.

Using the data obtained from the AMWS monitoring, removal efficiencies and effluent concentrations were characterized for targeted monitoring parameters. These data were subsequently compared to goals identified in the TAPE to support the issuance of a GULD for the MWS-Linear.

These treatment goals are described below for the three types of treatment that are under consideration for inclusion in the GULD:

1. **Basic Treatment** - 80 percent removal of total suspended solids for influent concentrations that are greater than 100 mg/L, but less than 200 mg/L. For influent concentrations greater than 200 mg/L, a higher treatment goal may be appropriate. For influent concentrations less than 100 mg/L, the facilities are intended to achieve an effluent goal of 20 mg/L total suspended solids.
2. **Phosphorus Treatment** - 50 percent removal of total phosphorus for influent concentrations ranging from 0.1 to 0.5 mg/L
3. **Dissolved Metals Treatment** - 30 percent removal of dissolved copper when influent concentrations range from 0.005 to 0.02 mg/L and 60 percent removal of dissolved zinc when influent concentrations range from 0.02 to 0.3 mg/L

Site Location

The AMWS system was installed at the Portland Bureau of Maintenance Albina Maintenance Facility, which is located at North Mississippi Avenue and North Monroe Street in Portland, Oregon (Figure 1). The Facility includes a parking lot for trucks and heavy equipment as well as outdoor storage of stockpiles of rock and dirt debris and miscellaneous snow removal equipment. Stormwater from the parking area for trucks and heavy equipment on the south side of the facility is collected in a series of catch basins along the western edge of the lot. Stormwater was conveyed from this system to Portland's municipal drainage system. The AMWS system received stormwater runoff from this parking area, and the treated effluent from the system was then discharged into the existing municipal drainage system before discharging via outfall to the Willamette River.

The drainage area for this parking lot and storage areas is approximately 0.45 acres (see site map in Figure 6 for delineation), and generally slopes from the east to the west with a grade of approximately 5.0 percent. The installation location for the MWS-Linear system within this drainage basin is designated "AMWS" in Figure 6.

Monitoring Schedule

Hydrologic and water quality monitoring were conducted at the AMWS test system over a 14-month period April 14, 2012, through March 31, 2013. During this monitoring period, 28 separate storm events were successfully sampled.

Test System Description

The AMWS test unit consists of a 4- by 13-foot ID vault with an 18.4-foot perimeter biofiltration bed (WetlandMedia), and had a piped inflow configuration (Figure 3). The Modular Wetland System Linear was constructed with an 8-inch smooth-walled PVC inlet pipe that enters the northeast wall of the pre-treatment chamber. Water exits the system through a 12-inch smooth-walled PVC outlet pipe located on the northeast wall of the discharge chamber.

In order to simplify monitoring, the AMWS was installed with an upstream external bypass weir (Figures 6 and 7). This configuration made it possible to segregate treated and bypassed flows for quantity and quality monitoring. The bypass weir was adjustable in order to maintain a specified driving head in the AMWS. The weir was adjusted to route the design flow rate of 41 gpm to the system before bypass occurred. The internal bypass piping was capped to prevent internal bypass flows from affecting estimates of treated effluent flow rates and chemistry.

Test System Sizing

The WWHM2012 was used to estimate water quality design flow rates for the 0.45-acre study basin. The WWHM2012 model was run for a moderate sloped basin (5 to 15 percent) and with a 15-minute time step. The resultant model run indicated that the water quality design flow

Figure 6.
 Site map of the MWS -
 Monitoring site (AMWS) at the
 Albina Maintenance Facility in
 Portland, Oregon.

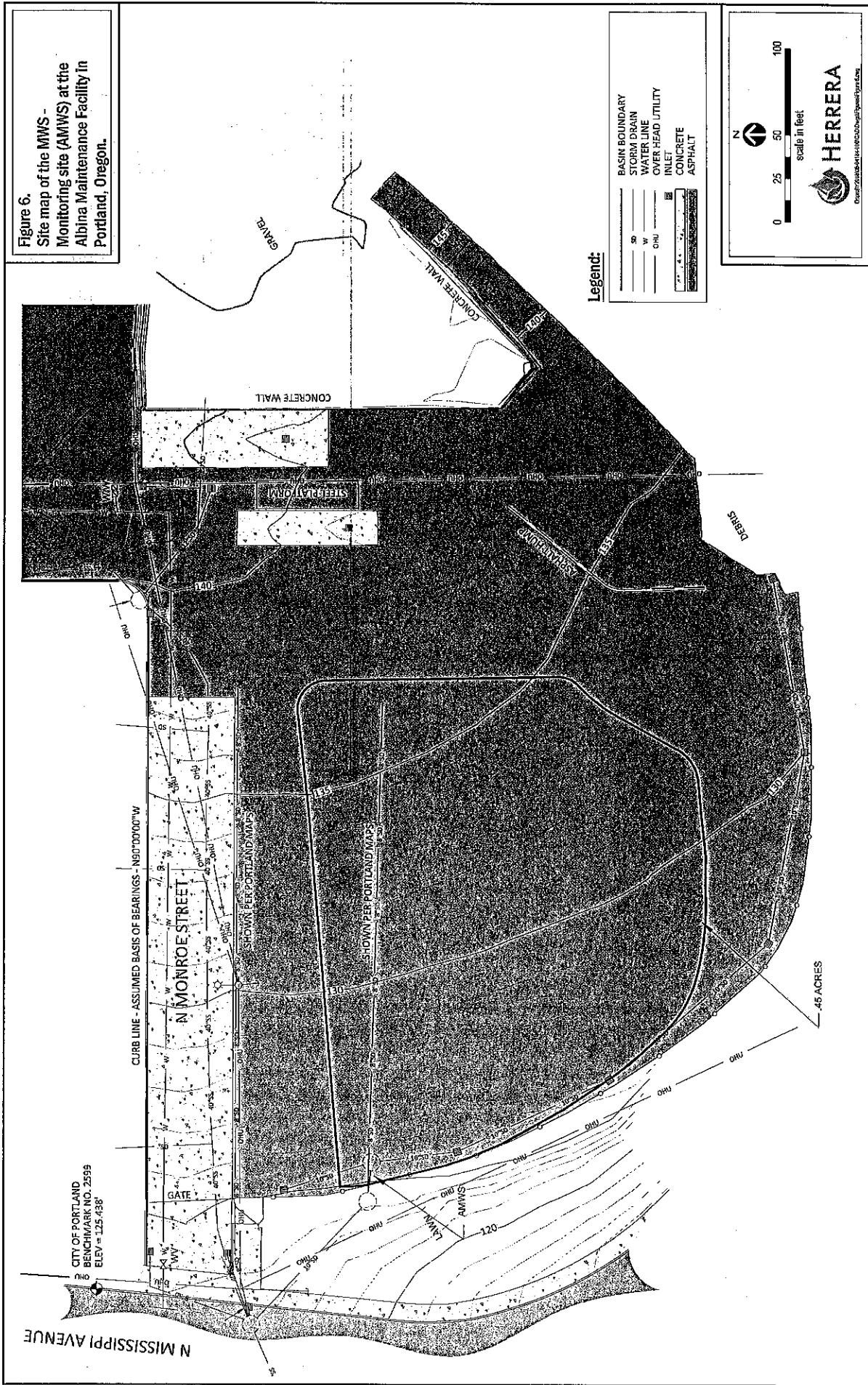

Copyright © 2004 Herrera Engineering & Construction, Inc.

Figure 7.
Plan view diagram of the MWS
monitoring site (AMWS).

- Legend**
- Pressure transducer and cable
 - Sampling and pH line cable
 - > Direction of flow
 - 3" conduit

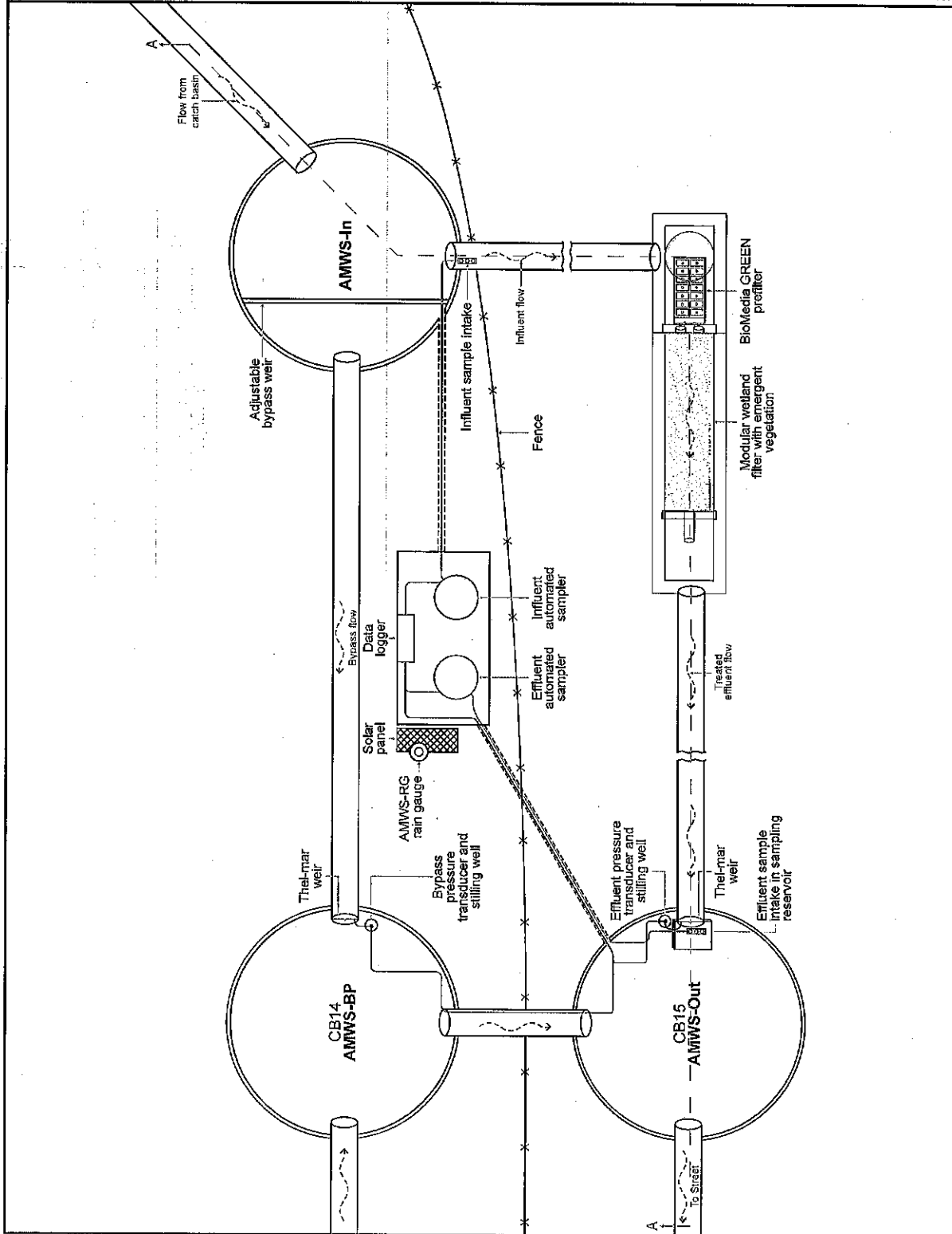
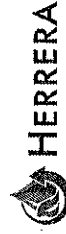

Figure 8.
Cross-section of the MWS
monitoring site (AMWS).

- Legend**
- Pressure transducer and cable
 - Sampling and pH line cable
 - Direction of flow
 - 3" conduit

Note: CB14 and associated bypass flow monitoring station not depicted in cross-section. See Figure 6.

Not to scale



03/20/2014 10:10 AM

Cross-section A-A

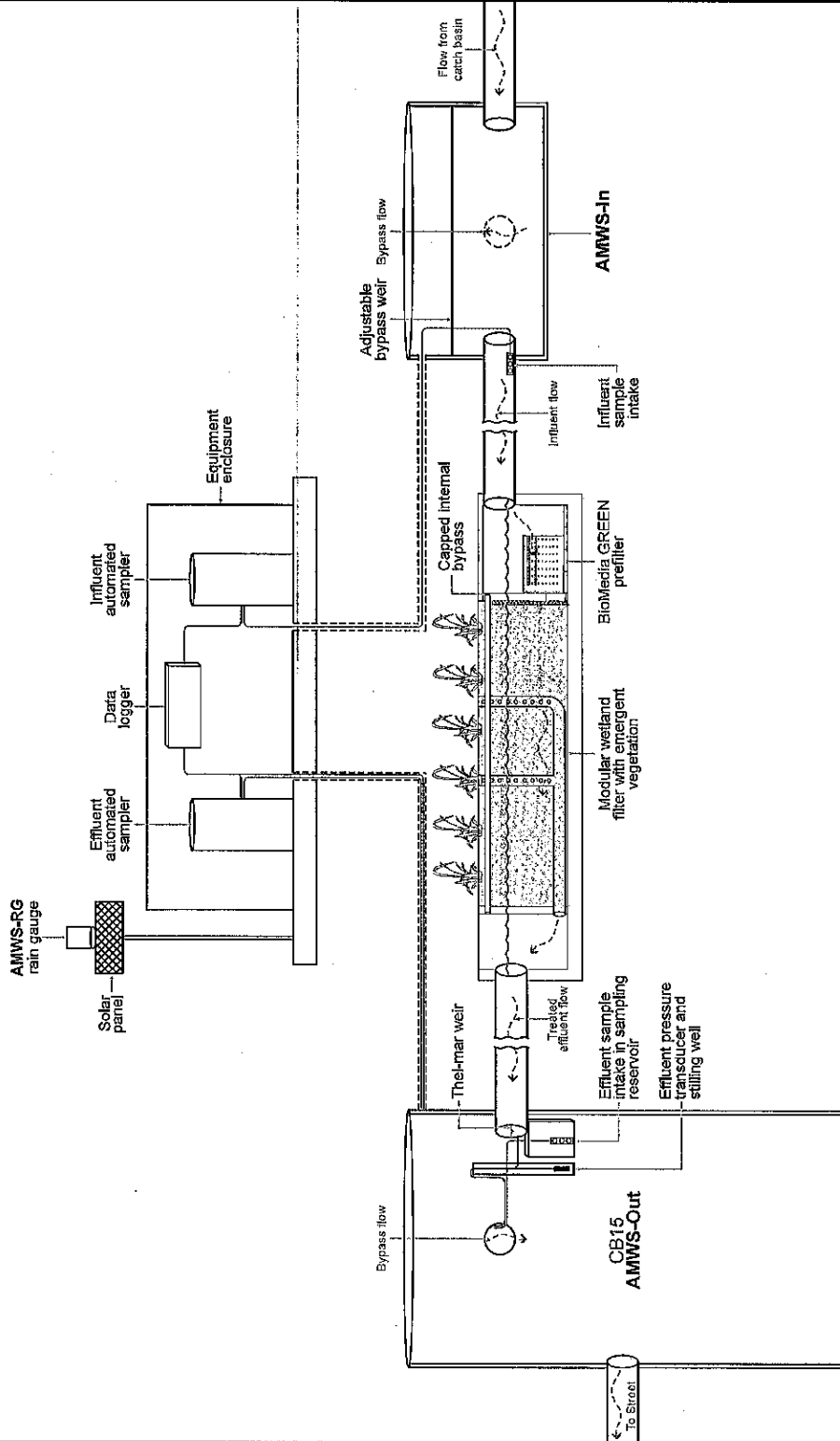

rate for the basin was 0.0676 cubic feet per second. However, preliminary flow monitoring indicated that a 1.5-inch storm generated a flow rate of 0.23 cubic feet per second (103 gallons per minute). This was an indication that additional flow was entering the basin. The basin is complex due to potential upslope contributions and the absence of a curb along the base of the basin. Due to the complexity of the drainage, it was exceedingly difficult to estimate the basin size for accurate WWHM3 modeling; consequently, the system was sized assuming a 0.45-acre drainage area. As mentioned above, this resulted in a design flow rate for the test system of 0.091 cfs (41 gpm). Subsequent analysis of the flow data after completion of the project indicated that, on average, a 1.54-inch storm produced a flow rate of 95 gpm. Based on hydrologic modeling, the 1.54-inch storm for the study region is equivalent to the 6-month storm. Standard sizing techniques dictate that in order to treat 91 percent of the annual runoff the system must be able to treat 100 percent of the 6-month storm. This is an indication that, even though the basin area was assumed larger than the mapped basin during the sizing calculations, the system was undersized for the basin.

Maintenance Schedule

Maintenance of the MWS-Linear consists of vactoring and power washing the pre-treatment chamber and replacing the BioMediaGREEN in the media cartridge pre-filters. The frequency of these maintenance activities is a function of solids loading from the site. The Albina Maintenance Facility was a challenging environment for stormwater filtration due to the high degree of fine sediment loading in the runoff (likely sourced from the debris piles in the yard and from mud and sediment from high levels of vehicle traffic in and out of the maintenance yard). The excessive fines fraction (Figure 9) blinded the BioMediaGREEN in the media cartridge pre-filter more quickly relative to what would be expected from suspended solids with a more typical particle size distribution (PSD) found in streets, parking lots and other land uses where installation of these systems generally occur. This site demonstrated a “worst case scenario” type condition that is in general found on dirty and unmaintained industrial sites. To adapt to this condition, various configurations of the BioMediaGREEN were tried to decrease maintenance frequency requirements on this site. These steps are described in this section.

Initially, standard solid BioMediaGREEN blocks were installed in the media filter pre-cartridge located in the pre-treatment chamber on April 12, 2012. After noting that the filter was blinding quicker than anticipated based on initial sediment load estimates (Figure 9), it was replaced on May 2, 2012 with a modified BioMediaGREEN with ribs to increase the filter surface area (Figure 9). These modified blocks were in place through a dry period during which one sample was collected, but again flow rates through the media diminished too rapidly and the BioMediaGREEN media was replaced again on August 8, 2012. To set a baseline, an perlite media (Figure 9) was installed for 2 months during which time two samples were collected. On October 26, 2012, a cubed BioMediaGREEN was installed (Figure 9), this media provided similar resistance to surface occlusion (blinding) as the perlite but with a more reactive surface. The cubed BioMediaGREEN lasted until January 27, 2013 (3 months), during which 13 samples were collected. It is anticipated that the cubed BioMediaGREEN would last 6 to 24 months depending on stormwater loading conditions. Per the current TAPE protocol, maintenance interval will be determined on a site-by-site basis after issuance of a GULD. In addition, the manufacturer now recommends using additional

pre-filter cartridges for sites with high solids loading (see Tables 2 and 3). Analysis of the potential effect of the various pre-filters on the final data set is presented below in the *Water Quality Results* section.

During the entire duration of the field testing the flow rate through the wetland chamber and its WetlandMedia was unaffected. The last few storms during May of 2013 had some of the highest recorded treatment flow rates proving that the pre-treatment chamber and its pre-settling and pre-filters prevented the migration of fine sediments and hydrocarbons from reaching the wetland chamber and affecting its flow rate capacity directly. Based upon these findings it is estimated that maintenance on the wetland chamber will not be required for several years.

Hydrologic Monitoring Procedures

Generalized schematics of the equipment that was installed in association with the AMWS test system are provided in Figures 6 and 7. The equipment installation was completed on April 22, 2011. Continuous hydrologic monitoring was performed in conjunction with the AMWS test system at four separate monitoring stations: AMWS-BP, AMWS-OUT, AMWS-RG, and AMWS-IN (Figures 6 and 7). AMWS-BP was a bypass flow monitoring station, AMWS-OUT was an effluent flow monitoring station located at the outlet that was used to characterize influent flows since there are no water losses through the system, and AMWS-RG was a precipitation monitoring station. AMWS-IN was only used for sample collection and no hydrologic monitoring was conducted at the station. These hydrologic monitoring stations are discussed in separate subsections below, followed by a summary of the maintenance procedures performed on the monitoring equipment. These monitoring procedures are also described in greater detail within the quality assurance project plan (QAPP) that were prepared for this study (Herrera 2011b) (Appendix B).

Hydrologic monitoring instruments at each of the stations discussed below were all interfaced with a Campbell Scientific CR1000 datalogger, which served to record data, run simple algorithms based on those data, and control the automated sampling equipment. The datalogger was programmed to scan every 10 seconds and record average readings on a 5-minute time step. The datalogger was interfaced with an Airlink Raven XTV digital cellular modem (Appendix B). This communication system was configured to automatically download data on a 5-minute basis and send text message alarms to field technicians and project managers. Power to the system was supplied using a 12-volt sealed, rechargeable battery that was charged using an 80-watt solar panel installed at the site.

The datalogger, battery, digital cell phone link, and automated samplers were housed in a Knaack box model 69 enclosure (Appendix B). Conduit was installed to convey pressure transducer cabling and autosampler suction lines from the base of the enclosure to each station.

Bypass Flow Monitoring (AMWS-BP)

In order to simplify monitoring, the AMWS was installed with an upstream external bypass (Figures 6 and 7). This configuration made it possible to segregate treated and bypassed flows for quantity and quality monitoring. The upstream bypass weir was adjustable in order to



Highly turbid inflow

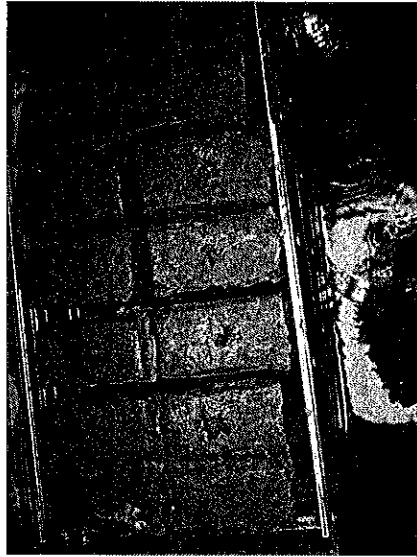

BioMediaGREEN blocks coated with fines

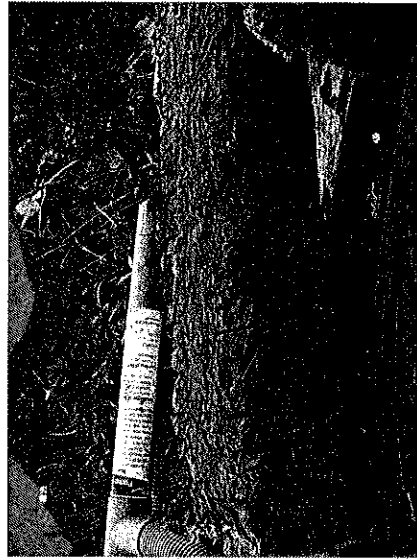

Ribbed BioMediaGREEN blocks coated with fines

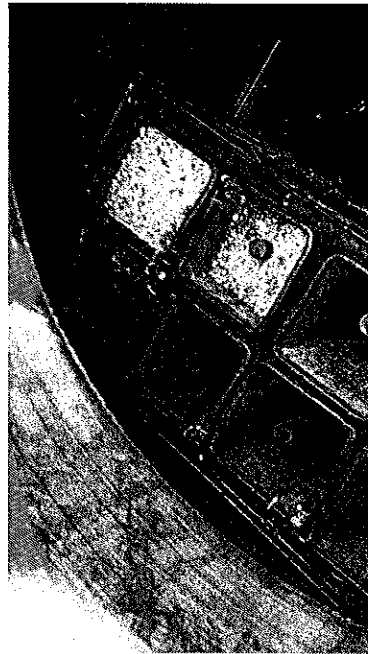

Installation of temporary perite prefilter with new cartridge design



Cubed BioMediaGREEN ready for installation



High sediment loading in drainage basin

Figure 9. Photos of Sediment Loading and Pre-filters Used at the AMWS Monitoring Site.

maintain required driving head in the MWS-Linear. The weir was adjusted to route the design flow rate of 0.091 cfs (41 gpm) to the system before bypass occurred. The internal bypass piping was capped to prevent internal bypass flows from affecting estimates of treated effluent flow rates and chemistry. Engineering design plans for the AMWS system are provided in Appendix C.

Water that passed over the diversion weir was routed through a 10-inch pipe to CB-14 (Figure 7). A 10-inch Thel-Mar weir was installed at the end of this pipe and a hole was drilled through the face of the weir for connecting a section of reinforced 3/8-inch ID polyethylene tubing. The other end of the tubing was connected to a stilling well that was constructed from 3-inch diameter PVC pipe. An Instrumentation Northwest PS9805 submersible pressure transducer (0 to 2.5 psi) was installed in the stilling well to measure water levels behind the Thel-Mar weir. The pressure transducer was interfaced with the Campbell Scientific CR1000 datalogger described above. When bypass occurred, the datalogger converted bypass weir water level readings to estimates of discharge based on standard hydraulic equations (Walkowiak 2006).

Influent/Effluent Flow Monitoring Station (AMWS-OUT)

To facilitate continuous monitoring of influent and effluent flow rates, a monitoring station, designated AMWS-OUT, was established at the end of the 12-inch outlet pipe (Figures 6 and 7). It was assumed that, given the small size and associated low water residence time for the AMWS, the effluent flow would be essentially equivalent to influent. A 12-inch Thel-Mar was installed at the end of the outlet pipe in CB15 and a hole was drilled through the face of the weir for connecting a section of reinforced 3/8-inch ID polyethylene tubing. The other end of the tubing was connected to a stilling well that was constructed from 3-inch diameter PVC pipe. An Instrumentation Northwest PS9805 submersible pressure transducer (0 to 2.5 psi) was installed in the stilling well to measure water levels behind the Thel-Mar weir.

The AMWS-OUT pressure transducer was interfaced with the same Campbell Scientific CR1000 datalogger described above. The datalogger converted water level readings in the stilling well (which were equivalent water levels behind the Thel-Mar weir) to estimates of discharge based on standard hydraulic equations (Walkowiak 2006).

Precipitation Monitoring Station (AMWS-RG)

In addition to the two pressure transducer stations, a third hydrologic monitoring station, designated AMWS-RG, was installed adjacent to the equipment enclosure (Figures 6 and 7) to facilitate continuous monitoring of precipitation depths. The station was equipped with a Hydrological Services TB4-L60 rain gauge (Appendix B) that was mounted on an 8-foot steel pole and interfaced with the same Campbell Scientific CR1000 datalogger described above.

Monitoring Equipment Maintenance and Calibration

Maintenance and calibration of the rain gauge and flow monitoring equipment was conducted on a routine basis during pre- and post-storm checks. Instrument maintenance and calibration activities were documented on standardized field forms. Rain gauge and level calibration data can be found in the hydrologic data quality assurance memorandum in Appendix D. In

addition, on February 14, 2013, a dynamic flow test was conducted using known flow rates from a nearby fire hydrant. The hydrant flows were used to calibrate the Thel-Mar weir equations at AMWS-OUT and AMWS-BP. Results from the dynamic flow testing are presented in Appendix D. The adjusted rating curves which resulted from this testing were applied to the entire dataset prior to final analysis.

Water Quality Monitoring Procedures

To evaluate the water quality treatment performance of the AMWS test system, water quality sampling was conducted at the influent (AMWS-IN) and effluent (AMWS-OUT) stations (Figures 6 and 7) during 28 discrete storm events over the period from April 2012 through May 2013. A general description of the procedures used for this monitoring is provided herein. A more detailed description of these procedures can also be obtained from the QAPP that was prepared for this study (Herrera 2011b). To facilitate water quality sampling for this study, Isco 6712 portable automated samplers were installed in association with the AMWS-IN and AMWS-OUT stations. The intake strainer for the automated sampler at the AMWS-IN station was positioned in the outlet pipe of the bypass structure (Figures 6 and 7); the intake strainer for the automated sampler at the AMWS-OUT station was located in a sampling tray located below the invert of the outlet pipe in CB15. In each case, the sampler intakes were positioned to ensure the homogeneity and representativeness of the collected samples. Specifically, sampler intakes were installed to make sure adequate depth was available for sampling and to avoid capture of litter, debris, and other gross solids that might be present. The sampler suction lines consisted of Teflon tubing with a 3/8-inch inner diameter.

The following conditions served as guidelines in defining the acceptability of specific storm events for sampling:

- **Target storm depth:** A minimum of 0.15 inches of precipitation over a 24-hour period
- **Antecedent conditions:** A period of at least 6 hours preceding the event with less than 0.04 inches of precipitation
- **End of storm:** A continuous period of at least 6 hours after the event with less than 0.04 inches of precipitation

Antecedent conditions and storm predictions were monitored via the Internet, and a determination was made as to whether to target an approaching storm. Once a storm was targeted, field staff visited each station to verify that the equipment was operational and to start the sampling program. A clean 20-liter polyethylene carboy and crushed ice were also placed in the sampling equipment at this time. The speed and intensity of incoming storm events were tracked using Internet-accessible Doppler radar images. Actual rainfall totals during sampled storm events were quantified based on data from the rain gauge installed at the site. During the storm event sampling, the datalogger was programmed to enable the sampling routine in response to a predefined increase in water level (stage) at AMWS-OUT. The automated samplers were then programmed to collect 220-milliliter sample aliquots at preset flow increments. Based on the expected size of the storm, the flow increment was

adjusted to ensure that the following criteria for acceptable composite samples were met at each station:

- A minimum of **10 aliquots**
- Sampling was targeted to capture **at least 75 percent** of the hydrograph
- Due to sample holding time considerations, the maximum duration of automated sample collection was **36 hours**.

After each targeted storm event, field personnel returned to each station, made visual and operational checks of the sampling equipment, and determined the total number of aliquots composited. Pursuant to the sampling goals identified above, the minimum number of composites that constituted an acceptable sample was 10. If the sample was determined to be acceptable, the carboy was immediately capped, removed from the automated sampler, and kept below 6°C using ice during transport to the laboratory. All samples were delivered to the laboratory with appropriate chain-of-custody documentation. Collected flow-weighted composite samples were then analyzed for the following parameters:

- Total suspended solids (TSS)
- Particle size distribution (PSD)
- Total phosphorus (TP)
- Orthophosphorus
- Total and dissolved copper
- Total and dissolved zinc
- pH
- Hardness

Additional parameters were measured, but this report only addresses those parameters that are pertinent to the basic, phosphorus, and enhanced treatment GULD.

Sediment Monitoring Procedures

In addition to water sampling, TAPE guidance calls for the assessment of sediment accumulation and sediment particle size distribution within the monitored treatment technology. However, under normal operating conditions, sediment will settle in the pre-treatment chamber of MWS-Linear system and the media cartridge pre-filter. Each pool of sediment will have a different volume and particle size distribution. To assess the particle size distribution and sediment volume within the each of these areas would be exceedingly difficult. This process would also likely be prohibitively expensive and, due to the difficulty of differentiating between media and accumulated sediment, would result in an inaccurate assessment of accumulated sediment volume and particle size distribution. Due to these considerations, field technicians only recorded sediment depth within the pre-treatment chamber. Particle size distribution of these accumulated sediments was not conducted

because it would not provide an assessment of total system treatment; rather, it would only provide an assessment of the setting unit-process aspect of the pre-treatment.

Analytical Methods

Analytical methods for this project are summarized in Table 4. Test America in Portland, Oregon, was the initial laboratory used for this project. However, due to performance issues with the lab that did not affect data quality, ALS, Inc. in Kelso, Washington, was used for the final 17 collected composite samples. Both laboratories are certified by Ecology, and participate in audits and inter-laboratory studies by Ecology and EPA. These performance and system audits have verified the adequacy of the laboratory's standard operating procedures, which include preventive maintenance and data reduction procedures. Chemoptix Laboratories in West Linn, Oregon was initially used for PSD analysis; when the lab switch occurred, PSD was analyzed at Analytical Resources, Inc. in Tukwila, Washington.

Quality Assurance and Control Measures

Field and laboratory quality control procedures used for the MWS-Linear evaluation are discussed in the following sections. Quality assurance memorandums discussing hydrologic and water quality data can be found in Appendices C and D, respectively.

Field Quality Assurance/Quality Control

This section summarizes the quality assurance/quality control (QA/QC) procedures that were implemented by field personnel to evaluate sample contamination and sampling precision.

Field Blanks

Automated sampler tubing was cleaned before the collection of each aliquot using an automated double rinse cycle. In addition, deionized water was back flushed through the sample tubing before each monitored event. Field blanks were collected on November 10, 2011, prior to the first sampled storm event at both monitoring locations. A second set of field blanks was collected on March 1, 2012, after a few storm events had been sampled. The field blanks were collected by pumping reagent-grade water through the intake tubing into a pre-cleaned sample container. The volume of reagent grade water pumped through the sampler for the field blank was similar to the volume of water collected during a typical storm event.

Field Duplicate Samples

Field duplicates were collected for approximately 10 percent of the samples. The station where the field duplicates were collected was chosen at random in advance of the storm event. To collect the field duplicates, a separate automated sampler (i.e., ISCO 6712 Full Size Portable Sampler) with a 9.4-liter bottle was set up at the selected monitoring station with a separate set of sample tubing. The automated sampler was wired to the Campbell Scientific datalogger, and each time the flow trigger occurred, both samplers would draw a stormwater sample at the same time. Sample tubing was staggered, so the two pumps would not affect sample volume if sufficient flow were present. The resultant data from these samples was

Table 4. Methods and Detection Limits for Water Quality Analyses.

Parameter	Analytical Method	Method Number ^a	Field Sample Container	Pre-Filtration Holding Time	Total Holding Time ^b	Field Preservation	Laboratory Preservation	Reporting Limit/Resolution	Units
Total suspended solids	Gravimetric ^c	SM 2540D	20 L HDPE bottle	7 days	7 days	Maintain ≤ 6°C	Maintain ≤ 4°C	1.0	mg/L
Total phosphorus	Automated ascorbic acid	EPA 365.3		NA	28 days		Maintain ≤ 4°C, H ₂ SO ₄ to pH < 2	0.002	mg/L
Orthophosphorus	Automated ascorbic acid	EPA 365.3		24 hours ^d	48 hours		Maintain ≤ 4°C, H ₂ SO ₄ to pH < 2	0.001	mg P/L
Hardness	Titration	SM 2340B		28 days	28 days		Maintain ≤ 4°C, HNO ₃ to pH < 2	0.1	mg/L as CaCO ₃
pH	Potentiometric	SM 4500-H ⁺		24 hours ^d	24 hours		Maintain ≤ 4°C	0.01	std. units
Particle Size Distribution	Sieve and filter	TAPE App. F		7 days	7 days		Maintain ≤ 4°C	NA	microns
Copper, dissolved	ICP-MS	EPA 200.8		18 hours ^b	6 months		Maintain ≤ 4°C, HNO ₃ to pH < 2 after filtration ^g	0.002	mg/L
Copper, total				NA			Maintain ≤ 4°C, HNO ₃ to pH < 2	0.002	
Zinc, dissolved	ICP-MS	EPA 200.8		18 hours ^d	6 months		Maintain ≤ 4°C, HNO ₃ to pH < 2 after filtration ^g	0.01	mg/L
Zinc, total				NA			Maintain ≤ 4°C, HNO ₃ to pH < 2	0.01	

^a SM method numbers are from APHA et al. (1998); EPA method numbers are from US EPA (1983, 1984). The 18th edition of *Standard Methods for the Examination of Water and Wastewater* (APHA et al. 1992) is the current legally adopted version in the *Code of Federal Regulations*.

^b Holding time specified in US EPA guidance (US EPA 1983, 1984) or referenced in APHA et al. (1992) for equivalent method.

^c A G4 glass fiber filter will be used for the total suspended solids filtration.

^d EPA requires filtering for orthophosphorus and dissolved metals and measurement of pH within 15 minutes of the collection of the last aliquot. This goal is exceedingly difficult to meet when conducting flow-weighted sampling. A more practical proxy goal for this study is 24 hours.

C = Celsius.

mg/L = milligrams per liter.

HDPE = High-Density Polyethylene

NA = not applicable.

used to assess variation in the analytical results that is attributable to environmental (natural) and analytical variability.

Flow Measurements

The accuracy and precision of the automated flow measurement equipment were tested prior to the first monitoring round and periodically throughout the project. Level calibration data can be found in the hydrologic data quality assurance memorandum in Appendix D.

Laboratory Quality Control

Accuracy of the laboratory analyses was verified with blank analyses, duplicate analyses, laboratory control spikes, and matrix spikes in accordance with the analytical methods employed. Test America, Inc. and ALS, Inc. were responsible for conducting internal quality control and quality assurance measures in accordance with their own quality assurance plans.

Water quality results were first reviewed at the laboratory for errors or omissions, and to verify compliance with acceptance criteria. The laboratories also validated the results by examining the completeness of the data package to determine whether method procedures and laboratory quality assurance procedures were followed. The review, verification, and validation by the laboratory were documented in a case narrative that accompanied the analytical results.

Data were also reviewed and validated by Herrera within 7 days of receiving the results from the laboratory. This review was performed to ensure that all data were consistent, correct, and complete, and that all required quality control information was provided. Specific quality control elements for the data were also examined to determine if the method quality objectives (MQOs) for the project were met. Results from these data validation reviews were summarized in quality assurance worksheets prepared for each sample batch. Values associated with minor quality control problems were considered estimates and assigned *J* qualifiers. Values associated with major quality control problems were rejected and qualified with an *R*. Estimated values were used for evaluation purposes, but rejected values were not used.

Data Management Procedures

Flow and precipitation data was uploaded after each storm event remotely using telemetry systems (i.e., Raven cell link modem) and transferred to a database (LoggerNet and Aquarius software) for all subsequent data management tasks.

Test America, Inc. and ALS, Inc. reported the analytical results within 30 days of receipt of the samples. The laboratories provided sample and quality control data in standardized reports suitable for evaluating project data. These reports included all quality control results associated with the data, a case narrative summarizing any problems encountered in the analyses, corrective actions taken, any changes to the referenced method, and an explanation of data qualifiers. Laboratory data was subsequently entered into a Microsoft Access database for all subsequent data management and archiving tasks.

Data Management Quality Control

An independent review was performed to ensure that the data were entered into the database without error. Specifically, all of the sample values in the database were crosschecked to confirm they were consistent with the laboratory reports.

Data Analysis Procedures

Analysis procedures that were used for the hydrologic and water quality data are summarized below.

Hydrologic Data Analysis Procedures

The compiled hydrologic data were analyzed to obtain the following information for each sampled and unsampled storm during the monitoring study:

- Precipitation depth
- Average precipitation intensity
- Peak precipitation intensity
- Antecedent dry period
- Precipitation duration
- Bypass flow duration
- Effluent flow duration
- Bypass peak discharge rate
- Effluent peak discharge rate
- Bypass discharge volume
- Effluent discharge volume

A subset of this information was examined in conjunction with sample collection data to determine if individual storm events met the TAPE guidelines for valid storm events. Bypass frequency data was also used to assess when BioMediaGREEN media required replacement.

Water Quality Data Analysis Procedures

Data analyses were performed to evaluate the water quality treatment performance of the test system. The specific procedures that were used in these analyses are as follows:

- Statistical comparison of influent and effluent concentrations
- Calculation of pollutant removal efficiency using bootstrap analysis
- Calculation of pollutant removal efficiency as a function of flow

Each of these procedures is described in more detail in the following subsections.

Statistical Comparisons of Influent and Effluent Concentrations

Pollutant concentrations were compared for paired influent and effluent across all storm events using a 1-tailed Wilcoxon signed-rank test (Helsel and Hirsch 2002). Using a paired test, differences in the influent and effluent concentrations could be more efficiently assessed, because the noise (or variance) associated with monitoring over a range of storm sizes can be factored out of the statistical analyses. A 1-tailed test was used to evaluate the specific hypothesis that effluent pollutant concentrations were significantly lower than those in the influent were. In all cases, the statistical significance was evaluated at an alpha level (α) of 0.05.

Calculation of the Pollutant Removal Efficiency using Bootstrap Analysis

The removal (in percent) in pollutant concentration during each individual storm (ΔC) was calculated as:

$$\Delta C = 100 \times \frac{(C_{in} - C_{eff})}{C_{in}}$$

Where: C_{in} = Flow-weighted influent pollutant concentration

C_{eff} = Flow-weighted effluent pollutant concentration

After the percent removal for each qualifying event was calculated, the mean percent removal values and 95 percent confidence interval about the mean were estimated using a bootstrapping approach (Davison and Hinkley 1997). Bootstrapping offers a distribution-free method for estimates of confidence intervals of a measure of central tendency. The generality of bootstrapped confidence intervals means they are well suited to non-normally distributed data or datasets not numerous enough for a powerful test of normality.

To perform the bootstrapping analysis, the percent removal values for each valid event were sampled randomly with replacement until a new synthetic percent removal dataset of equivalent size was generated. The median percent removal was then calculated on the synthetic dataset and the process was repeated. Repetition generates a distribution of possible values for the mean. Quantiles of this distribution are confidence intervals of the statistic. For example, in the analysis the mean was replicated 10,001 times; after sorting the replications, the 250th and 9,750th elements constituted the 95 percent confidence interval of the median, while the reported mean was the 5,000th ranked value.

The results from this test were used to determine if the mean percent removal was significantly different from percent removal thresholds presented in TAPE (e.g., 80 percent total suspended solids removal).

Calculation of Pollutant Removal Efficiency as a Function of Flow

To determine pollutant removal performance as a function of flow rate the sampled flow rate must first be calculated. Specifically, for composite samples the instantaneous flow rates associated with each aliquot were averaged over the sampled event to generate an average sampled flow rate. This value was then compared with the percent pollutant removal for the event. This process was repeated for each sampled event, the results were plotted on a percent removal versus sampled flow rate graph, and a regression analysis conducted to determine if system performance varied as a function of influent flow rate.

DATA SUMMARIES AND ANALYSIS

This section summarizes data collected during the 2012-2013 monitoring period. The presentation of these data is organized under separate subsections for the hydrologic and water quality monitoring results, respectively. A memorandum discussing the quality of the hydrologic data is presented in Appendix D, while Appendix E presents a quality assessment of the water quality data.

Hydrologic Data

To provide some context for interpreting the data, this section begins with a comparison of rainfall totals measured during the monitoring period relative to historical data. Appendix D summarizes results from the quality assurance review that was performed on hydrologic data prior to their analysis herein.

Historical Rainfall Data Comparison

To provide some context for interpreting the hydrologic performance of the MWS-Linear, an analysis was performed on rainfall data collected at the National Weather Service (NWS) rain gauge at Portland Airport (PDX) to determine if rainfall totals from the monitoring period (i.e., April 1, 2012, through May 31, 2013) were anomalous. The NWS rain gauge is located at Portland International Airport, approximately 4.9 miles northeast of the AMWS rain gauge. The analysis specifically involved a comparison of rainfall totals measured at the PDX rain gauge over the monitoring period to averaged totals for the same gauge from the past 73 years. These data are summarized in Table 5 along with data from the rain gauge associated with the AMWS monitoring site.

Results from this analysis showed the average annual rainfall total at the Portland Airport rain gauge from 1940 through 2013 was 42.9 inches. In comparison, the rainfall total at the same rain gauge over the monitoring period was 41.3 inches. This value is within the normal range of rainfall (i.e., 25th to 75th percentile) for the Portland Airport rain gauge based on the 73-year rainfall record; thus, the rainfall total during the monitoring year is generally representative of rainfall during an average year.

Table 5 also indicates that precipitation measured at the Albina Maintenance Facility Bureau of Environmental Services gauge were similar to rainfall measurements at PDX during the monitoring period. However, rain data collected with the project rain gauge at AMWS-RG were approximately 17 percent greater than at the Albina Maintenance Facility Bureau of Environmental Services or PDX gauge. This discrepancy is discussed further in the hydrologic quality assurance assessment (Appendix D).

Month	AMWS Rainfall Data (2012-2013) ^a	Portland Albina Maintenance Facility BES Gauge Rainfall Data (2012-2013) ^b	Portland Airport NWS Station PDX Rainfall Data (2012-2013)	Portland Airport NWS Station PDX Rainfall Data (1940-2013) ^c
April	4.09	3.18	3.25	2.73
May	3.83	3.11	3.37	2.47
June	3.45	2.98	4.10	1.70
July	0.39	0.29	0.21	0.65
August	0.00	0.01	0.00	0.67
September	0.02	0.01	0.04	1.47
October	6.41	5.61	6.14	3.00
November	9.35	8.32	8.23	5.63
December	9.6	8.54	7.56	9.63
January	3.09	2.83	3.49	4.88
February	3.22	1.48	1.26	3.66
March	2.19	2.09	1.46	3.68
April	2.67	2.38	2.19	2.73
May	5.19	4.21	4.57	3.35
Total	53.5	45.04	45.87	46.25

AMWS: Albina Modular Wetland System

BES: Bureau of Environmental Services

^a Source: AMWS RG precipitation monitoring station for the AMWS

^b Source: Portland Bureau of Environmental Services

^c Source: Portland Airport rain gauge (<http://www.wrh.noaa.gov/pgr/pdxclimate/index.php>). Based on average monthly and annual precipitation totals measured over the period from 1940 to 2013.

Water Budget

The water budget for the AMWS test system was analyzed to determine bypass frequency and volume (Table 6). WWHM modeling indicated that with the estimated basin area of 0.45 acres, the water quality design flow rate is 0.091 cfs or 41 gpm.

Separate analyses of hydrologic data were performed to meet the following objectives:

- Determine whether treatment goals for the test system were met based on the volume treated and bypassed
- Determine whether bypass frequency and volume varied as a function of storm rainfall depth, storm rainfall intensity, influent flow volume, and sampling date
- Determine site specific maintenance frequency by examining bypass over the course of the study

The data used in these analyses are presented in their entirety in Appendix F.

Table 6. Summary Statistics for Storms That Produced Bypass Flow at the AMWS Test System from April 1, 2012, Through May 31, 2013.

Storm Start Date & Time	Storm Depth (Inches)	Peak Storm Intensity (in/hr)	Total Volume (gpm)	Bypass Volume (gallons)	% of Total Volume Bypassed	Peak Treated Flow Rate during Bypass (gpm)
New Pre-Filter Installed 4/12/2012 (Solid BioMediaGREEN)						
4/17/2012 21:20	0.31	0.03	1168	407	26	24.1
4/19/2012 8:30	0.68	0.02	1499	991	40	12.0
4/29/2012 22:50	0.33	0.01	1786	112	6	19.5
6/1/2012 13:10	0.15	0.03	902	98	10	13.4
New Pre-Filter Installed 5/2/2012 (Ribbed BioMediaGREEN)						
5/4/2012 5:10	0.41	0.08	2133	4179	66	45.3
5/22/2012 8:35	0.37	0.03	3689	487	12	38.5
5/24/2012 19:10	0.15	0.03	1330	165	11	29.6
5/25/2012 19:35	0.21	0.02	1249	254	17	26.7
6/4/2012 20:20	0.63	0.04	2836	1885	40	8.7
6/7/2012 3:10	0.52	0.02	1802	1286	42	5.7
6/8/2012 7:10	0.57	0.1	839	2806	77	3.9
8/22/2012 18:40	0.5	0.04	1428	261	16	10.1
6/24/2012 3:45	0.23	0.02	388	198	33	2.4
New Pre-Filter Installed 8/28/2012 (Perlite)						
10/14/2012 19:15	0.65	0.05	6309	190	3	41.8
10/15/2012 12:30	0.58	0.06	5210	2370	31	41.8
10/19/2012 13:00	0.39	0.06	3286	33	1	40.6
New Pre-Filter Installed 10/29/2012 (Cubed BioMediaGREEN)						
10/27/2012 6:50	0.61	0.03	4834	272	5	46.7
10/28/2012 8:15	1.04	0.03	10302	399	4	48.0
10/29/2012 22:45	0.65	0.05	5786	572	9	48.0
11/1/2012 13:20	1.41	0.02	12382	84	1	42.3
11/17/2012 3:05	0.72	0.04	5820	267	4	40.6
11/18/2012 16:10	2.27	0.08	24874	8491	25	37.0
11/20/2012 3:50	0.58	0.1	5170	2710	34	30.0
11/20/2012 19:25	0.28	0.02	2251	789	26	26.1
11/21/2012 9:15	0.19	0.03	1519	154	9	23.4
11/23/2012 8:25	1.61	0.03	16628	6982	30	23.4
11/29/2012 8:15	0.57	0.03	4597	762	14	20.6
11/30/2012 17:35	0.7	0.04	5181	6085	54	21.0
12/1/2012 14:10	0.66	0.03	8123	2694	25	16.3
12/3/2012 22:30	0.51	0.03	2937	5052	63	12.0
12/4/2012 9:45	0.82	0.05	8116	2437	23	42.9
12/11/2012 11:20	0.33	0.02	3119	918	23	30.9
12/15/2012 9:10	0.38	0.03	2600	490	16	24.3
12/16/2012 3:15	1.37	0.03	11554	4597	28	23.9
12/19/2012 2:10	1.85	0.03	20266	8113	29	21.0
12/23/2012 5:15	0.44	0.01	4298	61	1	17.8
12/25/2012 3:10	1.13	0.02	10044	2620	21	17.0
1/6/2013 19:50	0.56	0.02	4812	226	4	25.7
1/24/2013 17:50	0.5	0.02	3096	51	2	25.0
New Pre-Filter Installed 1/27/2013 (Cubed BioMediaGREEN)						
2/22/2013 9:30	0.67	0.03	9209	1442	14	38.6
3/19/2013 15:35	1.03	0.04	11259	3555	24	31.8
4/5/2013 14:20	0.63	0.09	4349	2182	33	32.3
4/8/2013 16:45	0.71	0.02	6524	131	2	18.2
4/10/2013 8:50	0.15	0.05	1468	157	10	26.1
New Pre-Filter Installed 5/9/2013 (Cubed BioMediaGREEN)						
5/16/2013 12:15	0.17	0.08	1422	440	24	47.6
5/21/2013 11:15	0.43	0.06	3522	543	13	45.6
5/22/2013 5:40	2.78	0.05	22799	24475	52	31.8
5/27/2013 2:20	0.76	0.1	8473	1213	13	21.9
5/28/2013 17:45	0.55	0.03	4280	3058	42	19.0

gpm: gallons per minute

Performance in Relation to Design Treatment Goal

The water quality treatment goal for the AMWS test system was to capture and treat 91 percent of the average annual runoff volume. Precipitation and flow data measured during storms that produced bypass flow are presented in Table 6. These data indicate that the AMWS test system bypassed during 49 out of 81 qualifying storm events that occurred from April 1, 2012, through May 31, 2013. The system was able to treat 75 percent of the total 14-month volume. Consequently, the goal of treating 91 percent of the volume from the site was not achieved. This was due to the high clay content loading to the AMWS of the runoff clogging the media cartridge pre-filter in the Pre-treatment Chamber (see *Maintenance Schedule* section above) and the fact that the system was undersized by a factor of 2.3 (see *Test System Sizing* section). Analysis of the rainfall and flow data at the end of the project indicated that, on average, the 1.54-inch storm (the 6-month event for the region) produced a peak storm discharge of 95 gallons per minute. If the system was sized correctly (i.e., to treat 100 percent of the 6-month storm), then the design flow rate should have been equivalent to approximately 95 gpm, instead it was sized to 41 gpm (undersized by a factor of 2.3). The maintenance frequency is discussed in more detail below.

Treated Flow Rate during Bypass

In order to investigate system performance over the course of the study period, peak treated flow rate during bypass was assessed as a function of time. During bypass, 2.3 feet of the WetlandMedia is activated, so the peak treated flow rate during bypass should be at or above the water quality design flow rate. If this flow rate consistently falls below the design flow rate, it is likely that the pre-filter media is clogging. Figure 10 presents a plot of treated bypass flow rate through the course of the 14-month study. As is apparent, the treated flow rate decreases between each pre-filter change. In the three periods during which the cubed BioMediaGREEN was installed, the time it took for the treated flow rate to drop to 50 percent of the design flow rate ranged from 1 month to 3 months. These data indicate that for an undersized system with a pre-filter sized at 3.0 gpm/sq ft located at an industrial site with fine TSS loading, such as that observed at the Albina Maintenance Facility testing site, a maintenance interval of 2 to 3 months would be appropriate. If the MWS-Linear system is granted TAPE approval, site-specific maintenance intervals and pre-filter configurations will be determined for each installation. Under more typical loading conditions and with proper unit sizing and pre-filter configuration, the manufacturer expects the maintenance interval to be between 6 and 24 months due to the high variation of loading from site to site. With each replacement of BioMediaGREEN in the pre-filters the MWS-Linear once again was able to operate near the original peak treatment flow rate of 41 gpm indicating that the wetland chamber and its WetlandMedia was protected from clogging by the pre-filters and orifice control. Considering that minimal clogging was observed in the wetland chamber it can be anticipated the WetlandMedia will not need to be maintained for several years.

Water Quality Data

This section summarizes water quality data collected during the monitoring period at the AMWS, including a comparison of data compiled over this period with guidelines identified by Ecology (2011) for assessing data acceptability. Monitoring results for each parameter are summarized and discussed in separate sections. Field forms completed by staff during

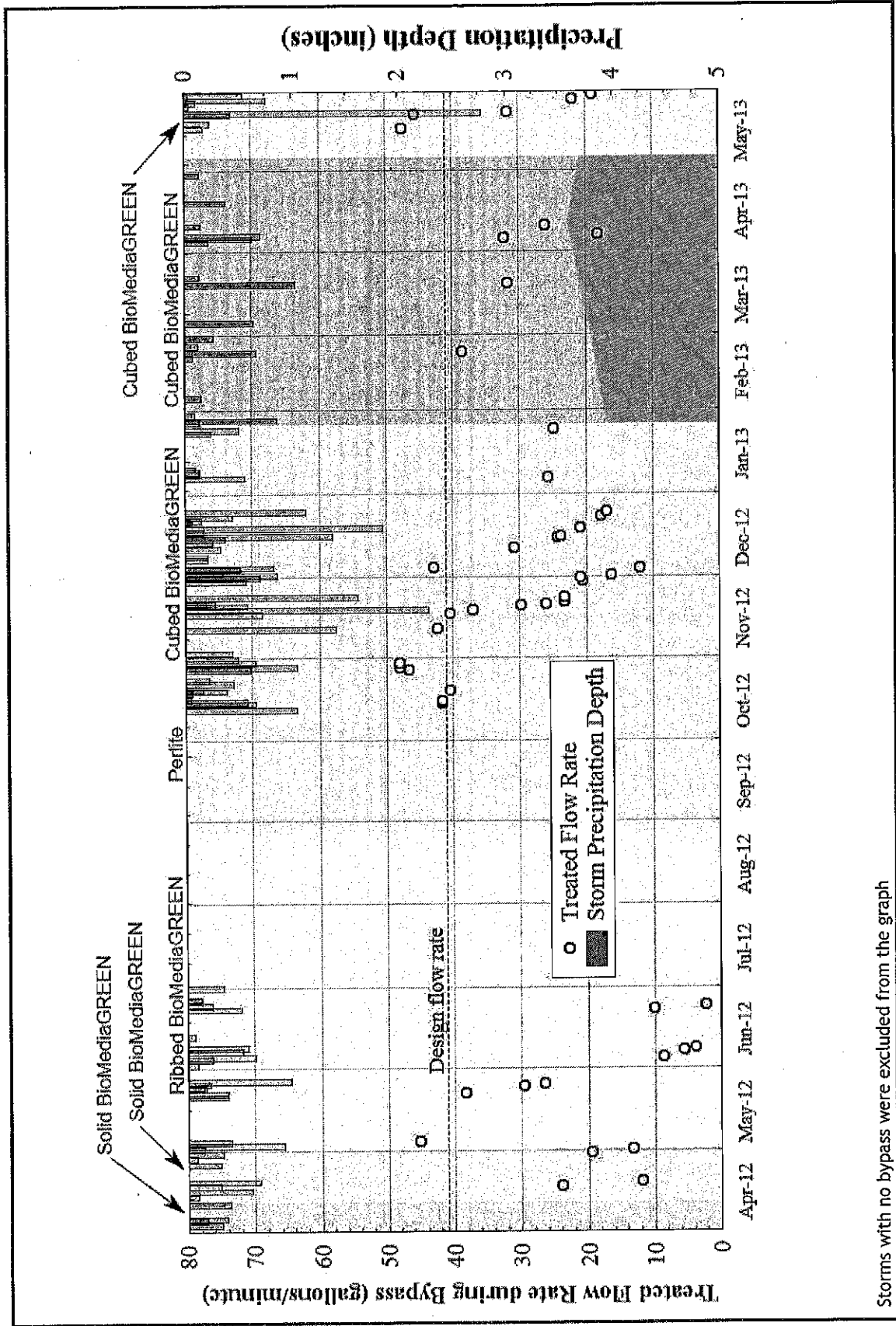

Storms with no bypass were excluded from the graph

Figure 10. Temporal Plot of Peak Treated Flow Rate during Bypass and Storm Precipitation Depth.

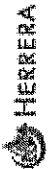

each sampling visit are presented in Appendix G. Individual Storm Reports showing sample collection times in relation to influent and effluent hydrographs are presented in Appendix H for all sampled storm events. In addition, laboratory reports for each sampled event are presented in Appendix I.

Comparison of Data to TAPE Guidelines

Ecology (2011) provides guidelines for determining data acceptability based on the characteristics of sampled storm events and the collected samples. The data collected through this monitoring effort are evaluated relative to these guidelines in the following subsections. In this section, only the data that are being submitted as valid for TAPE certification are presented. Water quality and hydrologic data from all events, including those that did not meet the TAPE criteria, are presented in Appendix F.

Storm Event Guidelines

During the April 14, 2012, through May 31, 2013 monitoring period, 28 storm events were sampled to characterize the water quality treatment performance of the AMWS Filter test system. Precipitation data from the sampled storm events was compared to the following TAPE storm event guidelines:

- **Minimum precipitation depth:** 0.15 inches
- **Minimum antecedent dry period:** 6 hours with less than 0.04 inches of rain
- **Minimum storm duration:** 1 hour
- **Minimum average storm intensity:** 0.03 inches per hour for at least half the sampled storms

Summary data related to these guidelines are presented in Table 7 for each of the 28 sampled storm events. These data show the guideline for minimum precipitation depth (0.15 inch) was met during all storm events except the April 29, 2013, event. Because it was determined that the precipitation gauge may have been overestimating rainfall by 17 percent, two additional storms may have not met the minimum storm depth requirement of 0.15 inches: the April 10, 2013, and the May 16, 2013, event (Table 7). All three of these events had precipitation intensities that exceeded 0.03 inches/hour, so they were included in the final data set and analyzed herein. The minimum, median, and maximum precipitation depths across all 28 sampled storm events were 0.14, 0.51, and 2.27 inches, respectively. The guideline for minimum antecedent dry period (6 hours) was met for all 28 of the events. The storm duration criteria (1 hour) was also met for all 28 storm events except the April 19, 2013, event which was a short intense event lasting 0.3 hours. The April 19, 2013, event was included in the final analysis because it met other storm and sampling requirements. Antecedent dry periods during the sampled storm events ranged from 9.5 to 416.8 hours, with a median value of 33.3 hours. Storm durations ranged from 0.3 to 35.2 hours, with a median value of 10.0 hours (Table 7).

Table 7. Comparison of Precipitation Data from Sampled Storm Events at the AMWS Test System to Storm Event Guidelines in the TAPE.

Storm Start Date & Time	Storm Precipitation Depth (in)	Storm Antecedent Dry Period (hours)	Storm Precipitation Duration (hours)	Average Storm Intensity (inches/hour) ^b
4/15/2012 22:45	0.60	51.4	10.1	0.06
4/17/2012 21:20	0.31	36.8	9.2	0.034
4/19/2012 8:30	0.68	28.6	9.3	0.073
4/25/2012 20:50	0.31	13	9.8	0.032
5/2/2012 21:50	0.90	29.8	15.4	0.058
5/21/2012 4:45	0.38	16.8	13.4	0.028
10/14/2012 19:15	0.65	45.9	6.7	0.097
10/15/2012 12:30	0.58	10.9	8.5	0.068
10/28/2012 6:15	1.04	10	23.3	0.045
10/29/2012 22:45	0.65	18.8	17.2	0.038
10/31/2012 5:25	0.49	16.1	33.3	0.015
11/23/2012 8:25	1.61	44.5	17.8	0.091
11/29/2012 6:15	0.57	20	31.2	0.018
12/2/2012 14:10	0.35	9.5	25.8	0.014
12/3/2012 22:30	0.51	13	4.3	0.118
12/11/2012 11:20	0.33	44.5	7.4	0.044
12/19/2012 2:10	1.85	17.4	35.2	0.052
1/23/2013 12:15	0.25	214.1	4.7	0.054
1/24/2013 17:50	0.50	25.7	16.8	0.03
2/22/2013 9:30 ^a	0.67	41.6	6.4	0.104
3/19/2013 15:35 ^a	1.03	71.7	16	0.064
4/4/2013 8:00	0.22	305.2	7.5	0.029
4/6/2013 16:45	0.71	10.5	30.8	0.023
4/10/2013 8:50	0.15	63.5	3.2	0.047
4/18/2013 20:45	0.39	69.9	10.9	0.036
4/29/2013 3:15	0.14	236.4	0.3	0.420
5/16/2013 12:15 ^a	0.17	416.8	4.8	0.036
5/21/2013 11:15 ^a	0.43	67	6.3	0.068
Minimum	0.14	9.5	0.3	0.014
Median	0.51	33.3	9.95	0.046
Maximum	2.27	416.8	35.2	0.420

Values in bold do not meet storm event guidelines recommended in the TAPE (Ecology 2011).

Values in *italics* indicate the events which may not meet the TAPE guidelines for precipitation depth because the project precipitation gauge may not have been properly calibrated.

^a All sampled events were flow-weighted composite sampled except these events, which consisted of samples collected above a high flow rate threshold.

^b Majority of events exceeded the 0.03 in/hr rainfall intensity criteria

The minimum average storm intensity of 0.03 inches per hour was achieved for 80 percent of the sampled storm events (Table 7). The TAPE storm event guidelines recommend this threshold for at least half of the sampled storms; consequently this criterion was also met.

Sample Collection Guidelines

As described in the methods section, automated samplers were programmed with the goal of meeting the following criteria for acceptable composite samples that are identified by Ecology (Ecology 2011):

- A minimum of 10 aliquots were collected for each event.
- Sampling was targeted to capture at least 75 percent of the hydrograph.
- Due to sample holding time considerations, the maximum duration of automated sample collection at all stations was 36 hours.

The guideline for minimum number of sample aliquots (10) was met for all of the sampled storm events (see Table 8). It should be noted that 4 of the 28 sampled events were peak flow sample events, not flow weighted composites. The TAPE (2011) indicates that samples must represent a wide range of treated flows; in order to get samples representative of the highest treated flow rates discrete peak flow sampling is required.

The criterion for minimum portion of storm volume covered by sampling (75 percent) was met for all but one of the sampled flow-weighted storm events (see Table 8). The December 19, 2012, event had 71 percent sampling coverage. This was deemed close enough to 75 percent and the sample was included for analysis.

Table 8. Comparison of Flow-weighted Composite Data from Sampled Storm Events at the AMWS Test System to Criteria in the TAPE.			
Storm Start Date & Time	Influent and Effluent Sample Aliquots (#)	Influent and Effluent Storm Coverage (%)	Influent and Effluent Sampling Duration
4/15/2012 22:45	18	92.3	8.6
4/17/2012 21:20	31	97.9	8
4/19/2012 8:30	32	95.1	6.8
4/25/2012 20:50	50	98	5.4
5/2/2012 21:50	75	81.4	10.4
5/21/2012 4:45	53	96.7	9.7
10/14/2012 19:15	35	96.5	6.5
10/15/2012 12:30	39	98	5.9
10/28/2012 6:15	74	94.9	16.1
10/29/2012 22:45	31	95.3	14.7
10/31/2012 5:25	33	94.4	23.9
11/23/2012 8:25	80	77.3	12.9
11/29/2012 6:15	63	98.4	24.1
12/2/2012 14:10	24	77.5	19.2
12/3/2012 22:30	10	83.4	3.8
12/11/2012 11:20	69	97.3	4.2
12/19/2012 2:10	80	71	23.7
1/23/2013 12:15	32	99.2	6.1
1/24/2013 17:50	20	88.7	12.8
2/22/2013 9:30 ^a	20	NA	0.4
3/19/2013 15:35 ^a	55	NA	0.8
4/4/2013 8:00	12	89.4	5.3
4/6/2013 16:45	36	96.8	27.8
4/10/2013 8:50	41	95.6	5.3
4/18/2013 20:45	56	96.6	7.3
4/29/2013 3:15	24	91.2	3.3
5/16/2013 12:15 ^a	20	NA	0.4
5/21/2013 11:15 ^a	12	NA	0.2
Minimum	10	71	0.2
Median	35	95.2	7.3
Maximum	80	99.2	27.8

Values in bold do not meet storm event guidelines recommended in the TAPE (Ecology 2011)

NA = not applicable

^a All sampled events were flow-weighted composite sampled except these events, which consisted of samples collected above a high flow rate threshold

PERFORMANCE EVALUATION

This section evaluates water quality data based on treatment goals addressed in this TER.

Particle Size Distribution

The TAPE guidelines state that Pacific Northwest stormwater typically contains mostly silt-sized particles; thus, PSD results should be provided to indicate whether the stormwater runoff analyzed is consistent with particle sizes typically found in urban runoff in this region.

Two separate laboratories were used for PSD analysis. For the first 18 events, Chemoptix, Inc. was used, while Analytical Resources, Inc. was used for the last 10 events. The laboratories were switched due to inadequate service from the first laboratory and the fact that they could not bin the PSD data in the desired format. The separate PSD results obtained from the Chemoptix, Inc. and Analytical Resources, Inc. are shown in Figures 11 and 12, respectively.

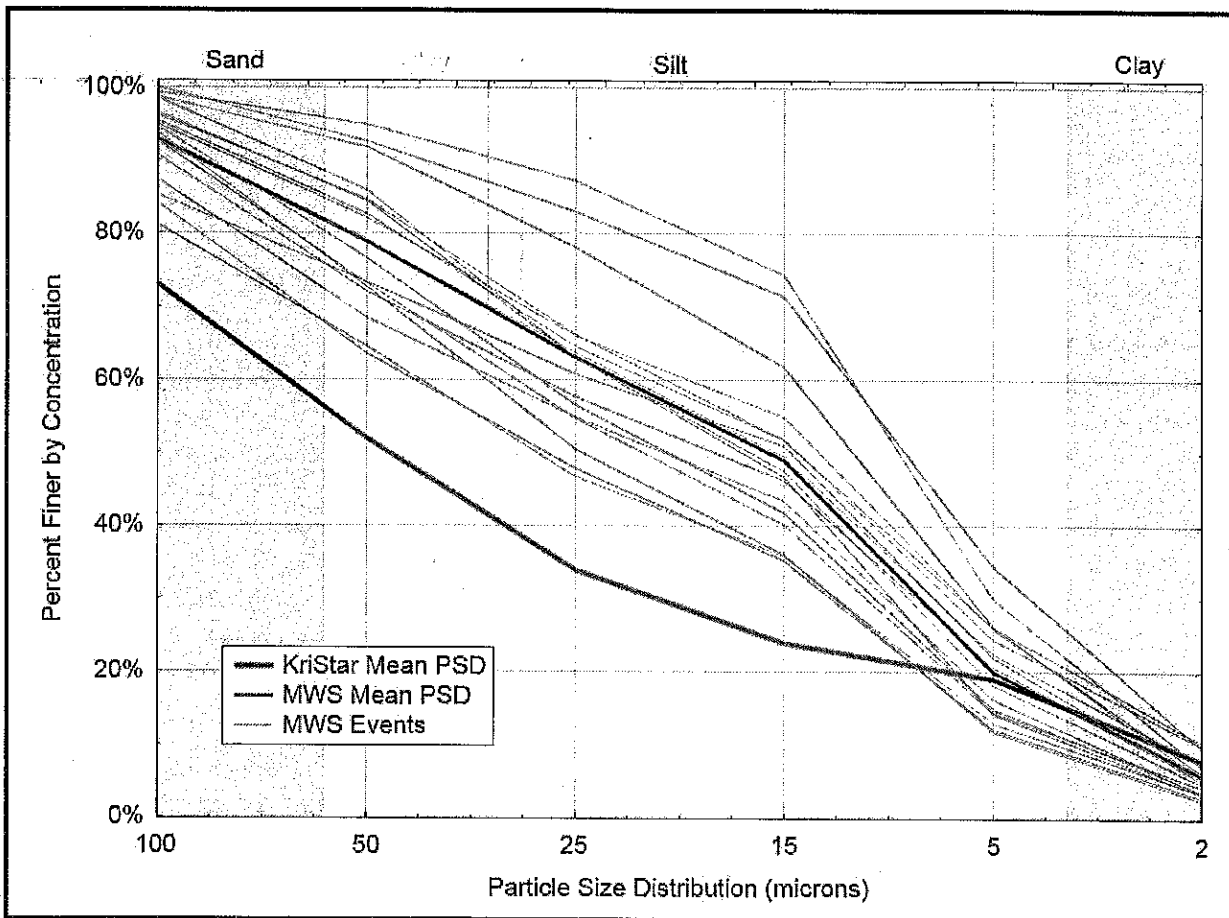

Figure 11. Influent PSD Results from Chemoptix (First 18 Samples).

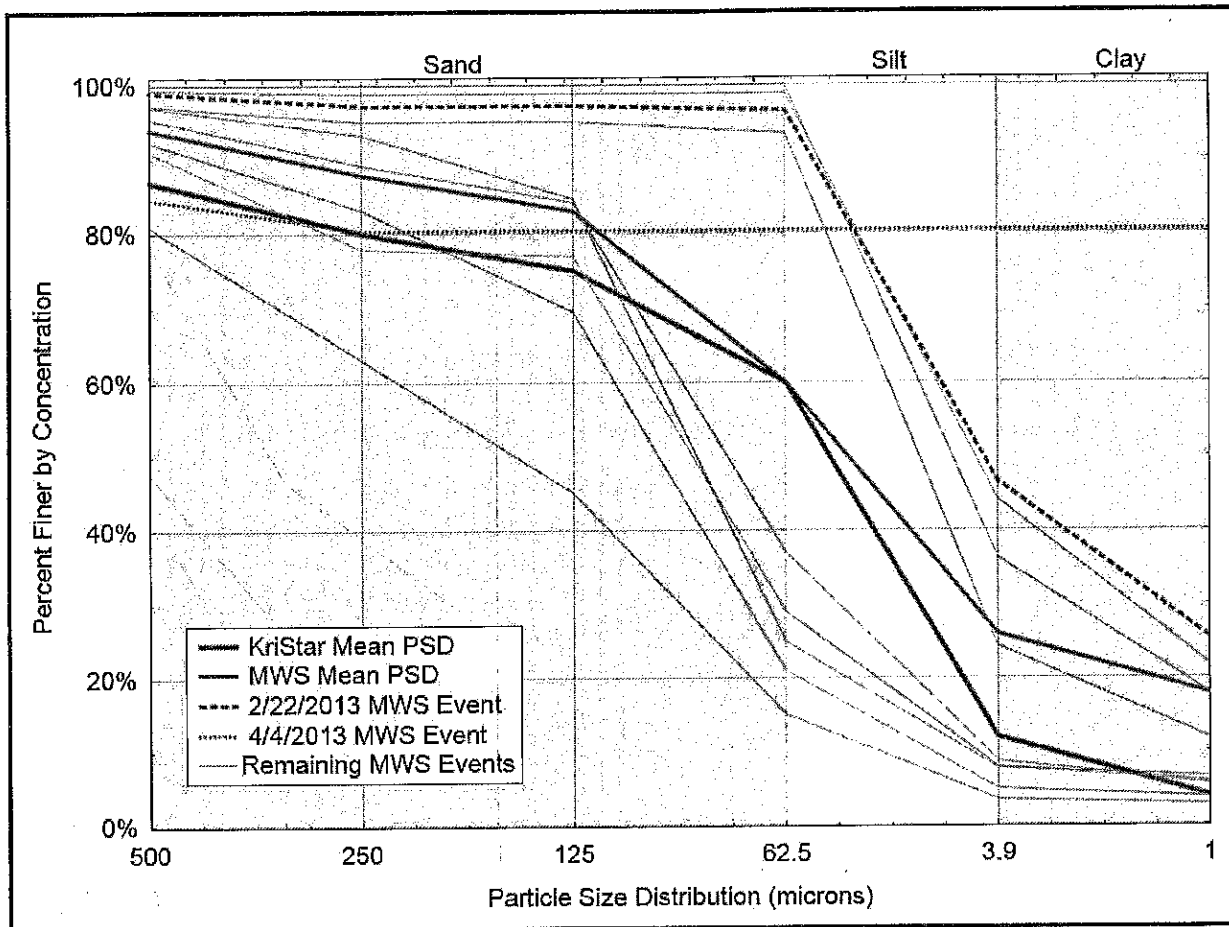

Figure 12. Influent PSD Results from Analytical Resources, Inc. (Last 10 Samples).

In Figure 11, it is apparent that the suspended solids in the stormwater are mostly comprised of silt sized particles. As was indicated in the *Maintenance Schedule* section above, the stormwater at the AMWS test site was unusually turbid. In order to quantify this, the mean PSD from a previous TAPE monitoring project (KriStar Perk Filter) was plotted with the AMWS data in Figure 11. As is apparent from Figure 11, there is 25 percent more silt at the AMWS site and an equivalent amount of clay when compared to the KriStar PSD. A somewhat similar pattern was observed with the PSD results from Analytical Resources, Inc. (Figure 12). Figure 12 shows there is, on average, equivalent silt content between AMWS and the KriStar data and 14 percent more clay at the AMWS site. In both cases, the data clearly show that significantly more fine sediment (either silt or clay) was being exported from the AMWS site than was from the KriStar site.

This comparison helps explain why the pre-filters were clogging at the AMWS site (see *Maintenance Schedule* and *Treated Flow Rate during Bypass* sections above). Figure 12 also highlights two events that produced PSD results that are considered outliers. The PSD results from the April 4, 2013, event indicated that 80 percent of the suspended solids were finer than clay (colloidal). This was deemed a spurious result and the PSD results were not used in calculating the mean PSD for the site; however, the chemistry results for the same sample appeared typical so they were included in the final analyses. Also noted on Figure 12 is the

PSD result from February 22, 2013. This sample exhibited the highest clay content (47 percent) of any of the accepted samples and was characterized by only 61 percent TSS removal (see *Basic Treatment* section below).

Basic Treatment

The basic treatment goal listed in the TAPE guidelines indicate that the bootstrapped 95 percent lower confidence interval (LCL95) of the mean total suspended solids (TSS) removal must be greater than or equal to 80 percent for influent concentrations ranging from 100 to 200 mg/L. For influent TSS concentrations less than or equal to 100 mg/L but greater than 20 mg/L, the upper 95 percent confidence interval (UCL95) of the mean effluent concentration must be less than or equal to 20 mg/L. There is no specified criterion for influent TSS concentrations less than 20 mg/L; consequently, those sample pairs (influent and effluent) cannot be used for assessment of TSS removal performance. For influent concentration that exceed 200 mg/L, the treatment goal is an LCL95 of greater than an 80 percent reduction. Additionally, it must be shown that a statistically significant difference between influent and effluent concentrations exists. Finally, pollutant removals that meet the TAPE goals must be shown for sample pairs across a range of treated flow rates up to and including the design flow rate. This section describes the sampling results in relation to these criteria based on data from 24 events where influent concentrations were greater than 20 mg/L.

Before any performance analyses were conducted, the dataset was analyzed in relation to the different pre-filters configurations that were installed during monitoring. Due to issues associated with the high clay content of the runoff, the pre-filter design had to be altered during the course of the monitoring project. This resulted in samples being collected with four different types of pre-filters: BioMediaGREEN blocks, ribbed BioMediaGREEN blocks, perlite, and finally BioMediaGREEN cubes. The manufacturer plans to use cubed BioMediaGREEN for all future MWS-Linear installations; consequently, a statistical test was run to indicate if the cubed BioMediaGREEN performed differently than the other pre-filters types. Specifically, a Mann-Whitney U-test was run on the 16 TSS percent removal results collected with the cubed BioMediaGREEN versus the 8 collected with the other pre-filter configurations. The test indicated that there was no significant difference between the datasets ($p = 0.110$). Consequently, the data collected under all pre-filter configurations were combined for use in the following analyses.

A one-tailed Wilcoxon signed-rank test performed on the total suspended solids data with influent concentrations ≥ 20 mg/L ($n = 24$) indicated there was a statistically significant ($p < 0.001$) decrease in effluent total suspended solids concentrations compared to influent total suspended solids concentrations. Consequently, this aspect of the Basic Treatment criteria for TAPE was met.

The majority of the samples collected at AMWS had influent concentrations below 100 mg/L (Table 9). Of the 28 sampled events, 18 had influent concentrations between 20 and 100 mg/L. The UCL95 mean concentration for these 18 samples was 12.8 mg/L, which is below the 20 mg/L threshold and consequently these samples also show the Basic Treatment criteria for TAPE was met.

Seven of the sampled events were characterized by influent concentrations greater than 100 mg/L, with three events exceeding 200 mg/L (Table 9). The mean TSS removal for these events was 84.9 percent (above the 80 percent reduction criteria). While the mean TSS removal for the events with influent from 100 to 200 mg/L and >200 mg/L, was 90.8 and 77 percent, respectively (Table 9). An LCL95 mean removal was not calculable for these samples, since at least 10 samples are required for a bootstrap analysis. However, these samples were used in the assessment of removal efficiency at various treatment flow rates.

Because flow-weighted composite sampling consists of combined samples collected across a wide range of flow rates through the entire storm hydrograph, the resultant average sampled treated flow rate for a given composite sample will almost always be below the design flow rate. In order to see how the system performed at higher flow rates discrete "peak flow" samples had to be collected (see Table 9). A potential ramification of having most of the samples collected below the design flow rate is that the average percent removal result will be biased high. This is based on the assumption that treatment will be more efficient at lower flow rates through the filter. Figure 13 displays percent removal as a function of treated flow rate. As can be seen from this figure, there is no trend indicating that lower treated flow rates produced higher percent removal results. Consequently, we posit that the sampling design is not biased and is sufficient to determine treatment performance across a range of flow rates.

To determine with what flow rates the TSS removals were associated, the flow rate at the point when each aliquot was collected was calculated. These flow rates were then averaged for each sampled event. As shown in Table 9, these results indicate the mean sampled treated flow rate was 17.3 gpm. As described in the *Test System Sizing* section above, the design flow rate for the system is 41 gpm. Figure 13 displays percent removal versus average treated flow rate for all of the 24 qualifying TSS sample pairs. For reference, the open blue dots on the figure are sample pairs with influent less than 100 mg/L while the solid red dots are sample pairs with influent TSS from 100 - 200 mg/L, and the black squares represent sample pairs with influent TSS > 200 mg/L. The TAPE (Ecology 2011) indicates that a regression analysis should be conducted to determine the treatment efficiency varies as function of treated flow rate. The results of the regression analysis indicated there is no significant relationship between treatment efficiency and treated flow rate ($p = 0.822$).

Visual examinations of the relationship between treatment efficiency and treated flow rate in Figure 13 highlight the anomalous results from the February 22, 2013, event. As indicated in the *Particle Size Distribution* section above, the influent sample for this event was characterized by 47 percent suspended clay, 21 percent more clay than the average for the site. This may explain why the TSS removal for this sample pair was so low. If this data point is removed, it is clear that the TSS removal is above 80 percent up to and through the design flow rate of 41 gpm. In addition, it appears as if the system is capable of removing TSS at flow rates up to 50 gpm.

Taken together, the above analyses indicate that the Basic Treatment criteria were met based on the data collected at the AMWS test site.

Table 9. Total Suspended Solids Concentrations and Removal Efficiency Estimates for Valid Sampling Events at the AMWS Test System.

Storm Start Date & Time	Influent Conc. (mg/L)	Qualifier	Effluent Conc. (mg/L)	Qualifier	Effluent Conc. (ln = 20-100) (mg/L)	% Removal (ln = 100-200)	% Removal (ln >200)	Sampled Flow Rate (gpm) ^b	Max Treated Flow Rate (gpm)	Bypass?
4/15/2012 22:45	26		2.8		2.8			7	16.5	
4/17/2012 21:20	100		2.3		2.3	98		13	24.1	✓
4/19/2012 8:30	46		4.8		4.8			6	12.0	✓
4/25/2012 20:50	20		3.2		3.2			10	24.1	
5/2/2012 21:50	32		3		3			15	35.8	
5/21/2012 4:45	70		12		12			22	33.3	
10/14/2012 19:15	26		7.4		7.4			28	41.8	✓
10/15/2012 12:30	67		17		17			28	41.8	✓
10/28/2012 6:15	22		4.1		4.1			26	48.0	✓
10/29/2012 22:45	67		12		12			23	48.0	✓
10/31/2012 5:25	30		11		11			6	12.7	
11/23/2012 8:25	6.5		1.7					19	23.4	✓
11/29/2012 6:15	34.2		18		18			10	21.0	✓
12/2/2012 14:10	6.7		2.6					5	10.2	
12/3/2012 22:30	22.8		6.7		5.7			11	12.0	✓
12/11/2012 11:20	6.7		5					19	30.9	✓
12/19/2012 2:10	48.7		5.5		5.5			17	21.0	✓
1/23/2013 12:15	42		26.7		26.7			6	10.2	
1/24/2013 17:50	41.2		14.3		14.3			8	25.0	✓
2/22/2013 9:30 ^a	339		132				61	40	38.6	✓
3/19/2013 15:35 ^a	209		47				78	28	31.8	✓
4/4/2013 8:00	145	J	19			87		3	5.5	
4/6/2013 16:45	12		2.1					11	18.2	✓
4/10/2013 8:50	163		17			89		13	26.1	✓
4/18/2013 20:45	20.6		2.6		2.6			9	14.3	
4/29/2013 3:15	186		21			89		20	37.0	
5/16/2013 12:15 ^a	251		20.8				92	50	47.6	✓
5/21/2013 11:15 ^a	79		20.6		20.5			28	45.6	✓
n	28		28		18	4	3	28	28	
UCL95 Mean ^c					12.3					
Mean	75.0		15.7		9.5	90.8	77.0	17.3	27.0	
LCL95 Mean ^d										

^a All sampled events were flow-weighted composite sampled except these events, which consisted of samples collected above a high flow rate threshold (per TAPE requirements).

^b Sampled flow rate is calculated by averaging the instantaneous flow rate associated with each aliquot in the composite sample.

^c Bootstrapped estimate of the upper 95% confidence limit of the mean. Only calculated for effluent concentration with influent between 20 and 100 mg/L per the TAPE (Ecology 2011).

^d Bootstrapped estimate of the lower 95% confidence limit of the mean. Only calculated for percent removal when influent ≥ 100 mg/L per the TAPE (Ecology 2011). Not calculated for this data set because n value was too low for bootstrap procedure.

Bold values met influent screening criteria and were used in performance analyses.

J = estimated value based on water quality data (Appendix E)

gpm = gallons/minute

mg/L = milligram/liter

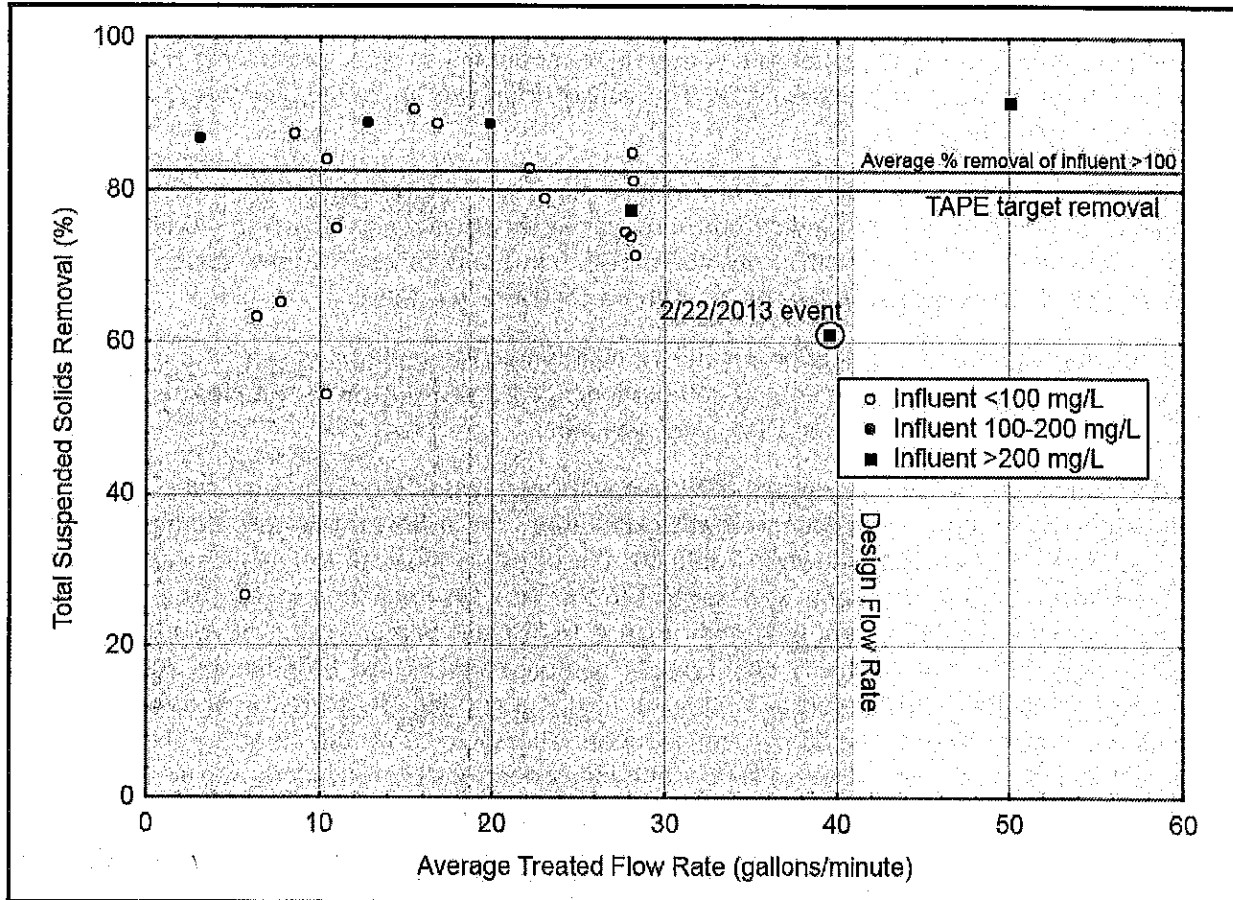

Figure 13. TSS Removal (%) as a Function of Average Treated Flow Rate.

Phosphorus Treatment

The phosphorus treatment goal listed in the TAPE guidelines indicates that the LCL95 of the mean removal must be greater than or equal to 50 percent for influent total phosphorus (TP) concentrations ranging from 0.1 to 0.5 mg/L. In addition, it must be shown that a statistically significant difference between influent and effluent concentrations exists. Finally, pollutant removals that meet the TAPE goals must be shown for sample pairs across a range of treated flow rates up to and including the design flow rate. This section describes the sampling results in relation to this criterion based on data from 17 events where influent concentrations were within the specified target range.

Before any performance analyses were conducted, the dataset was analyzed in relation to the pre-filters that were installed during monitoring. Specifically, a Mann-Whitney U-test was run on the 10 qualifying TP percent removal results collected with the cubed BioMediaGREEN versus the 7 collected with the other pre-filter configurations. The test indicated that there was no significant difference between the datasets ($p = 0.482$). Consequently, the data collected under all prefilter configurations were combined for use in the following analyses.

It should also be noted that one of the data points used in the analyses presented herein is an orthophosphorus result instead of a TP result. A high flow rate sample was collected on

May 16, 2013, but the sample was mistakenly not analyzed for TP. Orthophosphorus was used in lieu of TP for this event, which is a conservative approach as orthophosphorus is more difficult to treat and remove than is TP. This substitution was approved by Ecology in a meeting held on June 5, 2013.

A one-tailed Wilcoxon signed-rank test performed on the TP data with influent concentrations from 0.1 to 0.5 mg/L (n = 19) indicated there was a statistically significant ($p < 0.001$) decrease in effluent TP concentrations compared to influent concentrations. Consequently, this aspect of the Phosphorus Treatment criteria for TAPE was met.

The LCL95 mean percent reduction for the 17 qualifying TP sample pairs was 57.6 percent (Table 10), which is above the goal of ≥ 50 percent; consequently, these samples also show the Phosphorus Treatment criteria for TAPE was met.

To determine with what flow rates the TP removals were associated, the flow rate at the point when each aliquot was collected was calculated. These flow rates were then averaged for each sampled event. As shown in Table 10, these results indicate the mean sampled treated flow rate was 17.3 gpm. As described in the *Test System Sizing* section above, the design flow rate for the system is 41 gpm. Figure 14 displays percent removal versus average treated flow rate for all of the 17 qualifying TP sample pairs. Figure 14 indicates the high flow rate orthophosphorus result as well as all of the qualifying TP results. As is apparent, only one result fell below the 50 percent reduction threshold. It should be noted that in Figure 14, it is apparent that there is no trend indicating that there is increased TP removal at lower treated flow rates. Consequently, the LCL95 mean removal of 57.6 percent is not biased by the fact that the majority of the samples were collected below the design flow rate.

The results of the regression analysis on the percent removal versus flow rate data indicated there is no significant linear relationship between these variables ($p = 0.834$). A visual assessment of the data in Figure 14 also indicates treatment efficiency greater than 50 percent is evident up to and through the design flow rate; therefore, it can be safely assumed that the system can reduce TP by greater than 50 percent at the design flow rate of 41 gpm. In addition, it appears as if the system can effectively remove phosphorus at flow rates up to 50 gpm (Figure 14).

Taken together, the above analyses indicate that the Phosphorus Treatment criteria were met based on the data collected at the AMWS test site.

Enhanced Treatment

The TAPE enhanced treatment criteria indicate that the LCL95 of the mean dissolved zinc removal must be greater than 60 percent for influent concentrations ranging from 0.02 to 0.3 mg/L. In addition, the LCL95 of the mean dissolved copper removal must be greater than 30 percent for influent concentrations ranging from 0.005 to 0.02 mg/L. In addition, it must be shown that a statistically significant difference between influent and effluent concentrations exists. Finally, pollutant removals that meet the TAPE goals must be shown for sample pairs across a range of treated flow rates up to and including the design flow rate. Separate subsections below describe the sampling results in relation to these criteria based

Table 10. Total Phosphorus Concentrations and Removal Efficiency Estimates for Valid Sampling Events at the AMWS Test System.

Storm Start Date & Time	Influent Conc. (mg/L)	Qualifier	Effluent Conc. (mg/L)	Qualifier	% Removal (In= 0.1-0.5) ^b	Sampled Flow Rate (gpm) ^c	Max Treated Flow Rate (gpm)	Bypass?
4/15/2012 22:45	0.092		0.026		72	7	16.5	
4/17/2012 21:20	0.14	J	0.02	U	86	13	24.1	✓
4/19/2012 8:30	0.087	J	0.1	U		8	12.0	✓
4/25/2012 20:50	0.15		0.062		59	10	24.1	
5/2/2012 21:50	0.090		0.038		58	15	35.6	
5/21/2012 4:45	0.18		0.062		66	22	33.3	
10/14/2012 19:15	0.18	✓	0.079		56	28	41.8	✓
10/15/2012 12:30	0.098	✓	0.01		90	28	41.8	✓
10/26/2012 6:15	0.068	✓	0.039			28	48.0	✓
10/29/2012 22:45	0.13	✓	0.041		68	23	48.0	✓
10/31/2012 5:25	0.1		0.039		61	6	12.7	
11/23/2012 8:25	0.026	✓	0.1	U		19	23.4	✓
11/29/2012 6:15	0.093	✓	0.036		61	10	21.0	✓
12/2/2012 14:10	0.027		0.01			5	10.2	
12/3/2012 22:30	0.075	✓	0.023			11	12.0	✓
12/11/2012 11:20	0.257	✓	0.054		79	19	30.9	✓
12/19/2012 2:10	0.073	✓	0.025			17	21.0	✓
1/23/2013 12:15	0.103		0.083		19	6	10.2	
1/24/2013 17:50	0.098	✓	0.039		60	8	25.0	✓
2/22/2013 9:30 ^a	0.56	✓	0.26			40	38.6	✓
3/19/2013 15:35 ^a	0.398	✓	0.13		67	28	31.8	✓
4/4/2013 8:00	2.15	J	0.4			3	5.5	
4/6/2013 16:45	0.165	✓	0.041		75	11	18.2	✓
4/10/2013 8:50		✓				13	26.1	✓
4/18/2013 20:45						9	14.3	
4/29/2013 3:15	0.1					20	37.0	
5/16/2013 12:15 ^a	0.114 ^f	✓	0.05 ^f		56 ^f	50	47.6	✓
5/21/2013 11:15 ^a	0.212	✓	0.1		53	28	45.6	✓
n	25		25		17	28	28	
UCL95 Mean ^d								
Mean	0.231		0.076		63.9	17.3	27.0	
LCL95 Mean ^e					57.6			

^a All sampled events were flow-weighted composite sampled except these events, which consisted of samples collected above a high flow rate threshold.

^b Percent removal is only calculated for sample pairs with influent 0.1 - 0.5 mg/L.

^c Sampled flow rate is calculated by averaging the instantaneous flow rate associated with each aliquot in the composite sample.

^d Bootstrapped estimate of the upper 95% confidence limit of the mean. Only calculated for TSS effluent concentrations (not applicable for TP).

^e Bootstrapped estimate of the lower 95% confidence limit of the mean. Used to compare to the TAPE TP criteria of at least 50 percent removal.

^f Orthophosphorus results used in lieu of TP results for this event (due to missing TP data).

Bold values met influent screening criteria and were used in performance analyses

J = estimated value based on water quality data (Appendix E)

U = result at or below the reporting limit

gpm = gallons/minute

mg/L = milligram/liter

on data from 11 and 14 events where influent concentrations were within the specified ranges for dissolved zinc and copper, respectively.

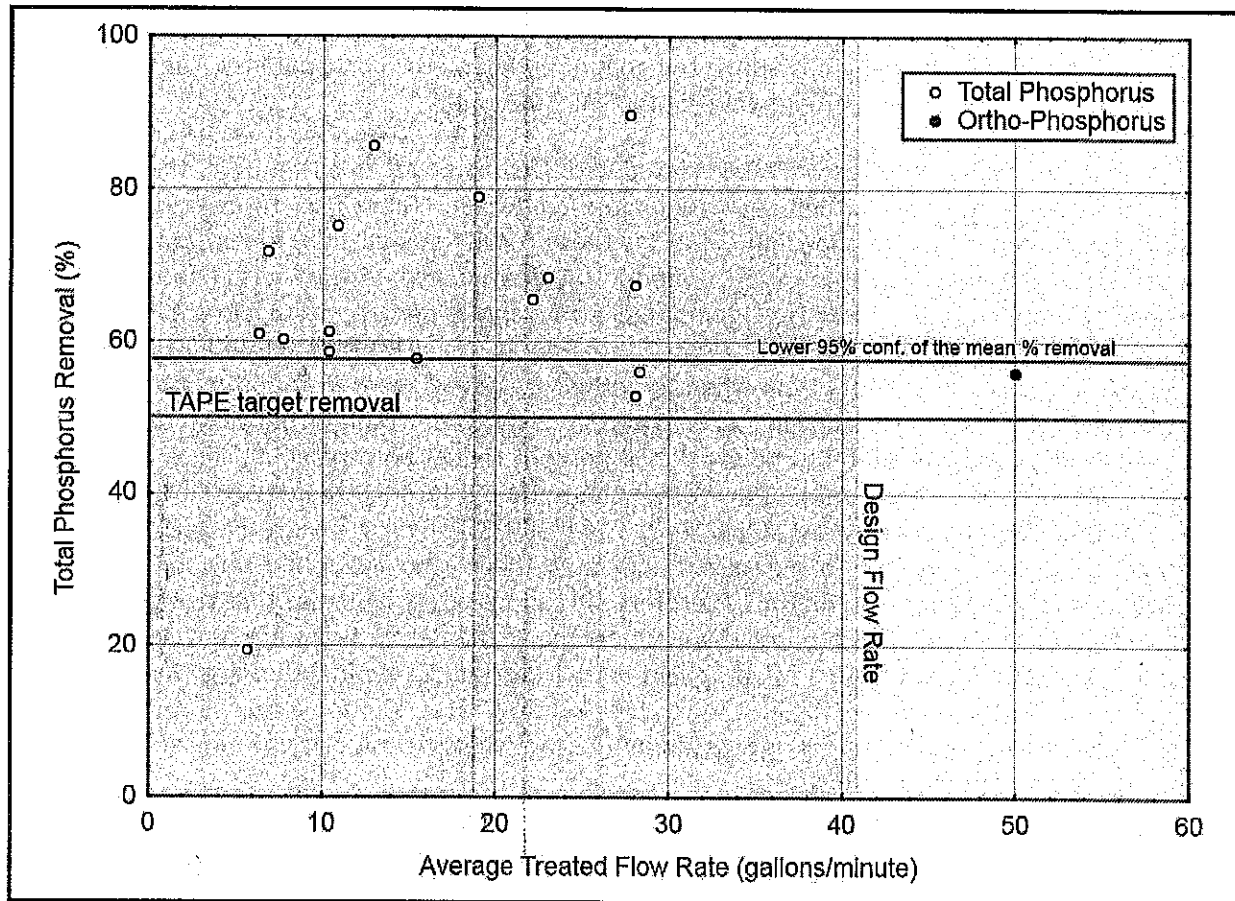

Figure 14. TP Removal (%) as a Function of Average Treated Flow Rate.

Dissolved Zinc Treatment

Before any performance analyses were conducted, the dissolved zinc dataset was analyzed in relation to the pre-filters, which were installed during monitoring. Specifically, a Mann-Whitney U-test was run on the 11 qualifying dissolved zinc percent removal results collected with the cubed BioMediaGREEN versus the 7 collected with the other pre-filter configurations. The test indicated that there was a significant difference between the datasets ($p = 0.004$). Consequently, only the data collected when the cubed BioMediaGREEN was installed were used in the final assessment. This results in a dataset with only 11 qualifying events. The TAPE indicates that 12 events are required. However, based on conversations with Douglas Howie of Ecology (June 5, 2013) and due to the challenging site conditions, 11 events was deemed adequate for this TER.

A one-tailed Wilcoxon signed-rank test performed on the dissolved zinc data with influent concentrations from 0.02 to 0.3 mg/L ($n = 11$) indicated there was a statistically significant ($p < 0.001$) decrease in effluent dissolved zinc concentrations compared to influent

concentrations. Consequently, this aspect of the Enhanced Treatment criteria for TAPE was met.

The LCL95 mean percent reduction for the 11 qualifying dissolved zinc sample pairs was 60.5 percent (Table 11), which is above the goal of ≥ 60 percent; consequently, these samples also show the Enhanced Treatment criteria for TAPE was met.

To determine what flow rates were associated with the dissolved zinc removals, the flow rate was calculated at the point when each aliquot was collected. These flow rates were averaged for each sampled event. As shown in Table 11, these results indicate the mean sampled treated flow rate was 17.3 gpm. As described in the *Test System Sizing* section above, the design flow rate for the system is 41 gpm. Figure 15 displays percent removal versus average treated flow rate for all of the 11 qualifying dissolved zinc sample pairs (closed red dots). Figure 15 indicates the results from when the other pre-filters were installed (open blue circles) for reference purposes only. As is apparent, only three results from when the cubed BioMediaGREEN was installed fell below the 50 percent reduction threshold. These three results occurred at lower sampled flow rates. Closer to and through the design flow rate, the percent reduction results exceed 60 percent. The results of the regression analysis on the percent removal versus flow rate data also indicated there is no significant relationship between these variables ($p = 0.707$). Therefore, it can be safely assumed that the system can reduce dissolved zinc by greater than 60 percent at the design flow rate of 41 gpm. It should be noted that in Figure 15 it is apparent that there is no trend indicating that there is increased dissolved zinc removal at lower treated flow rates. Consequently, the LCL95 mean removal of 60.5 percent is not biased by the fact that the majority of the samples were collected below the design flow rate.

Taken together, the above analyses indicate that the Enhanced treatment criterion for dissolved zinc in TAPE was met based on the data collected at the AMWS test site.

Dissolved Copper Treatment

Before any performance analyses were conducted, the dissolved copper dataset was analyzed in relation to the pre-filters, which were installed during monitoring. Specifically, a Mann-Whitney U-test was run on the nine qualifying dissolved copper percent removal results collected with the cubed BioMediaGREEN versus the five collected with the other pre-filter configurations. The test indicated that there was no significant difference between the datasets ($p = 0.797$). Consequently, the data collected under all pre-filter configurations were combined for use in the following analyses.

A one-tailed Wilcoxon signed-rank test performed on the dissolved copper data with influent concentrations from 0.005 to 0.02 mg/L ($n = 14$) indicated there was a statistically significant ($p < 0.001$) decrease in effluent dissolved copper concentrations compared to influent concentrations. Consequently, this aspect of the Enhanced Treatment criteria for dissolved copper in TAPE was met.

The LCL95 mean percent reduction for the 14 qualifying dissolved copper sample pairs was 32.5 percent (Table 12), which is above the goal of ≥ 30 percent; consequently, these samples also show the Enhanced Treatment criterion for dissolved copper in TAPE was met.

Storm Start Date & Time	Influent Conc. (mg/L)	Qualifier	Effluent Conc. (mg/L)	Qualifier	% Removal (In= 0.02-0.3) ^b	Sampled Flow Rate (gpm) ^d	Max Treated Flow Rate (gpm)	Bypass?
4/15/2012 22:45	0.029		0.02		31 (NA)	7	16.5	
4/17/2012 21:20	0.020		0.011		45 (NA)	13	24.1	✓
4/19/2012 8:30	0.011		0.01	U		6	12.0	✓
4/25/2012 20:50	0.060		0.056		7 (NA)	10	24.1	
5/2/2012 21:50	0.022		0.012		45 (NA)	15	35.8	
5/21/2012 4:45	0.06		0.033		45 (NA)	22	33.3	
10/14/2012 19:15	0.031		0.012		61 (NA)	28	41.8	✓
10/15/2012 12:30	0.022		0.011		50 (NA)	28	41.8	✓
10/28/2012 6:15	0.015		0.0046			28	48.0	✓
10/29/2012 22:45	0.020		0.0074		63	23	48.0	✓
10/31/2012 5:25	0.015		0.0068			6	12.7	
11/23/2012 8:25	0.0107		0.0034			19	23.4	✓
11/29/2012 6:15	0.0108		0.0099			10	21.0	✓
12/2/2012 14:10	0.0146		0.006			5	10.2	
12/3/2012 22:30	0.013		0.0109			11	12.0	✓
12/11/2012 11:20	0.045		0.0133		70	19	30.9	✓
12/19/2012 2:10	0.0314		0.0072		77	17	21.0	✓
1/23/2013 12:15	0.0156		0.0076			6	10.2	
1/24/2013 17:50	0.0188		0.0069		65	8	25.0	✓
2/22/2013 9:30 ^a	0.0022		0.0060			40	38.6	✓
3/19/2013 15:35 ^a	0.0104		0.0122			28	31.8	✓
4/4/2013 8:00	0.352 ^a		0.1940		45 ^a	3	5.5	
4/6/2013 16:45	0.0338		0.0166		54	11	18.2	✓
4/10/2013 8:50	0.152		0.0652		57	13	26.1	✓
4/18/2013 20:45	0.299		0.0312		90	9	14.3	
4/29/2013 3:15	0.315 ^a		0.0610		81 ^a	20	37.0	
5/16/2013 12:15 ^a	0.0715		0.0238		67	50	47.6	✓
5/21/2013 11:15 ^a	0.0349		0.0136		61	28	45.6	✓
n	328		28		11	28	28	
UCL95 Mean ^e								
Mean	0.0620		0.0240		66.4	17.3	27.0	
LCL95 Mean ^f					60.5			

^a All sampled events were flow-weighted composite sampled except these events, which consisted of samples collected above a high flow rate threshold.
^b Percent removal is only calculated for sample pairs with influent 0.02 - 0.3 mg/L. For exception see footnote c.
^c Influent exceeded 0.3 mg/L but after discussions with Ecology on 6/5/2013, it was determined that these samples could be included for analysis.
^d Sampled flow rate is calculated by averaging the instantaneous flow rate associated with each aliquot in the composite sample.
^e Bootstrapped estimate of the upper 95% confidence limit of the mean. Only calculated for TSS effluent concentrations (not applicable to dissolved zinc).
^f Bootstrapped estimate of the lower 95% confidence limit of the mean. Used to compare to the TAPE dissolved zinc criteria of at least 60 percent removal.
Bold values met influent screening criteria and were used in performance analyses
 NA = not applicable. Percent removal results are associated with pre-filters which performed statistically worse than the cubed BioMediaGREEN. These results were not used in the final analysis.
 U = result at or below the reporting limit
 gpm = gallons/minute
 mg/L = milligram/liter

Table 12. Dissolved Copper Concentrations and Removal Efficiency Estimates for Valid Sampling Events at the AMWS Test System.

Storm Start Date & Time	Influent Conc. (mg/L)	Qualifier	Effluent Conc. (mg/L)	Qualifier	% Removal (In= 0.005-0.02) ^b	Sampled Flow Rate (gpm) ^d	Max Treated Flow Rate (gpm)	Bypass?
4/15/2012 22:45	0.0053		0.0027		49	7	16.5	
4/17/2012 21:20	0.0026		0.002	U		13	24.1	✓
4/19/2012 8:30	0.0021		0.002	U		6	12.0	✓
4/25/2012 20:50	0.011		0.0073		34	10	24.1	
5/2/2012 21:50	0.0025		0.0021			15	35.8	
5/21/2012 4:45	0.0066		0.0038		42	22	33.3	
10/14/2012 19:15	0.0057		0.0043		25	28	41.8	✓
10/15/2012 12:30	0.0049		0.0034		31	28	41.8	✓
10/28/2012 6:15	0.0016		0.0016			28	48.0	✓
10/29/2012 22:45	0.0026		0.0021			23	48.0	✓
10/31/2012 5:25	0.0018		0.0011			6	12.7	
11/23/2012 8:25	0.0012		0.0018			19	23.4	✓
11/29/2012 6:15	0.0027		0.0019			10	21.0	✓
12/2/2012 14:10	0.0032		0.0046			5	10.2	
12/3/2012 22:30	0.0024		0.0028			11	12.0	✓
12/11/2012 11:20	0.0051		0.0024		53	19	30.9	✓
12/19/2012 2:10	0.001		0.0009			17	21.0	✓
1/23/2013 12:15	0.0041	J	0.0035			6	10.2	
1/24/2013 17:50	0.0117		0.0053		54	8	25.0	✓
2/22/2013 9:30 ^a	0.0025		0.0024			40	38.6	✓
3/19/2013 15:35 ^a	0.0026		0.0022			28	31.8	✓
4/4/2013 8:00	0.034 ^a	J	0.0275		19 ^a	3	5.5	
4/6/2013 16:45	0.0144		0.0086		40	11	18.2	✓
4/10/2013 8:50	0.0205 ^a		0.0090		56 ^a	13	26.1	✓
4/18/2013 20:45	0.0225 ^a		0.0090		60 ^a	9	14.3	
4/29/2013 3:15	0.0471 ^a		0.0354		25 ^a	20	37.0	
5/16/2013 12:15 ^a	0.012		0.0093		23	50	47.6	✓
5/21/2013 11:15 ^a	0.0076		0.0056		26	28	45.6	✓
n	28		28		14			
UCL95 Mean ^e								
Mean	0.0049		0.0059		38.4			
LCL95 Mean ^f					32.5			

^a All sampled events were flow-weighted composite sampled except these events that consisted of samples collected above a high flow rate threshold.

^b Percent removal is only calculated for sample pairs with influent 0.005 - 0.02 mg/L. For exception see footnote c.

^c Influent exceeded 0.02 mg/L but after discussions with Ecology on 6/5/2013, it was determined that these samples could be included for analysis.

^d Sampled flow rate is calculated by averaging the instantaneous flow rate associated with each aliquot in the composite sample.

^e Bootstrapped estimate of the upper 95% confidence limit of the mean. Only calculated for TSS effluent concentrations.

^f Bootstrapped estimate of the lower 95% confidence limit of the mean. Used to compare to the TAPE dissolved copper criteria of at least 30 percent removal.

Bold values met Influent screening criteria and were used in performance analyses

J = estimated value based on water quality data (Appendix E)

U = result at or below the reporting limit

gpm = gallons/minute

mg/L = milligram/liter

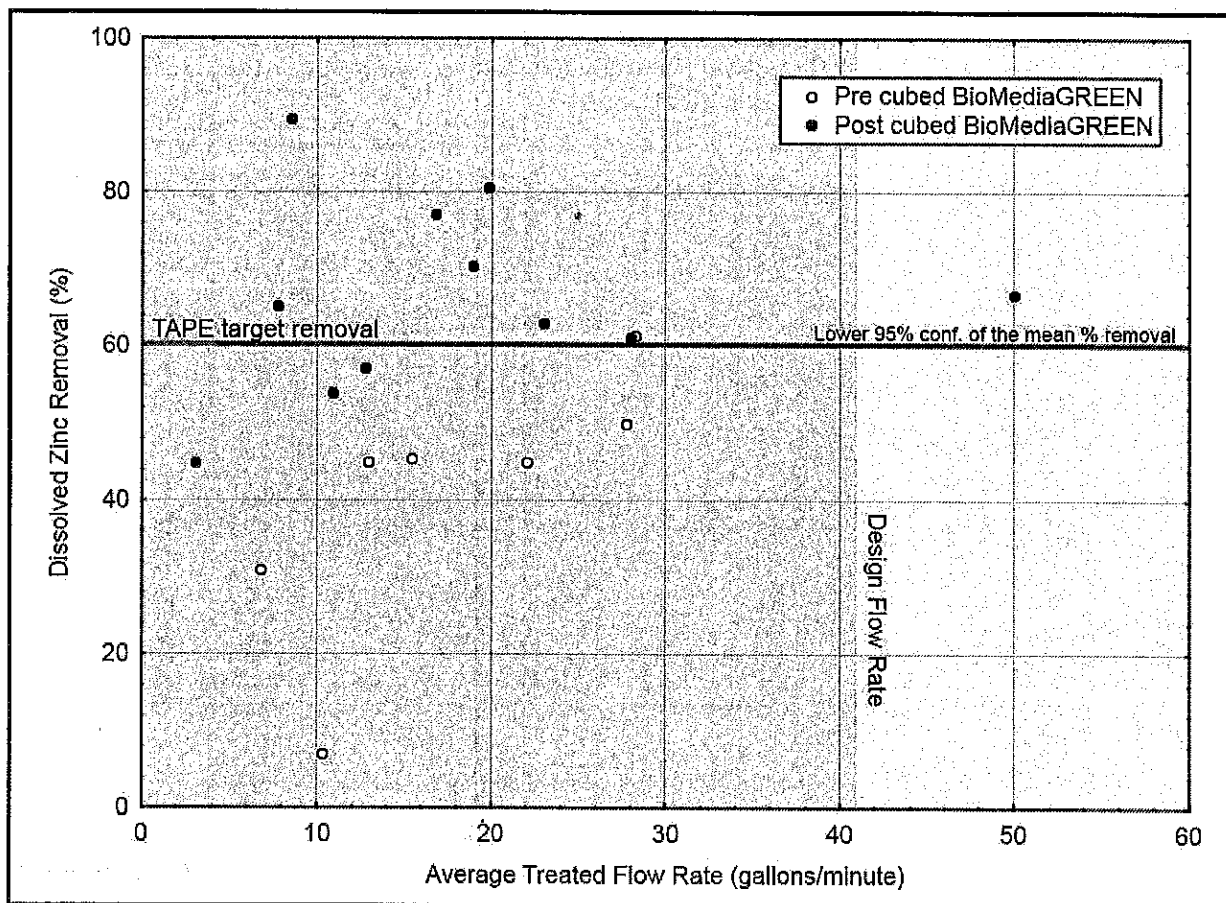

Figure 15. Dissolved Zinc Removal (%) as a Function of Average Treated Flow Rate.

To determine with flow rates were associated with dissolved copper removals, the flow rate at the point when each aliquot was collected was calculated. These flow rates were then averaged for each sampled event. As shown in Table 12, these results indicate the mean sampled treated flow rate was 17.3 gpm. As described in the *Test System Sizing* section above, the design flow rate for the system is 41 gpm. Figure 16 displays percent removal versus average treated flow rate for all of the 14 qualifying dissolved copper sample pairs (open blue circles). In addition, a data point from lab data collected in 2007 is included as a high flow rate reference point (red closed dot). The lab study data are summarized in the CULD application for the Modular Wetland System (Herrera 2011a). The TAPE indicates that lab data can be used to augment field data when determining performance at different flow rates. It should be noted that in Figure 16 it is apparent that there is no trend indicating that there is increased dissolved copper removal at lower treated flow rates. Consequently, the LCL95 mean removal of 32.5 percent is not biased by the fact that the majority of the samples were collected below the design flow rate.

The results of the regression analysis on the percent removal versus flow rate data indicated there is no significant relationship between these variables ($p = 0.079$); a visual assessment of the data in Figure 16 also show treatment above the TAPE target of 30 percent removal is evident until approximately 28 gpm. However, when the lab data point is included in the assessment, it is evident that the system (under less adverse conditions) can treat at a

much higher efficiency at the design flow rate of 41 gpm. Given this, and considering the challenging site conditions at the Albina Maintenance Facility, we propose that Ecology grant dissolved copper removal certification at 41 gpm.

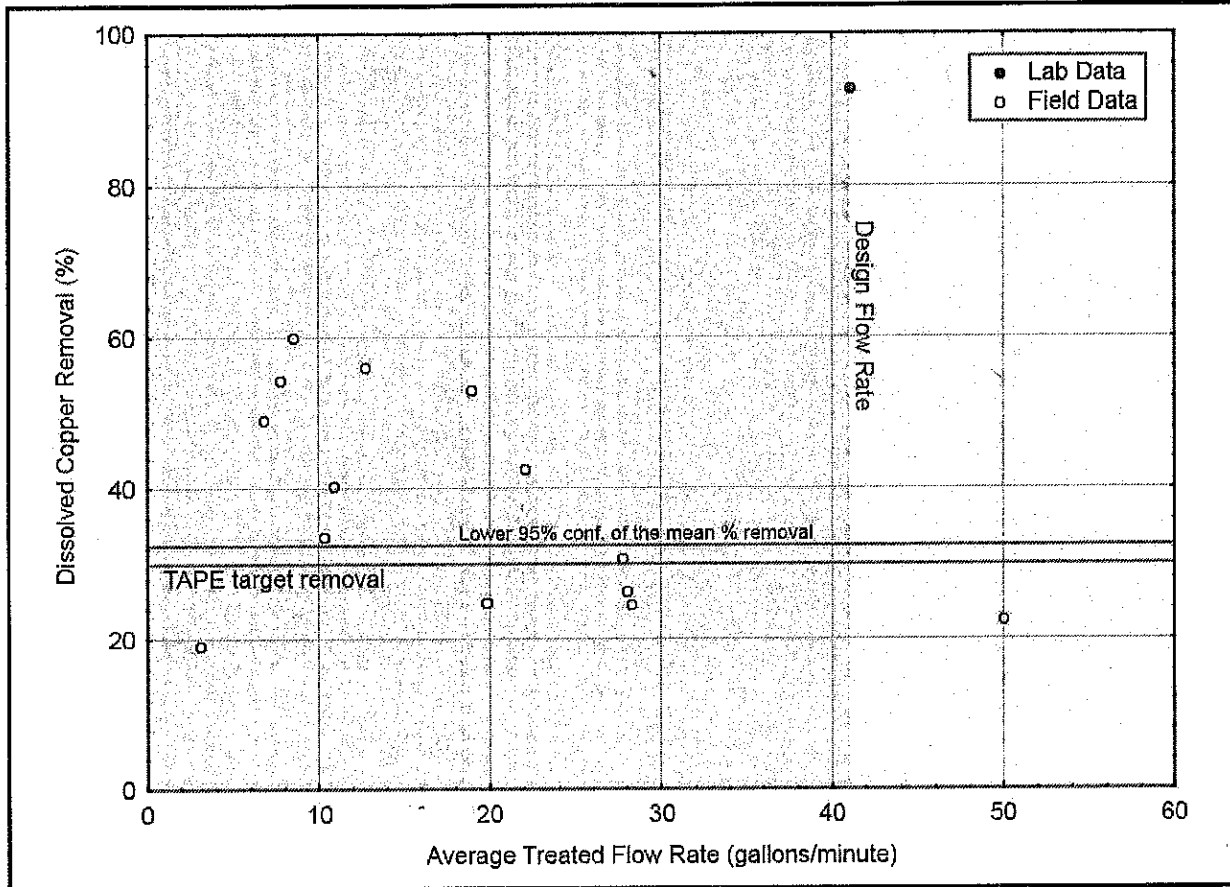

Figure 16. Dissolved Copper Removal (%) as a Function of Average Treated Flow Rate.

Taken together, the above analyses indicate that the Enhanced Treatment criteria for dissolved copper in TAPE was met. The flow rate at which dissolved copper is approved needs to be investigated further, but we propose approving dissolved copper at a flow rate of 41 gpm based on the lab data that indicates high removal at 41 gpm flow rate.

Other Parameters

The TAPE (Ecology 2011) indicates that in addition to required parameters mentioned above, screening parameters should be analyzed. The screening parameters consist of hardness, pH, and orthophosphate. The results for these parameters are presented in Table 13. The AMWS system had a negligible effect on hardness and pH. The average hardness concentrations were 37.6 and 40.6 mg CaCO₃/L at the inlet and outlet, respectively. The average pH concentrations were 7.6 and 7.5 at the inlet and outlet, respectively. TAPE guidelines indicate that the test system should not increase or decrease pH by more than one unit for any given event or export concentration less than 4 or greater than 9. The pH data presented in Table 13 indicate that these conditions were met for each sampled event.

Table 13. Summary Results for Screening Parameters.

Storm Start Date & Time	Influent Hardness (mg CaCO ₃ /L)	QA	Effluent Hardness (mg CaCO ₃ /L)	QA	Influent pH (std. units)	QA	Effluent pH (std. units)	QA	Influent ortho-P (std. units)	QA	Effluent ortho-P (std. units)	QA
4/15/2012 22:45	31		43		7.53		6.17		0.01		0.01	U
4/17/2012 21:20	37		51		7.54		7.51		0.01	U	0.01	U
4/19/2012 8:30	26		33		7.46		7.41		0.01	U	0.01	U
4/25/2012 20:50	39		48		7.51		7.54		0.069		0.024	
5/2/2012 21:50	26		31		7.4		7.29		0.016		0.01	U
5/21/2012 4:45	37		44		7.48		7.45		0.047		0.013	
10/14/2012 19:15	30		48		7.13		6.82		0.073		0.05	U
10/15/2012 12:30	35		42		7.3		7.2		0.059		0.08	
10/28/2012 6:15	29		31		7.57		7.45		0.05	H	0.05	UH
10/29/2012 22:45	35		35		7.41		7.36		0.05	U	0.05	U
10/31/2012 5:25	45		46		7.52		7.56		0.05	U	0.05	U
11/23/2012 8:25					7.29	J	7.41	J				
11/29/2012 6:15	33.2		30.4		7.74		7.32		0.05	U	0.05	U
12/2/2012 14:10	29.2		30		7.15		7.19		0.05	U	0.05	U
12/3/2012 22:30									0.05	U	0.05	U
12/11/2012 11:20	27.2		29.6		7.88	J	7.92	J	0.05	U	0.05	U
12/19/2012 2:10	19.6		25.2		7.86		7.71		0.05	U	0.05	U
1/23/2013 12:15	40		41.2		8.06		7.72		0.05	U	0.05	U
1/24/2013 17:50	38		34.8		7.71		7.81		0.05	U	0.05	U
2/22/2013 9:30 ^a	62.8		50.8		8.84		8.14		0.05	U	0.05	U
3/19/2013 15:35 ^a	36.8		39.2		7.86		7.77		0.05	U	0.05	U

April 2014

Table 13 (continued). Summary Results for Screening Parameters.

Storm Start Date & Time	Influent Hardness (mg CaCO ₃ /L)	QA	Effluent Hardness (mg CaCO ₃ /L)	QA	Influent pH (std. units)	QA	Effluent pH (std. units)	QA	Influent ortho-P (std. units)	QA	Effluent ortho-P (std. units)	QA
4/4/2013 8:00	76		58.8		7.09	J	7.69	J	0.96		0.199	
4/6/2013 16:45	36		38.4		7.67		6.96		0.123		0.05	U
4/10/2013 8:50	43.2		41.6		7.83		8.13		0.426		0.05	U
4/18/2013 20:45	48		47.2		7.66		7.69		0.06		0.05	U
4/29/2013 3:15	42.4		47.6		7.33		7.52		0.156		0.05	U
5/16/2013 12:15 ^a	47.2		53.2		7.32		7.41		0.114		0.05	U
5/21/2013 11:15 ^a	28.4		34.4		7.65	J	7.57	J	0.062		0.05	U
Minimum	19.6		25.2		7.09		6.17		0.01		0.01	U
Mean	37.6		40.6		7.6		7.5		0.093		0.031	
Maximum	76		58.8		8.84		8.14		0.960		0.199	

^a All sampled events were flow-weighted composite sampled except these events, which consisted of samples collected above a high flow rate threshold.

Ortho-P = Orthophosphorus

J = estimated value based on water quality data (Appendix E)

QA = quality assurance

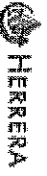

The orthophosphorus data indicated that the AMWS system reduced orthophosphorus by 67 percent, on average. When compared with other treatment systems (Herrera 2006, 2009, 2010, 2011c), the AMWS exhibited a substantially higher orthophosphorus removal rate.

CONCLUSIONS

To obtain performance data to support the issuance of a GULD for the Modular Wetland System - Linear stormwater filtration system, Herrera conducted hydrologic and water quality monitoring at a test system in Portland, Oregon from April 14, 2012, to May 31, 2013. During this monitoring period, 28 separate storm events were sampled.

Of the 28 sampled events, 24 qualified for total suspended solids analysis. The data were segregated into sample pairs with influent concentration greater than and less than 100 mg/L. The UCL95 mean effluent concentration for the data with influent less than 100 mg/L was 12.8 mg/L, below the 20 mg/L threshold. In addition, the system exhibited TSS removal greater than 80 percent at flow rates up to and including the design flow rate of 41 gpm. Based on these results we recommend the system be granted Basic Treatment certification at 50 gpm (equivalent to 1.21 gpm/ft² of media).

Nineteen of the 28 sampled events qualified for total phosphorus analysis. The LCL95 mean percent removal was 61.7, well above the TAPE goal of 50 percent. Treatment above 50 percent was evident at flow rates up to and including the design flow rate of 41 gpm. Based on these results we recommend the system be granted Phosphorus Treatment certification at 50 gpm (equivalent to 1.21 gpm/ft² of media).

Eleven of the 28 sampled events qualified for assessment for dissolved zinc removal. The LCL95 mean removal was 60.5 percent while the TAPE goal is greater than 60 percent removal. Treatment above 60 percent was evident at flow rates up to and including the design flow rate of 41 gpm. Consequently, the MWS-Linear met the Enhanced Treatment criterion specified for dissolved zinc in TAPE at the design flow rate.

Fourteen of the 28 sampled events qualified for assessment for dissolved copper removal. The LCL95 mean removal was 32.5 percent while the TAPE goal is greater than 30 percent removal. Treatment above 30 percent was evident at flow rates up to 28 gpm. When lab data are used to augment the dataset, the results indicate the MWS-Linear met the Enhanced Treatment criterion specified for dissolved copper in TAPE at flow rates up to and including the design flow rate of 41 gpm.

REFERENCES

- APHA, AWWA, and WEF. 1992. Standard Methods for the Examination of Water and Wastewater. 18th edition. Edited by A. Greenberg, A.D. Eaton, and L. Clesceri. American Public Health Association, American Water Works Association, Water Environment Federation, Washington, D.C.
- APHA, AWWA, and WEF. 1998. Standard Methods for the Examination of Water and Wastewater. 20th edition. Edited by A. Greenberg, A.D. Eaton, and L. Clesceri. American Public Health Association, American Water Works Association, Water Environment Federation, Washington, D.C.
- Davison, A.C. and D.V. Hinkley. 1997. Bootstrap Methods and Their Application. Cambridge University Press, Cambridge; New York.
- Ecology. 2004. Stormwater Management Manual for Eastern Washington. Washington State Department of Ecology, Olympia, Washington.
- Ecology. 2011. Technical Guidance for Evaluating Emerging Stormwater Treatment Technologies: Technology Assessment Protocol - Ecology (Tape). Publication No. 11-10-061, Washington State Department of Ecology, Olympia, Washington.
- Ecology. 2012. 2012 Stormwater Management Manual for Western Washington: Volume III - Hydrologic Analysis and Flow Control Design/BMPs. Washington State Department of Ecology, Olympia, Washington.
- Helsel, D.R. and R.M. Hirsch. 2002. Statistical Methods in Water Resources. Elsevier, Amsterdam.
- Herrera. 2006. Technology Evaluation and Engineering Report: WSDOT Ecology Embankment. Prepared for Washington Department of Transportation by Herrera Environmental Consultants, Inc., Seattle, Washington.
- Herrera. 2009. Technical Evaluation Report: Filterra Bioretention Filtration System Performance Monitoring. Prepared for Americast, Inc., by Herrera Environmental Consultants, Inc., Seattle, Washington.
- Herrera. 2010. Technical Evaluation Report: Kristar Perk Filter Stormwater Treatment System Performance Monitoring. Prepared for KriStar Enterprises, Inc., by Herrera Environmental Consultants, Inc., Seattle, Washington.
- Herrera. 2011a. Application for Conditional Use Level Designation: Modular Wetland System - Linear Stormwater Filtration System. Prepared for Modular Wetland Systems, Inc., by Herrera Environmental Consultants, Inc., Seattle, Washington.

Herrera. 2011b. Quality Assurance Project Plan: Modular Wetland System - Linear Treatment System Performance Monitoring Project. Prepared for Modular Wetland Systems, Inc., by Herrera Environmental Consultants, Inc., Seattle, Washington.

Herrera. 2011c. Technical Evaluation Report: Compost-Amended Biofiltration Swale Evaluation. Prepared for Washington Department of Transportation, by Herrera Environmental Consultants, Inc., Seattle, Washington.

Means, J. and R. Hinchee. 1994. Emerging Technology for Bioremediation of Metals. Battelle, Columbus, Ohio.

Reeves, R.D. and A.J.M. Baker. 2000. Metal-Accumulating Plants. In: I. Raskin and B. Ensley (Editors), Phytoremediation of Toxic Metals. John Wiley & Sons, New York, New York. pp. 193-230.

US EPA. 1983. Methods for Chemical Analysis of Water and Wastes. EPA 600/4-79-020, US Environmental Protection Agency, Environmental Monitoring and Support Laboratory, Washington, D.C.

US EPA. 1984. Guidelines Establishing Test Procedures for the Analysis of Pollutants under the Clean Water Act; Final Rule and Interim Final Rule. CFR Part 136. US Environmental Protection Agency, Washington, D.C.

Walkowiak, D.K. (Editor), 2006, Isco Open Channel Flow Measurement Handbook. Teledyne Isco, Inc., Lincoln, Nebraska. 520 pp.