

June 9, 2021

Mr. Leo Cosentini
California State Water Resources Control Board
Division of Water Quality
P.O. Box 100
Sacramento, CA 95812-0100

RE: Former Product Name: Flo Guard + Plus® Catchbasin Trash Screen Insert, Flat Grated
Inlet Style Drop in Basket (KS-2)

Dear Mr. Cosentini,

Oldcastle Infrastructure™ is pleased to submit this updated fact sheet. The enclosed updated fact sheet has been compiled in conformance with the Trash Treatment Control Device Application Requirements. This updated fact sheet is replacing the GIB updated fact sheet submitted January 26, 2021 (superseded due to manufacturing requirements). As the previous updated fact sheet was never completed, we sincerely appreciate your attention to make the following changes from the original fact sheet:

- Update Name: FloGard® Grate Inlet Basket (GIB)
- Remove “formerly KriStar Enterprises Inc.” (acquisition was 2014, pre-trash requirements; systems have been updated; KriStar reference confuses customers)
- Fact Sheet: Change from KS-2 to OI-2

Thank you for your consideration of this application. If any additional information is needed, please contact Laraine Sanfilippo per information provided below.

Respectfully,

Oldcastle Infrastructure™, A CRH Company



Laraine Sanfilippo
Southwest Region Regulatory Manager
laraine.sanfilippo@oldcastle.com
(619) 481-0608

1. Cover Letter

a. Product Name and General Description of Device

The FloGard® Grate Inlet Basket (FloGard® GIB) is a specialized inlet filter used specifically for grated catch basins. The FloGard® GIB provides physical screening of pollutants such as gross solids, trash and debris. It is ideally suited for removal of primary pollutants from paved surfaces in commercial and residential areas.

b. Applicant's Contact Information and Location

Chief Executive Officer: Matt Clemson
Oldcastle Infrastructure™
Vice President and General Manager, Stormwater
matt.clemson@oldcastle.com
(470) 261-7620

Authorized Representative: Laraine Sanfilippo
Oldcastle Infrastructure™
Regulatory Manager
laraine.sanfilippo@oldcastle.com
(619) 481-0608

Mailing Address: Oldcastle Infrastructure, Stormwater
c/o Laraine Sanfilippo
10441 Vine Street
Lakeside, CA 92040

c. Manufacturer's Website for Device

<https://oldcastleinfrastructure.com/brands/flogard/>

d. Manufacturing Location for Device

Manufacturer Name: Oldcastle Infrastructure™
Manufacturer Address: 7100 Longe Street
Stockton, CA 95304
Manufacturer Phone: (800) 579-8819
Manufacturer Representative: Gary Jones
(888) 950-8826

e. Summary of Field/Lab Testing Results

All trash and debris for the designed storm event is captured within the FloGard® GIB due to the basket's full capture 4.9mm perforations. No lab testing has been recorded for the FloGard® GIB.

f. Summary of Device Limitations, and Operational, Sizing, and Maintenance Considerations

FloGard® GIB is designed for ease of use and compatibility with most catch basin configurations. Standard sizes are available and custom units will be considered as unusual or challenging projects arise. Please contact an Oldcastle Infrastructure™ representative for sizing assistance.

Maintenance on any stormwater management device is mandatory. The schedule of maintenance will depend on site conditions and should be determined during the first year of operation by assessing capacity levels after large storm events. Consistent maintenance is imperative to ensure constant trash capture is attained and bypass does not occur.

g. Description, or List of Locations, where Device has been installed

FloGard® GIB has been installed throughout California and nationally to meet trash capture demands. See chart below for a few example installations:

Example Installations*		
Project	Location	Contact
City of Berkely Police Department	2100 Martin Luther King Jr Way Berkeley, CA 94704	Environmental Compliance Specialist Lam Inthavong
City of Santa Clara Transportation Authority	3331 North First Street San Jose, CA 95134	Facilities Maintenance Manager Valley Transit Authority
In-N-Out Burger California	28 Locations throughout California	Facilities Management Patty Olivares

*Please contact an Oldcastle Infrastructure™ representative for more detailed information.

h. Certification

I certify under penalty of law that this document and all attachments were prepared under my direction or supervision in accordance with a system designed to assure that qualified personnel properly gather and evaluate the information submitted. Based on my inquiry of the person or persons that manage the system or those persons directly responsible for gathering the information, to the best of my knowledge and belief, the information submitted is, true, accurate, and complete. I am aware that there are significant penalties for submitting false information, including the possibility of fine and imprisonment for knowing violations.



Matt Clemson
Oldcastle Infrastructure™
General Manager, Stormwater
matt.clemson@oldcastle.com
(470) 261-7620

5/18/2021

Date



Laraine Sanfilippo
Oldcastle Infrastructure™
Regulatory Manager
laraine.sanfilippo@oldcastle.com
(619) 481-0608

5/18/2021

Date

Table of Contents

1. Cover Letter	i
a. Product Name and General Description of Device	i
b. Applicant’s Contact Information and Location	i
c. Manufacturer’s Website for Device	i
d. Manufacturing Location for Device	ii
e. Summary of Field/Lab Testing Results	ii
f. Summary of Device Limitations, and Operational, Sizing, and Maintenance Considerations	ii
g. Description, or List of Locations, where Device has been installed	ii
h. Certification	iii
2. Table of Contents	1
3. Physical Description	2
a. Trash Capture: Description of Device	2
b. Peak Flows/ Trash Volumes	2
c. Hydraulic Capacity	2
1) Hydraulic Capacity Table	2
2) Alternative Configuration Hydraulic Capacity Table	2
3) Hydraulic Capacity Calculations or Field Test Results	3
d. Comparison Table	3
e. Design Drawings	3
f. Alternative Configurations	3
g. Internal Bypass	3
h. Previously Trapped Trash	3
i. Calibration Feature	3
j. Photos	4
k. Material Type	5
l. Design Life	5
4. Installation Guidance	6
a. Installation Procedures	6
b. Device Installation Limitations/ Non-standard Installation Procedures	6
c. Diagnosing and Correcting Installation Errors	6

5. Operation and Maintenance Information	7
a. Device Inspection Procedures and Frequency Considerations.....	7
b. Device Maintenance Frequency Related to Hydraulic Capacity.....	7
c. Maintenance Procedures.....	7
d. Maintenance Equipment and Materials.....	8
e. Effects of Deferred Maintenance.....	8
f. Repair Procedures.....	8
6. Vector Control Accessibility	9
a. Date of Submittal to Mosquito Vector Control Association.....	9
b. Description of Access for Vector Control Personnel.....	9
c. Letter of Verification from Mosquito Vector Control Association.....	9
7. Reliability Information	10
a. Estimated Design Life.....	10
b. Warranty Information.....	10
c. Customer Support Information.....	10
8. Field/Lab Testing Information and Analysis	11
a. Available Field/Lab Testing Information – Devices with 5mm Screen.....	11
b. Available Field/Lab Testing Information – Devices without 5mm Screen.....	11
APPENDIX A	12
Hydraulic Capacity Calculations.....	13
APPENDIX B	16
Design Drawings.....	17
APPENDIX C	18
MVCAC Approval Document.....	19

3. Physical Description

a. Trash Capture: Description of Device

FloGard® GIB is configured with openings less than 4.9mm to ensure trash capture regulations and requirements are met. The system location in the catch basin ensures all flows discharging from the stormwater system will be treated. The FloGard® GIB sizing is dependent on catch basin dimensions with bypass flows accounted for on all required designs.

b. Peak Flows/ Trash Volumes

The tables in **Section 3c.1. Hydraulic Capacities** list Peak Flow and Trash (Storage) Volume capacities for 8 standard sizes of the FloGard® GIB.

c. Hydraulic Capacity

1) Hydraulic Capacity Table

FloGard® Grate Inlet Basket - Capacities*						
Catch Basin Size	Hydraulic Capacity					Storage Capacity (CF)
	Filtered Flow (CFS)				Peak/ Bypass Flow (CFS)	
	Empty	25% Full	50% Full	75% Full		
12x12	5.75	4.31	2.88	1.44	1.21	0.75
16x16	7.95	5.97	3.98	1.99	1.61	1.33
18x18	9.11	6.83	4.55	2.28	1.81	1.69
18x36	14.38	10.79	7.19	3.60	2.71	3.38
24x24	12.78	9.59	6.39	3.20	2.41	3.00
24x36	16.62	12.47	8.31	4.16	3.01	4.50
36x36**	28.77	21.57	14.38	7.19	5.42	6.75
36x48**	33.24	24.93	16.62	8.31	6.03	9.00

Notes:

* Additional sizes available per region and request. Please speak with an Oldcastle Infrastructure representative for more detailed information.

** Systems noted are comprised of (2) FloGard® GIBs in parallel

2) Alternative Configuration Hydraulic Capacity Table

FloGard® GIB does not have alternative configurations.

3) Hydraulic Capacity Calculations or Field Test Results

Hydraulic capacity calculations for FloGard® GIB are included in **Appendix A**.

d. Comparison Table

The tables in **Section 3c.1. Hydraulic Capacities** list storage and hydraulic capacities for 8 standard sizes of the FloGard® GIB.

e. Design Drawings

Design drawings for FloGard® GIB are included in **Appendix B**.

f. Alternative Configurations

FloGard® GIB does not have alternative configurations.

g. Internal Bypass

Bypass is designed to occur in situations that 100% storage capacity has been met (which should be avoided through regular inspection and maintenance). In situations where bypass occurs, FloGard® GIB is designed to hydraulically contain the previously captured trash and allow flows to enter and exit the system at the center of the basket.

h. Previously Trapped Trash

The basket is hydraulically designed to retain previously captured trash. If the system achieves bypass, some previously captured trash may reanimate and discharge downstream; however, the design is meant to prevent this occurrence. So long as the system is regularly maintained and bypass is avoided, no previously trapped trash will discharge from the system.

i. Calibration Feature

FloGard® GIB does not include an adjustable calibration feature.

j. Photos

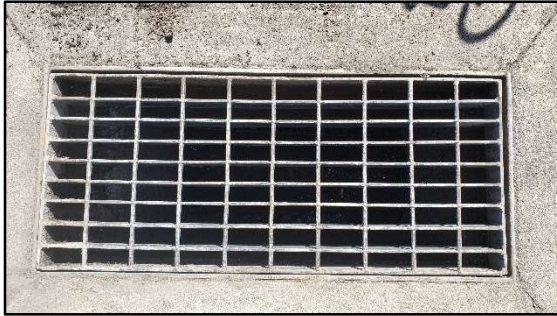

Figure 1. Pre-Installation Grate Inlet.



Figure 2. Installed FloGard® GIB without grate.



Figure 3. Installed FloGard® GIB with grate.

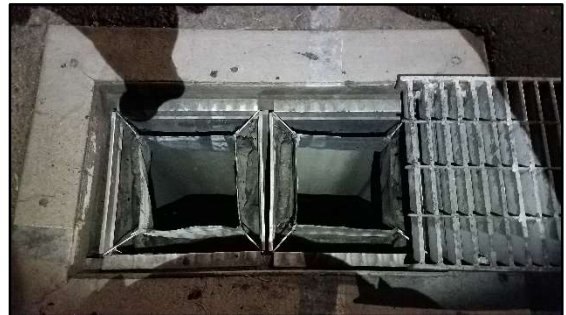

Figure 4. Installed FloGard® GIB – parallel systems.



Figure 5. Installed FloGard® GIB – view to bottom.



Figure 6. Installed FloGard® GIB – view to bottom: water.

k. Material Type

The FloGard® GIB system consists of mounting angles and basket with trash capture compliant screen. The mounting angles and basket frame are 304 stainless-steel. The basket is flexible knit nylon mesh backed by reinforced polypropylene geogrid. The screen perforations measure 4.9mm for trash capture compliance.

l. Design Life

The estimated design life for the FloGard® GIB is 25 years. Design life estimate is dependent on the proper design, installation and maintenance of the system and assume no extraordinary circumstances.

4. Installation Guidance

a. Installation Procedures

Oldcastle Infrastructure™ recommends referring to approved drawings and field measurements to ensure site conditions are properly met prior to installation. It is recommended that catch basins are properly cleaned and inspected for any damage or irregularities prior to installing any devices. If installation points on walls are irregular or damaged, grind the concrete down to create an even mounting surface.

1. Remove grate cover and set aside.
2. Clean catch basin frame and FloGard® GIB support flanges.
3. Place FloGard® GIB into catch basin frame so that support flanges are held up on all ends by the extents of the catch basin frame.
 - a. If flanges are not supported on all sides by the catch basin frame, remove and call an Oldcastle Infrastructure™ representative for sizing/customization guidance.
4. Replace grate.

b. Device Installation Limitations/ Non-standard Installation Procedures

Installation to help meet trash TMDLs or the statewide trash amendment are often retrofit. In the case of retrofit, the site should be inspected prior to installation to be sure record drawings are correct. The trash capture system should be designed and fabricated to meet existing site conditions.

c. Diagnosing and Correcting Installation Errors

Oldcastle Infrastructure™ FloGard® GIB is designed for simple installation. Once installed, ensure a proper fit by performing a visual inspection. If all components are not secure and in proper placement, remove and reinstall by following **Section 4a. Installation Procedures**. If questions during or after installation, please contact Oldcastle Infrastructure™ for project specific assistance.

5. Operation and Maintenance Information

a. Device Inspection Procedures and Frequency Considerations

Oldcastle Infrastructure™ recommends the following timing of inspections to ensure proper maintenance can be conducted:

Oldcastle Infrastructure™ recommends that installed FloGard® GIB be serviced on a recurring basis. Ultimately, the frequency depends on the amount of runoff, pollutant loading and interference from debris (leaves, vegetation, cans, paper, etc.); however, it is recommended that each installation be inspected a minimum of three times per year.

Oldcastle Infrastructure™ guidelines for the timing of inspections are as follows:

1. For areas with a definite rainy season: Prior to, during and following the rainy season.
2. For areas subject to year-round rainfall: On a recurring basis (at least three times per year).
3. For areas with winter snow and summer rain: Prior to and just after the snow season and during the summer rain season.
4. For installed devices not subject to the elements (washracks, parking garages, etc.): On a recurring basis (no less than three times per year).

b. Device Maintenance Frequency Related to Hydraulic Capacity

Due to the configuration of FloGard® GIB, maintenance does not rely on hydraulic capacity, but rather on storage (trash and debris) capacity. Maintenance should be implemented between storm events if basket is at more than 75% capacity. Maintenance must be implemented immediately if basket is at 100% capacity and in bypass.

c. Maintenance Procedures

Oldcastle Infrastructure™ recommends the following maintenance procedures:

1. The grate shall be removed and set to one side. The catch basin shall be visually inspected for defects and possible illegal dumping. If illegal dumping has occurred, the proper authorities and property owner representative shall be notified as soon as practicable.
2. Using an industrial vacuum, the collected materials shall be removed from the basket.
3. When all collected materials have been removed, the basket can be inspected for continued serviceability. Minor damage or defects found shall be corrected on-the-spot and a notation made on the Maintenance Record. More extensive deficiencies that cannot be fixed on-site should be addressed through a maintenance service or by replacement of parts.

4. After inspection is complete and system is certified as functional, replace grate.
5. All removed debris shall be disposed of in accordance with local, state, and federal agency requirements.

d. Maintenance Equipment and Materials

The following equipment should be used to conduct maintenance on the FloGard® GIB:

- Personal Protective Equipment (PPE)
 - i.e. hardhat, gloves, appropriate footwear, safety glasses, etc.
- Industrial vacuum
- Dumpster or truck bed for disposal of collected trash and debris
- Tools for uninstallation and reinstallation
 - Crow bar to help remove grate from catch basin
 - File or wire brush to clean frame of catch basin and FloGard® GIB

e. Effects of Deferred Maintenance

Deferred maintenance may allow the FloGard® GIB to achieve capacity and go into bypass. Once the system is in bypass, no additional trash or debris will be collected. If bypass occurs, the debris in the bypass flows will pass through the system and discharge in receiving waters.

f. Repair Procedures

If inspection of the condition of the FloGard® GIB reveals damage and need for repair, the damage should be documented, photographed, and then submitted to Oldcastle Infrastructure™ for assessment. Engineering and Operations staff at Oldcastle Infrastructure™ will evaluate the damage and recommend a repair. Responsibility for the repair will depend on the cause of damage.

Field repairs can be implemented if issues or damage is minimal.

If inspection of the condition of the FloGard® GIB (basket) reveals extensive damage that cannot be repaired in field, a replacement basket will need to be installed to ensure proper trash capture capacity is attained.

6. Vector Control Accessibility

a. Date of Submittal to Mosquito Vector Control Association

Application for approval of the FloGard® GIB was initially submitted to the Mosquito and Vector Control Association of California (MVCAC) on May 18, 2021. This submittal was made concurrently with the original California Water Boards Trash Treatment Control Device Updated Fact Sheet submittal.

b. Description of Access for Vector Control Personnel



The bottom of the catch basin (includes any area beneath the basket) can be easily accessed through the grate. The grate can be opened/removed for visual inspection and physical treatment of the catch basin. Due to the location of the basket within the catch basin, complete access is available to the entire bottom of catch basin, the inside of the basket, and the entrance to all outlet pipes within the basin for both inspection and treatment. It is also possible to inspect and treat through the grate depending on the spacing of the bars and type of treatment required.

Letter of Verification from Mosquito Vector Control Association

Refer to Appendix C for letter of verification from MVCAC, Mosquito and Vector Control Association of California, dated June 9, 2021. Approval letter verifies all design requirements have been met and allow for full visual and treatment access to all areas.

7. Reliability Information

a. Estimated Design Life

The estimated design life for the FloGard® GIB is 25 years. Design life estimate is dependent on the proper design, installation and maintenance of the system and assume no extraordinary circumstances.

b. Warranty Information

Oldcastle Infrastructure™ warrants FloGard® GIB to be free from manufacturing defects for a period of one (1) year from the date of purchase. Abusive treatment, neglect or improper use of the FloGard® GIB will not be covered by this warranty.

c. Customer Support Information

Oldcastle Infrastructure offers full customer support for all products including the FloGard® GIB. Customer Support contact information is as follows:

Oldcastle Infrastructure™
7100 Longe Street
Stockton, CA 95304
Phone: (888) 965-3227
Website: www.oldcastleinfrastructure.com
Email Contact: ContactInfrastructure@Oldcastle.com

8. Field/Lab Testing Information and Analysis

a. Available Field/Lab Testing Information – Devices with 5mm Screen

The FloGard® GIB includes a screen with 4.9mm apertures through which all treatment flow must pass to travel downstream; therefore, testing is not required to demonstrate trash capture performance because particles 5mm in diameter and larger cannot physically pass through the screen.

b. Available Field/Lab Testing Information – Devices without 5mm Screen

FloGard® GIB systems without the trash capture (4.9mm aperture) screen do not have testing or field data available and will not be used for trash capture applications.

APPENDIX A

Technical Memorandum

FloGard® GIB

Hydraulic Capacity Calculations

This technical memorandum documents the hydraulic calculations for the FloGard® GIB.

I. Standard Equations

Filtered and Bypass Flow Capacity

- Orifice Equation for Screen Basket; $Q_f = \frac{C A_s \sqrt{2 g h}}{SF}$
 - Q_f = Treatment Flow Rate; ft³/sec
 - C = Discharge (Orifice) Coefficient; 0.85
 - A_{screen} = (Surface Area) * (% Open); ft²
 - $A_{square} = 4(DW) + 4(DL) + WL_{ext} - WL_{int}$
 - $A_{rectangle} = 2(DL)_{ext} + 2(DW)_{ext} + 2(DL)_{int} + 2(DW)_{int} + WL_{ext} - WL_{int}$
 - $A_{bypass} = (H_{bypass})(2L_{int} + 2W_{int})$
 - g = Gravity; 32.174 ft/sec²
 - h = Available (Driving) Head; ft
 - Filtered Flow = 0.25 ft
 - Bypass Flow = 0.5 ft
 - SF = Safety Factor; 2

- Storage Volume for Screen Basket; $V_s = WLD_{ext} - WLD_{int}$
 - V_s = Storage Volume; ft³
 - W = Basket Width; ft
 - L = Basket Length; ft
 - D = Basket Depth; ft

II. Example Calculations

Filtered Flow Calculation; 12" x 12" Grate Inlet

- $A_{\text{square}} = 4(DW) + 4(DL_{\text{int}}) + WL_{\text{ext}} - WL_{\text{int}}$
 - $W = \frac{12 \text{ in}}{12 \text{ in}} = 1.00 \text{ ft}$
 - $L_{\text{ext}} = \frac{12 \text{ in}}{12 \text{ in}} = 1.00 \text{ ft}$
 - $L_{\text{int}} = \frac{6 \text{ in}}{12 \text{ in}} = 0.50 \text{ ft}$
 - $D = \frac{12 \text{ in}}{12 \text{ in}} = 1.00 \text{ ft}$
 - $A_{\text{square}} = (4)(1.00 \text{ ft})(1.00 \text{ ft}) + (4)(1.00 \text{ ft})(0.50 \text{ ft}) + (1.00)(1.00 \text{ ft}) - (0.50 \text{ ft})(0.50 \text{ ft}) = 6.75 \text{ ft}^2$
- $A_{\text{screen}} = (\text{Surface Area, } A_{\text{square}}) * (\% \text{ Open})$
 - $A_{\text{screen}} = 6.75 \text{ ft}^2 * 50\% = 3.375 \text{ ft}^2$
- $Q_f = \frac{C A_s \sqrt{2 g h}}{SF}$
 - $C = 0.85; A_{\text{screen}} = 3.375 \text{ ft}^2; g = 32.174 \text{ ft/s}^2; h = 0.25 \text{ ft}; SF = 2$
 - $Q_f = \frac{0.85 * 3.375 \sqrt{2 * 32.174 * 0.25}}{2}$
 - $Q_f = 5.75 \text{ ft}^3/\text{sec}$

Filtered Flow at 100% capacity is 5.75 cfs.

Bypass Flow Calculation; 12" x 12" Grate Inlet

- $A_{\text{bypass}} = (H_{\text{bypass}})(2L_{\text{int}} + 2W_{\text{int}})$
 - $H_{\text{bypass}} = \frac{3 \text{ in}}{12 \text{ in}} = 0.25 \text{ ft}$
 - $L_{\text{int}} = \frac{6 \text{ in}}{12 \text{ in}} = 1.50 \text{ ft}$
 - $W_{\text{int}} = \frac{6 \text{ in}}{12 \text{ in}} = 1.50 \text{ ft}$
 - $A_x = (0.25 \text{ ft})(2)(0.50 \text{ ft}) + (2)(0.50 \text{ ft}) = 0.50 \text{ ft}^2$
- $Q_b = \frac{C A_s \sqrt{2 g h}}{SF}$
 - $C = 0.85; A_s = 0.50 \text{ ft}^2; g = 32.174 \text{ ft/s}^2; h = 0.50 \text{ ft}; SF = 2$
 - $Q_b = \frac{0.85 * 0.50 \sqrt{2 * 32.174 * 0.50}}{2}$
 - $Q_b = 1.21 \text{ ft}^3/\text{sec}$

Bypass Flow is 1.21 cfs.

Storage Capacity Calculation; 12" x 12" Grate Inlet

- Storage Volume for Screen Basket; $V_s = (WLD)_{\text{ext}} - (WLD)_{\text{int}}$
 - $W_{\text{ext}} = \frac{12 \text{ in}}{12 \text{ in}} = 1.00 \text{ ft}$
 - $W_{\text{int}} = \frac{6 \text{ in}}{12 \text{ in}} = 0.50 \text{ ft}$
 - $L_{\text{ext}} = \frac{12 \text{ in}}{12 \text{ in}} = 1.00 \text{ ft}$
 - $L_{\text{int}} = \frac{6 \text{ in}}{12 \text{ in}} = 0.50 \text{ ft}$
 - $D_{\text{ext}} = \frac{12 \text{ in}}{12 \text{ in}} = 1.00 \text{ ft}$
 - $D_{\text{int}} = \frac{12 \text{ in}}{12 \text{ in}} = 1.00 \text{ ft}$
 - $V_s = ((1.00 \text{ ft})(1.00 \text{ ft})(1.00 \text{ ft})) - ((0.50 \text{ ft})(0.50 \text{ ft})(1.00 \text{ ft})) = 0.75 \text{ ft}^3$

Storage Capacity is 0.75 cf.

APPENDIX B

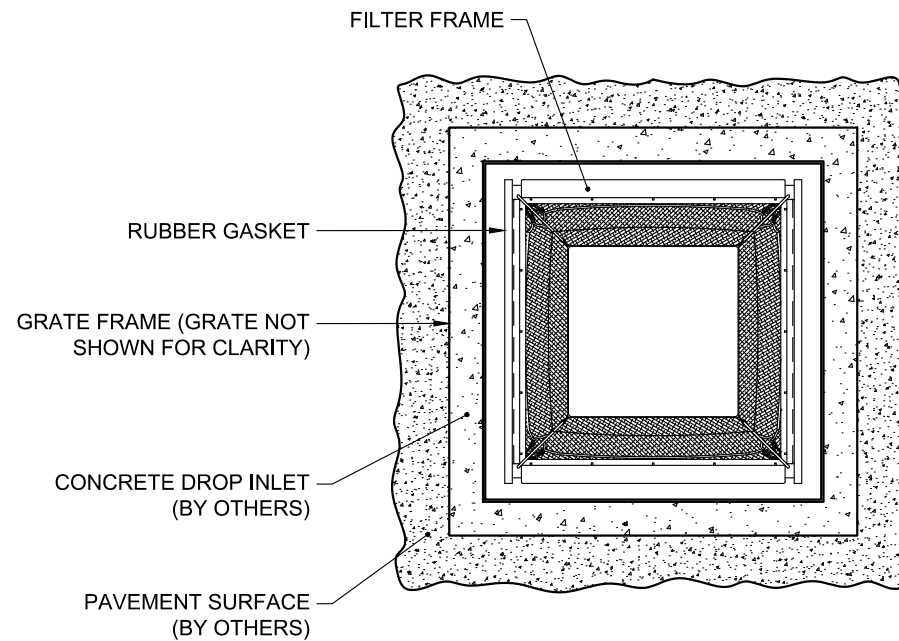
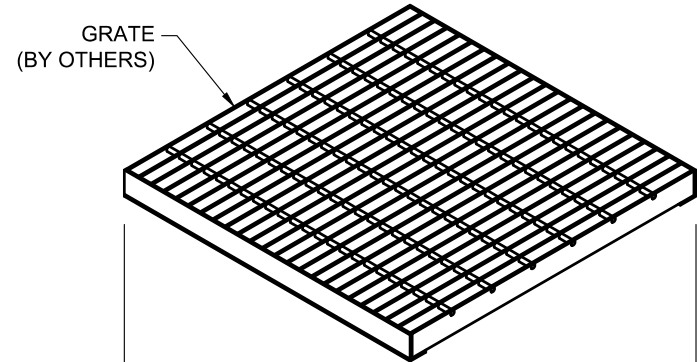

PLAN VIEW
(GRATE NOT SHOWN FOR CLARITY)

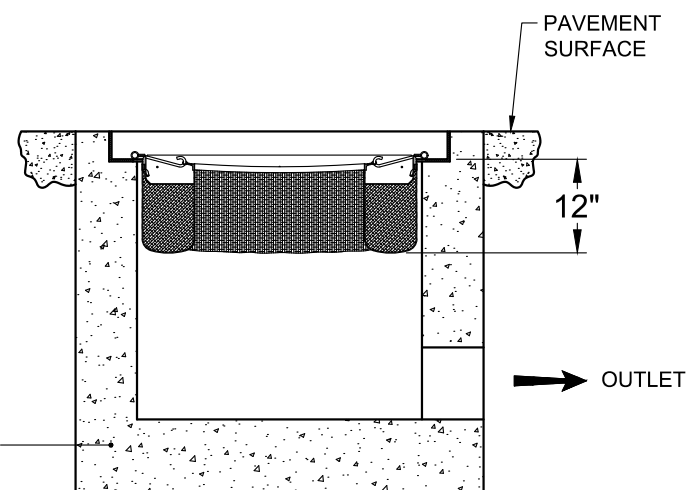
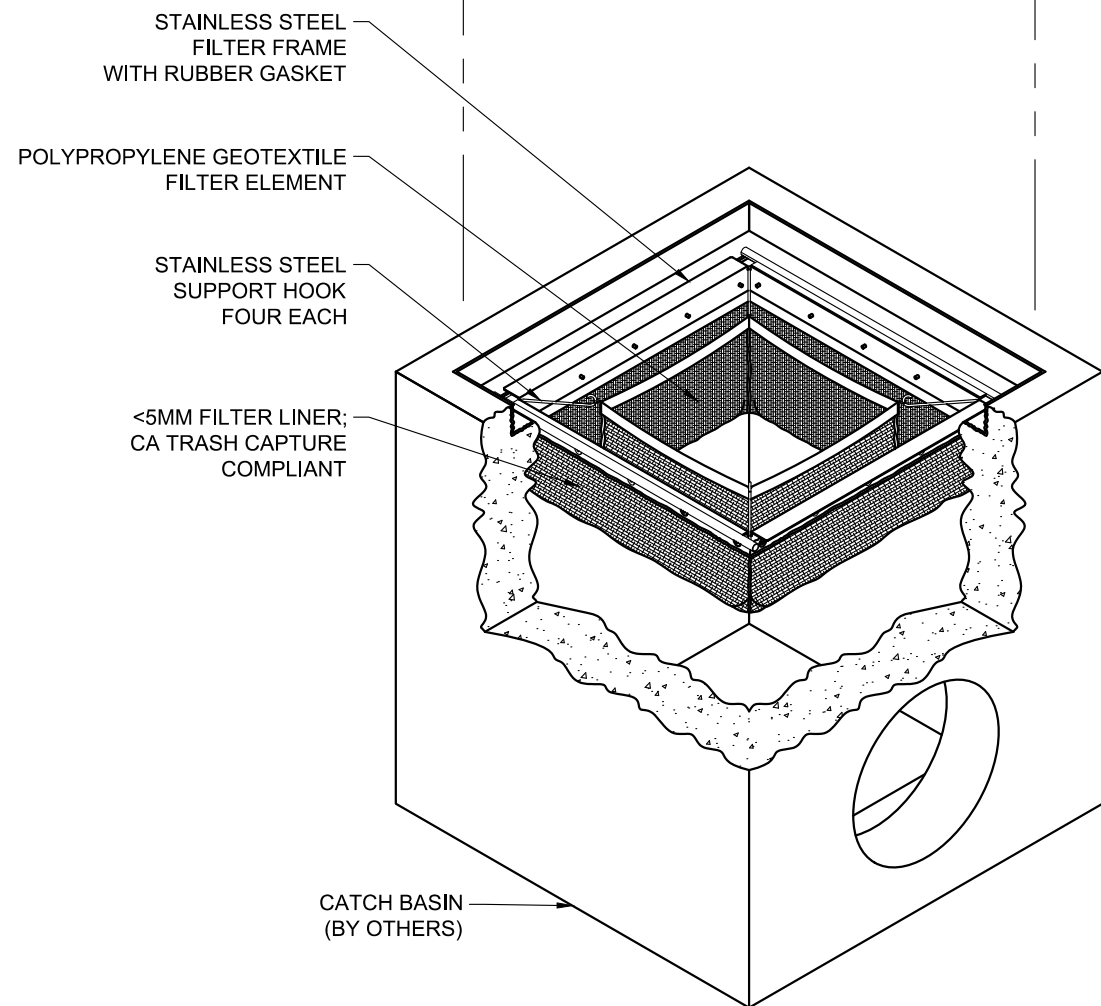

SECTION VIEW

NOTES:

1. FILTER INSERT SHALL HAVE A HIGH FLOW BYPASS FEATURE.
2. FILTER SUPPORT FRAME SHALL BE CONSTRUCTED FROM STAINLESS STEEL TYPE 304.
3. FLOGARD CURB INLET BASKET IS AVAILABLE IN SIZES TO ACCOMMODATE STANDARD INDUSTRY CATCH BASIN INLETS. NON-STANDARD/CUSTOM SIZES CAN BE ACCOMMODATED WITH MINIMAL MODIFICATION BY CONTACTING YOUR LOCAL OLDCASTLE INFRASTRUCTURE REPRESENTATIVE.
4. STORAGE CAPACITY REFLECTS 100% OF MAXIMUM SOLIDS COLLECTION PRIOR TO IMPENDING FILTERING BYPASS.
5. 36"X 36" AND LARGER GRATES WILL UTILIZE A DUAL BASKET CONFIGURATION.



Ph: 800.579.8819 | www.oldcastleinfrastructure.com/stormwater
 THIS DOCUMENT IS THE PROPERTY OF OLDCASTLE INFRASTRUCTURE, INC. IT IS CONFIDENTIAL, SUBMITTED FOR REFERENCE PURPOSES ONLY AND SHALL NOT BE USED IN ANY WAY INJURIOUS TO THE INTERESTS OF, OR WITHOUT THE WRITTEN PERMISSION OF OLDCASTLE INFRASTRUCTURE, INC. COPYRIGHT © 2021 OLDCASTLE INFRASTRUCTURE, INC. ALL RIGHTS RESERVED.

FloGard® Grate Inlet Basket

CUSTOMER		
-		
JOB NAME		
-		
DRAWING NUMBER	REVISION	SHEET
Flow Gard Grate Inlet	REV DATE	1 OF 1



APPENDIX C



MVCAC
Mosquito and Vector Control Association of California

One Capitol Mall, Suite 800 • Sacramento, CA 95814 • p: (916) 440-0826 • f: (916) 444-7462 • e: mvcac@mvcac.org

Oldcastle Infrastructure
10441 Vine Street
Lakeside, CA 92040

June 9, 2021

Dear Ms. Sanfilippo,

Thank you for the submission of the Oldcastle FloGard Grate Inlet Basket full trash capture device for review by the Mosquito and Vector Control Association of California pursuant to the SWRCB Trash Treatment Control Device Application Requirements. The Association has reviewed the conceptual drawings for the FloGard grate Inlet Basket and verifies that provisions have been included in the designs that allow for full visual access to all areas for presence of standing water, and when necessary, allows for treatments of mosquitoes.

While this verification letter confirms that inspection and treatment for the purpose of minimizing mosquito production should be possible with the FloGard Grate Inlet Basket as presented, it does not affect the local mosquito control agency's rights and remedies under the State Mosquito Abatement and Vector Control District Law. For example, if the installed device or the associated stormwater system infrastructure becomes a mosquito breeding source, it may be determined by a local mosquito control agency to be a public nuisance in accordance with California Health and Safety Code sections 2060-2067.

"Public nuisance" means any of the following:

1. Any property, excluding water that has been artificially altered from its natural condition so that it now supports the development, attraction, or harborage of vectors. The presence of vectors in their developmental stages on a property is prima facie evidence that the property is a public nuisance.
2. Any water that is a breeding place for vectors. The presence of vectors in their developmental stages in the water is prima facie evidence that the water is a public nuisance.
3. Any activity that supports the development, attraction, or harborage of vectors, or that facilitates the introduction or spread of vectors. (Heal. & Saf. Code § 2002 (j).)

Declaration of a facility or property as a public nuisance may result in penalties as provided under the Health and Safety Code. Municipalities and the vendors they work with are encouraged to discuss the design, installation, and maintenance of stormwater trash capture devices with their local mosquito control agency to reduce the potential for disease transmission and public nuisance associated with mosquito production.

Sincerely,

Bob Achermann,
MVCAC Executive Director