



**Revel Environmental Manufacturing Inc.**

sales@remfilters.com (888) 526-4736 Lic. No. 857410

Northern California  
960-B Detroit Avenue  
Concord, California 94518  
P: (925) 676-4736  
F: (925) 676-8676

Southern California  
2110 South Grand Avenue  
Santa Ana, California 92705  
P: (714) 557-2676  
F: (714) 557-2679

**RE: Trash Treatment Control Device Fact Sheet  
For  
REM Inc. Full Trash Capture TRITON PERF-FTC Device  
(Perforated Stainless Steel Trash Guard)**

December 21, 2021

Mr. Leo Cosentini  
California State Water Resources Control Board  
Division of Water Quality  
P.O. Box 100  
Sacramento, CA. 95812

Dear Mr. Cosentini,

REM Inc. would like to thank you for taking this opportunity to review our Updated Fact Sheet for the currently approved Full Trash Capture Device, our **TRITON PERF-FTC**. Throughout this application you will find the pertinent information requested from the Fact Sheet Update Requirements, presented in the requested layout.

Currently, REM Inc. has the TRITON PERF-FTC Device as an approved FTC Device as well as the Triton BFTG-FTC Insert and the Triton CPS-FTC on the approved list of devices.

Again, we thank you for taking this time to review our application, and if any additional information is required or needed, please feel free to contact us when needed.

*Charles Fleischmann*

Charles Fleischmann  
Vice President  
Revel Environmental Manufacturing, Inc.  
REM Inc.



## **Revel Environmental Manufacturing Inc.**

sales@remfilters.com (888) 526-4736 Lic. No. 857410

Northern California  
960-B Detroit Avenue  
Concord, California 94518  
P: (925) 676-4736  
F: (925) 676-8676

Southern California  
2110 South Grand Avenue  
Santa Ana, California 92705  
P: (714) 557-2676  
F: (714) 557-2679

### **Section: 1**

## **Cover Letter**

### **1A: General Description**

The TRITON PERF-FTC can be used as a stand-alone filtration device for capturing trash and debris inside of storm drain catch basins. With its intended design, it can capture pollutants and debris as small as 5mm, meeting the requirement for Full Trash Capture Devices. It does this, while still maintaining excellent flow rates due to its 51% open area. The PERF-FTC device is intended to be installed in storm drain catch basins and is designed for lateral and surface flow capturing applications depending upon configuration.

### **1B: Device Owner Contact and location information**

Charles Fleischmann  
Vice President  
960 Detroit Ave. Suite B  
Concord, CA. 94518  
(925) 676-4736  
[Charlie@remfilters.com](mailto:Charlie@remfilters.com)

### **1C: Website Information**

<https://remfilters.com>

### **1D: Manufacturing Location**

All REM TRITON products are manufactured and designed in the state of California. REM Inc. has specialized in providing storm drain filters/trash capture devices all over the country for 24+ years. \*Address location listed above.

### **1E: Brief summary of field/testing results to demonstrate device functions**

The TRITON PERF-FTC was successfully tested in capturing debris that is 5mm or greater in size, in a number of test basins located in the greater San Francisco Bay Area and Southern California. Results and pictures from these tests can be found in Section 8.

### **1F: Brief summary of limitations, and operational, sizing, and maintenance considerations**

The TRITON PERF-FTC units are extremely adaptable and customizable in terms of mounting and attaching to the many different types of catch basin configurations in the field today. Due to the many different product applications REM has been able to offer, we have been very successful in filtering many catch basins that might otherwise be “passed up” on. Each of these devices can be adjusted to fit custom layouts/structures. The proper unit is determined in part by the outgoing pipe size, and then the structure size is taken into account. The approximate installation time takes between 10-25 minutes, depending on the infrastructure layout. Maintenance on PERF-FTC devices typically involves an industrial vacuum truck when the units are about 50% loaded or as required. Maintenance should be performed at least 3 times per year or as needed.

This device is also able to house an absorbent media as well if ever required. No design modifications are needed, the media element is simply placed between the inner and outer layers of the stainless-steel support housings while maintaining its FTC requirement.

**1G: Device installation locations**

REM Inc. has been installing PERF-FTC devices in multiple California locations as well as national sales across the U.S. as this has been an approved FTC device since 2018. Some installation areas of acknowledgement would be:

City of Antioch: Dept. of Public Works

City of Concord: Dept. of Public Works

City of Hayward: Dept. of Public Works

Please feel free to ask for a more detailed reference list.

**1H: Certification Clause**

I certify under penalty of law that this document and all attachments were prepared under my direction or supervision in accordance with a system designed to assure that qualified personnel properly gather and evaluate the information submitted. Based on my inquiry of the person or persons that manage the system or those persons directly responsible for gathering the information, to the best of my knowledge and belief, the information submitted is true, accurate, and complete. I am aware that there are significant penalties for submitting false information, including the possibility of fine and imprisonment for knowing violations.

*Charles Fleischmann*

Charles Fleischmann  
Vice President  
REM Inc.

**Section: 3      Physical Description**

<b>3A:</b>	<u>Trash Capture</u>	<b>5</b>
<b>3B:</b>	<u>Peak Flows/Trash Volumes</u>	<b>5</b>
<b>3C:</b>	<u>Hydraulic Capacity</u>	<b>5</b>
<b>3D:</b>	<u>Comparison Table</u>	<b>8</b>
<b>3E:</b>	<u>Design Drawings</u>	<b>11</b>
<b>3F:</b>	<u>Alternative Configurations</u>	<b>17</b>
<b>3G:</b>	<u>Internal Bypass</u>	<b>17</b>
<b>3H:</b>	<u>Previously Trapped Trash</u>	<b>17</b>
<b>3I:</b>	<u>Calibration Feature</u>	<b>17</b>
<b>3J:</b>	<u>Photos</u>	<b>27</b>
<b>3K:</b>	<u>Material Type</u>	<b>18</b>
<b>3L:</b>	<u>Design Life</u>	<b>18</b>

**Section: 4      Installation Guidance**

<b>4A:</b>	<u>Device installation procedures and considerations</u>	<b>19</b>
<b>4B:</b>	<u>Description of installation limitations and non-standard installation procedures</u>	<b>25</b>
<b>4C:</b>	<u>Methods for diagnosing and correcting installation errors</u>	<b>25</b>

**Section: 5      Operation and Maintenance Information**

<b>5A:</b>	<u>Device inspection procedures and frequency considerations</u>	<b>25</b>
<b>5B:</b>	<u>Maintenance frequency considerations due to capacity at various volumes</u>	<b>25</b>
<b>5C:</b>	<u>Maintenance procedures</u>	<b>25</b>
<b>5D:</b>	<u>Essential equipment and materials for proper maintenance</u>	<b>25</b>
<b>5E:</b>	<u>Description of effects of deferred maintenance</u>	<b>26</b>
<b>5F:</b>	<u>Repair procedures for device components</u>	<b>26</b>

**Section: 6      Vector Control Accessibility**

<b>6A:</b>	<u>Date of device submittal to MVCAC</u>	<b>26</b>
<b>6B:</b>	<u>Description that demonstrates vector control personnel accessibility</u>	<b>27</b>
<b>6C:</b>	<u>Letter of Certification from MVCAC</u>	<b>33</b>

**Section: 7      Reliability Information**

<b>7A:</b>	<u>Estimated design life of device</u>	<b>34</b>
<b>7B:</b>	<u>Warranty information</u>	<b>34</b>
<b>7C:</b>	<u>Customer support information</u>	<b>34</b>

**Section: 8      Field/Lab Testing Information and Analysis**

<b>8A:</b>	<u>Device field testing and results</u>	<b>34</b>
------------	---	-----------

## Section 3: Physical Description

### 3A: Trash Capture

The TRITON-PERF-FTC device utilizes a Perforated Stainless Steel filter element, which has a 51% open area. This open area helps minimize occlusion and blinding while filtering at high volumes. The PERF is housed on the exterior of a stainless steel cartridge or as a stand alone filter element in a wide range of configurations depending upon the many different types and sizes of catch basin available today.

### 3B: Peak Flows/Trash Volumes

PERF-FTC devices are primarily sized in accordance with the catch basins outgoing pipe diameter, inside wall dimensions or throat, below the grate. Selecting the correct size unit not only helps to ensure max flow/bypass rates are met, but also maximum trash capturing volume. The catch basin structure size is next used as a determining factor for identifying the proper size unit. For example: a 2' X 3' catch basin could utilize a model TR2436-PERF-FTC which allows enough spacing from the walls for incoming water flows to be fully captured.

### 3C: Hydraulic Capacity

Section 1)

Standard size models shown:

#### Inserts:

<i>Model:</i>	TR1818	TR2436	TR24RD	TR24SR	TR36RD
<i>Housing Body Width:</i>	17.5" X 17.5"	34.5" X 23.5"	23.5" Dia.	23.5" X 23.5"	35" Dia.
<i>Cartridge Height:</i>	8"	8"	12"	12"	16"
<i>Cartridge</i>	TR10-CART(8)	TR14-CART(8)	TR14-CART(12)	TR14-CART(12)	TR14-CART(16)
<i>Cartridge Diameter:</i>	10" Dia.	14" Dia.	14" Dia.	14" Dia.	14" Dia.
<i>Max Treatment Rate: (Empty)</i>	3.18 (CFS)	4.42 (CFS)	6.64 (CFS)	6.64 (CFS)	8.85 (CFS)
<i>Treatment Rate at 50% capacity:</i>	1.59 (CFS)	2.21 (CFS)	3.32 (CFS)	3.32 (CFS)	4.42 (CFS)
<i>Treatment Rate at 75% capacity:</i>	.79 (CFS)	1.11 (CFS)	1.66 (CFS)	1.66 (CFS)	2.21 (CFS)
<i>Bypass Flow:</i>	5.14 (CFS)	13.15 (CFS)	13.15 (CFS)	13.15 (CFS)	13.15 (CFS)

**Top Hat:**

<b>Model:</b>	TR1818-TH	TR2436-TH	TR24RD-TH	TR36RD-TH
<b>Width:</b>	17.5" X 17.5"	23.5" X 34.5"	23.5" Dia.	35" Dia.
<b>Cartridge Height:</b>	8"	8"	12"	16"
<b>Cartridge:</b>	TR10CART(8)	TR14CART(8)	TR14CART(12)	TR14CART(16)
<b>Cartridge Diameter:</b>	10"	14"	14"	14"
<b>Max Treatment Rate: (Empty)</b>	3.18 (CFS)	4.42 (CFS)	6.64 (CFS)	8.85 (CFS)
<b>Treatment Rate at 50% capacity:</b>	1.59 (CFS)	2.21 (CFS)	3.32 (CFS)	4.42 (CFS)
<b>Treatment Rate at 75% capacity:</b>	.79 (CFS)	1.11 (CFS)	1.66 (CFS)	2.21 (CFS)
<b>Bypass Flow:</b>	5.14 (CFS)	13.15 (CFS)	13.15 (CFS)	13.15 (CFS)

**Curb Inlet:**

<b>Model:</b>	TRC2.0	TRC3.5	TRC7.0	TRC14.0
<b>Width:</b>	9"	9"	9"	9"
<b>Height:</b>	12.5"	12.5"	12.5"	12.5"
<b>Length:</b>	2'	3.5'	7'	14'
<b>Max Treatment Rate: (Empty)</b>	3.62 (CFS)	6.33 (CFS)	12.67 (CFS)	25.31 (CFS)
<b>Treatment Rate at 50% capacity:</b>	1.81 (CFS)	3.16 (CFS)	6.33 (CFS)	12.65 (CFS)
<b>Treatment Rate at 75% capacity:</b>	.91 (CFS)	1.58 (CFS)	3.16 (CFS)	6.32 (CFS)
<b>Bypass Flow:</b>	8.35 (CFS)	14.24 (CFS)	28.42 (CFS)	56.35 (CFS)

**Area Drain:**

<b>Model:</b>	ADF-7	ADF-10	ADF-14	ADF-24
<b>Diameter:</b>	7" Dia.	10" Dia.	14" Dia.	24" Dia.
<b>Height:</b>	8"	8"	16"	16"
<b>Cartridge:</b>	TR7CART(8)	TR10CART(8)	TR14CART(16)	TR24CART(16)
<b>Bypass:</b>	3" Dia.	6" Dia.	10" Dia.	20" Dia.
<b>Max Treatment Rate: (Empty)</b>	2.22 (CFS)	3.18 (CFS)	8.85 (CFS)	15.26 (CFS)
<b>Treatment Rate at 50% capacity:</b>	1.1 (CFS)	1.59 (CFS)	4.42 (CFS)	7.63 (CFS)
<b>Treatment Rate at 75% capacity:</b>	.55 (CFS)	.79 (CFS)	2.21 (CFS)	3.81 (CFS)
<b>Bypass Flow:</b>	1.61 (CFS)	5.14 (CFS)	13.15 (CFS)	51.29 (CFS)

**TDAM:**

<b>Model:</b>	TT2	TDAM5(5)	TDAM8(10)	TDAM12(5)
<b>Width:</b>	4"	5"	8"	12"
<b>Height:</b>	4"	5"	10"	5"
<b>Trench Width:</b>	4"	5"	8"	12"
<b>Bypass:</b>	3" X 4"	3" X 5"	3" X 8"	3" X 12"
<b>Max Treatment Rate: (Empty)</b>	.025 (CFS)	.17 (CFS)	.52 (CFS)	.40 (CFS)
<b>Treatment Rate at 50% capacity:</b>	.013 (CFS)	.08 (CFS)	.26 (CFS)	.20 (CFS)
<b>Treatment Rate at 75% capacity:</b>	.006 (CFS)	.04 (CFS)	.13 (CFS)	.11 (CFS)
<b>Bypass Flow:</b>	.44 (CFS)	.55 (CFS)	.88 (CFS)	1.33 (CFS)

Section 2)

To determine the treatment rates, a commonly used equation was calculated. This is similar to the method used by the County of Los Angeles Dept. of Public Works in a 2006 report on Full Capture Screen and Bypass Requirements. An example of the equation is below:

$$Q_{MTR} = \frac{C_d A \sqrt{2gh}}{SF}$$

Calculation for the model TR24SR-PERF-FTC Device:

$$Q_{MTR} = \frac{0.60 * 2.08sf \sqrt{2 * \frac{32.2ft}{s^2} * .66ft}}{2}$$

This equals: **3.32 CFS** for the maximum treatment flow rate, while utilizing a safety factor of 2.

Section 3)

N/A – No alternative configurations effect the hydraulic capacities of the devices.

**3D: Comparison Table**

\*For standard sized models. More sizes and custom configurations are available.

Inserts:

<b>Model:</b>	<b>TR1818</b>	<b>TR2436</b>	<b>TR24RD</b>	<b>TR24SR</b>	<b>TR36RD</b>
<b>Housing Body Width:</b>	17.5" X 17.5"	34.5" X 23.5"	23.5" Dia.	23.5" X 23.5"	35" Dia.
<b>Cartridge Height:</b>	8"	8"	12"	12"	16"
<b>Cartridge</b>	TR10-CART(8)	TR14-CART(8)	TR14-CART(12)	TR14-CART(12)	TR14-CART(16)
<b>Cartridge Diameter:</b>	10"	14" Dia.	14" Dia.	14" Dia.	14" Dia.
<b>Max Treatment Rate: (Empty)</b>	3.18 (CFS)	4.42 (CFS)	6.64 (CFS)	6.64 (CFS)	8.85 (CFS)
<b>Maximum Trash Capture Volume: (gallons)</b>	7.8 (Gallons)	22.7 (Gallons)	14.5 (Gallons)	14.5 (Gallons)	59.8 (Gallons)



**Top Hat:**

<b>Model:</b>	TR1818-TH	TR2436-TH	TR24RD-TH	TR36RD-TH
<b>Width:</b>	17.5" X 17.5"	23.5" X 34.5"	23.5" Dia.	35" Dia.
<b>Cartridge Height:</b>	8"	8"	12"	16"
<b>Cartridge:</b>	TR10CART(8)	TR14CART(8)	TR14CART(12)	TR14CART(16)
<b>Cartridge Diameter:</b>	10"	14"	14"	14"
<b>Max Treatment Rate: (Empty)</b>	3.18 (CFS)	4.42 (CFS)	6.64 (CFS)	8.85 (CFS)
<b>Maximum Trash Capture Volume: (gallons)</b>	8.51 Gallons	24.5 Gallons	15.51 Gallons	59.84 Gallons

**Curb Inlet:**

<b>Model:</b>	TRC2.0	TRC3.5	TRC7.0	TRC14.0
<b>Width:</b>	9"	9"	9"	9"
<b>Height:</b>	12.5"	12.5"	12.5"	12.5"
<b>Length:</b>	2'	3.5'	7'	14'
<b>Max Treatment Rate: (Empty)</b>	.82 (CFS)	1.93 (CFS)	3.88 (CFS)	7.74 (CFS)
<b>Maximum Trash Capture Capacity: (Gallons)</b>	11.69 Gallons	20.45 Gallons	40.9 Gallons	81.8 Gallons

**Area Drain:**

<b>Model:</b>	ADF-7	ADF-10	ADF-14	ADF-24
<b>Diameter:</b>	7" Dia.	10" Dia.	14" Dia.	24" Dia.
<b>Height:</b>	8"	8"	16"	16"
<b>Cartridge:</b>	TR7CART(8)	TR10CART(8)	TR14CART(16)	TR24CART(16)
<b>Bypass:</b>	3" Dia.	6" Dia.	10" Dia.	20" Dia.
<b>Max Treatment Rate: (Empty)</b>	2.22 (CFS)	3.18 (CFS)	8.85 (CFS)	15.26 (CFS)
<b>Maximum Trash Capture Capacity: (Gallons)</b>	1.67 Gallons	3.41 Gallons	13.33 Gallons	39.17 Gallons

**TDAM:**

<b>Model:</b>	TT2	TDAM5(5)	TDAM8(10)	TDAM12(5)
<b>Width:</b>	4"	5"	8"	12"
<b>Height:</b>	4"	5"	10"	5"
<b>Trench Width:</b>	4"	5"	8"	12"
<b>Bypass:</b>	3" X 4"	3" X 5"	3" X 8"	3" X 12"
<b>Max Treatment Rate: (Empty)</b>	.025 (CFS)	.17 (CFS)	.52 (CFS)	.40 (CFS)
<b>Maximum Trash Capture Capacity: (Gallons)</b>	3.32 Gallons	5.19 Gallons	16.62 Gallons	12.47 Gallons

### 3E: Design Drawings



#### Revel Environmental Manufacturing Inc.

sales@remfilters.com (888) 526-4736 Lic. No. 857410

Northern California  
960-B Detroit Avenue  
Concord, California 94518  
P: (925) 676-4736  
F: (925) 676-8676

Southern California  
2110 South Grand Avenue  
Santa Ana, California 92705  
P: (714) 557-2676  
F: (714) 557-2679

# REM TRITON PERF - FTC

#### Product Overview:

REM's PERF-FTC Filter Screen utilizes 22ga., Type 304 Stainless Steel Perforation. Perforated stainless steel is configured with a 4.8mm openings, having 51% Open Area for excellent flow rates comparative to size. The Stainless Steel Perforation is designed to capture 100% of trash and debris at 5 mm or greater in size. PERF-FTC is housed in stainless steel cartridges in a wide range of configurations, depending upon the many different types and sizes of catch basin available today. PERF-FTC may be utilized in both new construction or retrofitted in existing catch basin filters. They are sized to spec or modified in the field for drains with unusual dimensions and unique frame and grates. Filter Cartridges may be easily removed when servicing. Different media strategies can be combined with PERF Screen Design to optimized capturing for specific pollutant of concerns.

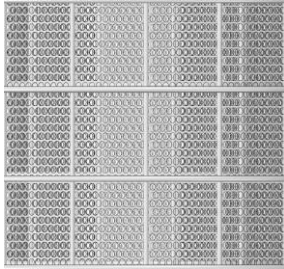

A side view of the Type 304 13ga. Stainless Steel welded 2" square housing with 22ga Type 304 Stainless Steel Perforation.

#### Notes:

- Cartridge support housing uses Type 304 13ga., stainless steel, with 2" welded square opening.
- Perforated stainless steel is configured with a 4.8mm openings, having 51% Open Area for excellent flow rates comparative to size.
- The Stainless Steel Perforation is designed to capture 100% of trash and debris at 5 mm or greater in size.
- Flow rate based on .10 cfs, per square foot.
- **Made in the USA.**
- Maintenance information and replacement REM Media Packs (If used) are available upon request by contacting REM at sales@remfilters.com or (888) 526-4736.



#### General Flow Rates Per Square Foot

1' X 1' Square Foot = .11 Cfs.  
2' X 2' Square Foot = .42 Cfs.  
3' X 3' Square Foot = .95 Cfs.



Booted Stainless Area Drain Filter.



TR2436-PERF Inlet Filter.



ADF-14-PERF



TDAM12-PERF



TR2436-TH-PERF Top Hat Filter.



MiniGT6-PERF

# REM TRITON PERF-FTC INSERT Cartridge

## Standard size dimensions

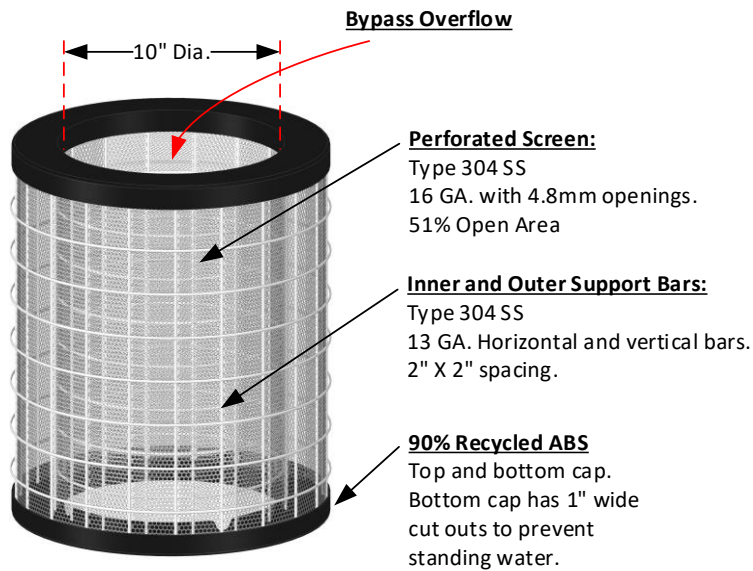

**Cartridge Height**  
Unit can be sized to any 2" increment in height. (2"-32")

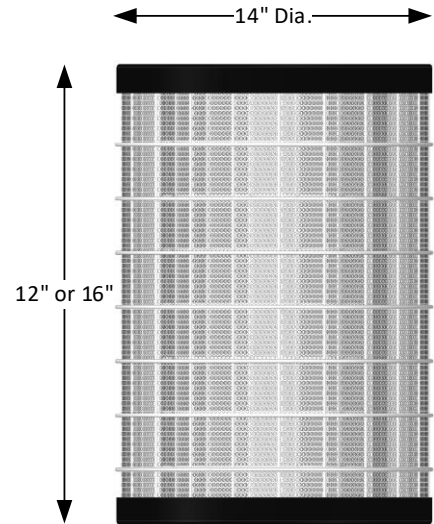

**Locking Ring**

Cartridge locks into place with a simple ¼ turn to the right. To remove, turn to the left.

**Notes:**

- Units are constructed using a 13 GA. Stainless Steel inner and outer housing support for added structural integrity.
- Perforated Stainless Steel is configured with a 51% Open Area for excellent flow rates.
- Custom sizes and configurations are available.
- Multiple units can be mounted vertically to increase capture capacity.
- PERF Cartridge unit is capable of housing an absorbent media if ever required, with no retrofitting or modifications needed.

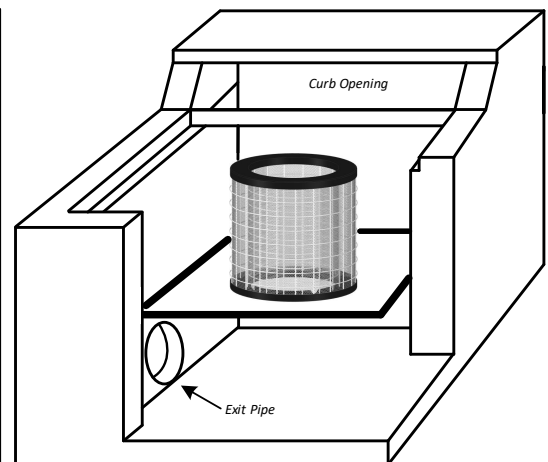
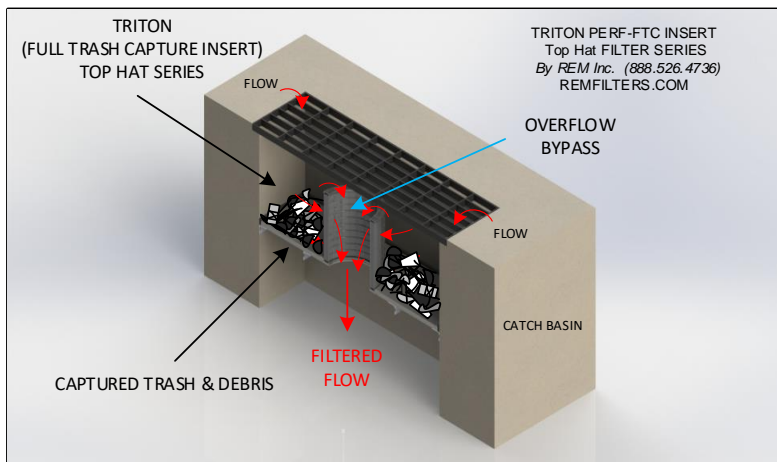

Model: Insert (Cartridge Size)	Diameter:	Height:	Filtered Flow Rate:	Bypass Diameter:	Bypass Flow Rate:
TR14(12) Cartridge	14"	12"	6.64 (CFS)	10"	13.15 (CFS)
TR14(16) Cartridge	14"	16"	8.85 (CFS)	10"	13.15 (CFS)



**Revel Environmental Manufacturing Inc.**

sales@remfilters.com (888) 526-4736 Lic. No. 857410

Northern California  
960-B Detroit Avenue  
Concord, California 94518  
P: (925) 676-4736  
F: (925) 676-8676

Southern California  
2110 South Grand Avenue  
Santa Ana, California 92705  
P: (714) 557-2676  
F: (714) 557-2679

# REM TRITON INSERT – PERF - FTC

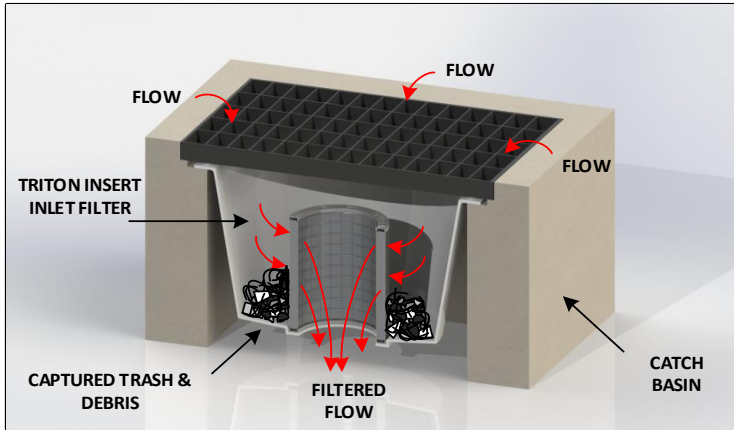

**Product Overview:**

REM's TRITON – INSERT-PERF Filters are multipurpose catch basin filters designed to capture sediment, trash, debris, suspended solids, and other storm water pollutants. They may be utilized in new construction or retrofitted in existing catch basin structures. They are sized to spec or modified in the field for drains with unusual dimensions and unique frame and grates. The TRITON Perforated Stainless (PERF) Screen that is designed to capture debris, trash and sediment while sustaining very high treatment rates as a Full Trash Capture System. Capturing 100% of particles at 5mm or greater in size. Filter Cartridges may be easily removed when servicing. Media strategy may be optimized for specific pollutant concerns.

**Standard Size Dimensions** (Not all model and sizes are listed here)

Model:	TR1818-PERF	TR2436-PERF	TR24RD-PERF	TR36RD-PERF
Width:	17.5" X 17.5"	34.5" X 23.5"	23.5" Dia.	35"
Cartridge Height:	8"	8"	12"	16"
Cartridge	TR10-CART(8)	TR14-CART(8)	TR14-CART(12)	TR14-CART(16)
Cartridge Diameter:	10" Dia.	14" Dia.	14" Dia.	14" Dia.
Max Treatment Rate:	3.18 (CFS)	4.42 (CFS)	6.64 (CFS)	8.85 (CFS)
Bypass Flow:	5.14 (CFS)	13.15 (CFS)	13.15 (CFS)	13.15 (CFS)

**Notes:**

- Filter bodies are constructed using **100% recycled** High Molecular Weight Polyethylene Plastic (HMWPE) with U.V. inhibitors.
- Filter cartridge housings are constructed utilizing Type 304 13ga. Stainless Steel, with 2" welded square openings.
- Removable cartridge tops and bottoms are constructed utilizing over 90% recycled ABS Plastic.
- Filter Screen utilizes 22ga., Type 304 Stainless Steel Perforation.
- Perforated Stainless Steel is configured with a 4.8mm openings, having 51% Open Area for excellent flow rates comparative to its size.
- REM TRITON filter cartridges can be removed for ease of cleaning and maintenance.
- Filter designs include a high flow overflow bypass to eliminate pooling or flooding during heavy rain events.
- Maintenance information and replacement REM Media Packs are available upon request by contacting REM at sales@remfilters.com or (888) 526-4736.
- **Made in the USA.**

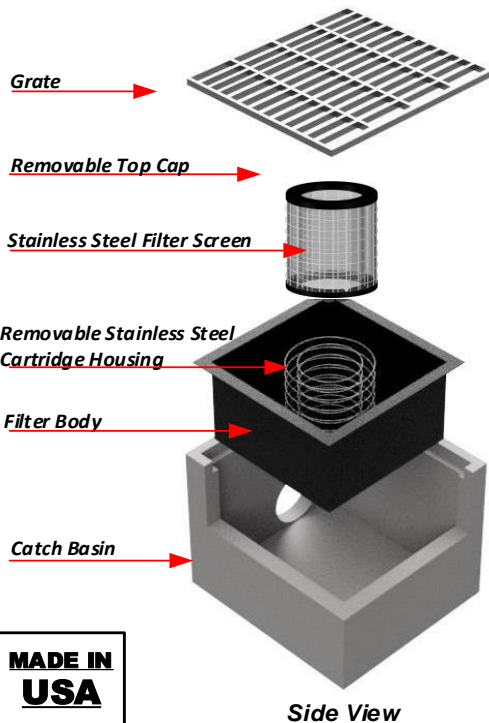

TR2424 Removing Cartridge



TR2424-PERF Installed

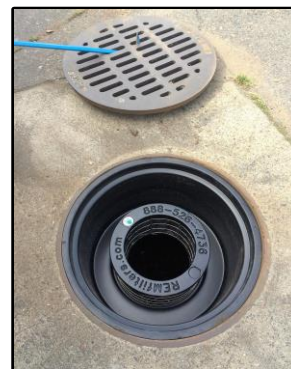

TR24RD-PERF Installed



Round Catch Basin



**Revel Environmental Manufacturing Inc.**

sales@remfilters.com (888) 526-4736 Lic. No. 857410

Northern California  
960-B Detroit Avenue  
Concord, California 94518  
P: (925) 676-4736  
F: (925) 676-8676

Southern California  
2110 South Grand Avenue  
Santa Ana, California 92705  
P: (714) 557-2676  
F: (714) 557-2679

# REM TRITON TOP HAT – PERF - FTC

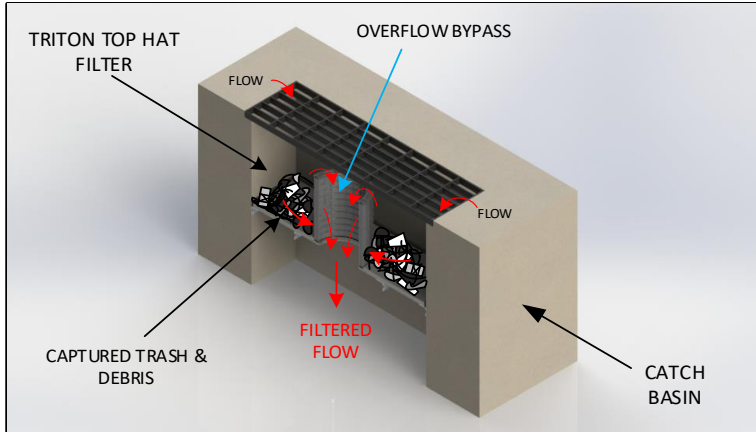

**Product Overview:**

REM's TRITON – Top Hat Filters were designed to provide a highly adaptable solution that allows the flexibility to maximize the filter treatment flow rate and pollutant debris capturing capacity. This multipurpose design allows the system to be installed in many different catch basin configurations. Top Hat Filters are designed to capture sediment, trash, debris, suspended solids, and other storm water pollutants. They may be utilized in new construction or retrofitted in existing catch basin structures. They are sized to spec or modified in the field for drains with unusual dimensions and unique frame and grates. The TRITON Perforated Stainless (PERF) Screen that is designed to capture debris, trash and sediment while sustaining very high treatment rates as a Full Trash Capture System. Capturing 100% of particles at 5mm or greater in size. Filter Cartridges may be easily removed when servicing. Media strategy may be optimized for specific pollutant concerns.

**Standard Size Dimensions** (Not all model and sizes are listed here)

Model:	TR1818-TH-PERF	TR2436-TH-PERF	TR24RD-TH-PERF	TR36RD-TH-PERF
Width:	17.5" X 17.5"	34.5" X 23.5"	23.5" Dia.	35"
Cartridge Height:	8"	8"	12"	16"
Cartridge:	TR10-CART(8)	TR14-CART(8)	TR14-CART(12)	TR14-CART(16)
Cartridge Diameter:	10" Dia.	14" Dia.	14" Dia.	14" Dia.
Max Treatment Rate:	3.18 (CFS)	4.42 (CFS)	6.64 (CFS)	8.85 (CFS)
Bypass Flow:	5.14 (CFS)	13.15 (CFS)	13.15 (CFS)	13.15 (CFS)

**Notes:**

- Base plates are constructed using High Density Polyethylene Plastic (HDPE).
- Filter cartridge housings are constructed utilizing Type 304 13ga. Stainless Steel, with 2" welded square openings.
- Removable cartridge tops and bottoms are constructed utilizing over 90% recycled ABS Plastic.
- Filter Screen utilizes 22ga., Type 304 Stainless Steel Perforation.
- Perforated Stainless Steel is configured with a 4.8mm openings, having 51% Open Area for excellent flow rates comparative to its size.
- REM TRITON filter cartridges can be removable for ease of cleaning and maintenance.
- Filter designs include a high flow overflow bypass to eliminate pooling or flooding during heavy rain events.
- Maintenance information and replacement REM Media Packs are available upon request by contacting REM at sales@remfilters.com or (888) 526-4736.
- **Made in the USA.**

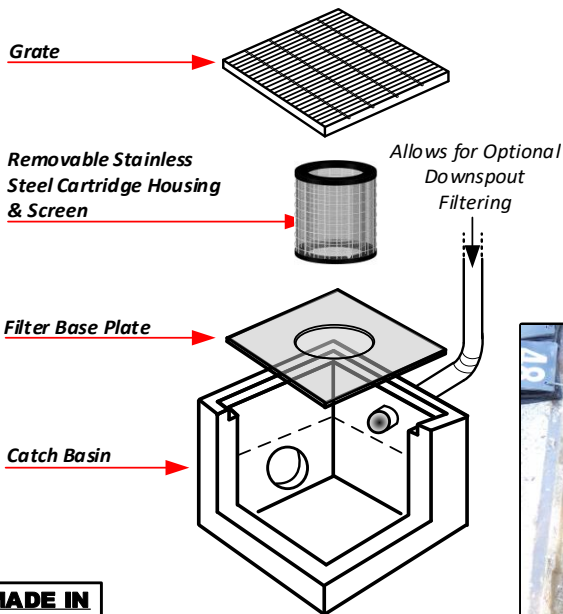

Side View



Model: TR3636-TH-PERF Installed



Round Catch Basin Top Hat



**Revell Environmental Manufacturing Inc.**

sales@remfilters.com (888) 526-4736 Lic. No. 857410

Northern California  
960-B Detroit Avenue  
Concord, California 94518  
P: (925) 676-4736  
F: (925) 676-8676

Southern California  
2110 South Grand Avenue  
Santa Ana, California 92705  
P: (714) 557-2676  
F: (714) 557-2679

# REM TRITON CURB INLET – PERF - FTC

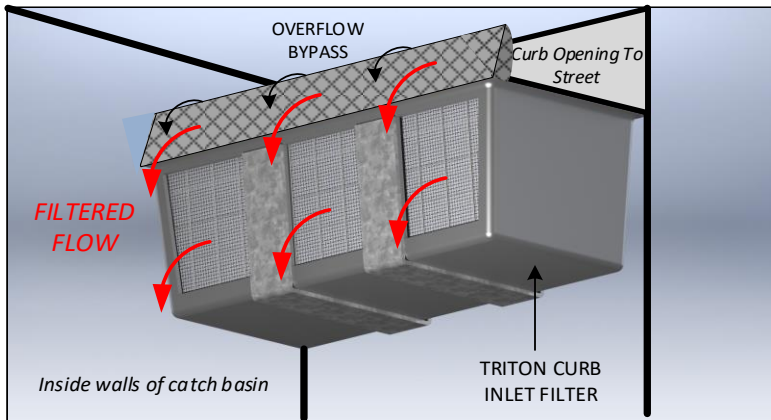

**Product Overview:**

REM designed the TRITON -TRC (Curb Inlet) Filter Series to provide a highly adaptable solution that allows the flexibility to maximize the filter treatment flow rates and pollutant capturing capacity. TRITON - TRC Filters may be utilized in new construction or retrofitted in existing catch basin structures. They are sized to spec and scalable for all different lengths of curb inlet catch basins. The TRITON TRC - PERF – FTC Series uses Perforated Stainless Steel (PERF) Screen that is designed to capture debris, trash and sediment while sustaining very high treatment rates as a Full Trash Capture System. Capturing 100% of particles at 5mm or greater in size. Media strategy may be optimized for specific pollutant concerns.

**Standard Size Dimensions** (Not all model and sizes are listed here)

Model:	TRC2.5-PERF	TRC3.5-PERF	TRC7.0-PERF	TR14.0-PERF
Width/Height:	12"/12"	12"/12"	12"/12"	12"/12"
Length:	2.5'	3.5'	7'	14'
Max Treatment Rate:	3.62 (CFS)	6.33 (CFS)	12.67 (CFS)	25.31 (CFS)
Bypass Flow:	*8.35 (CFS)	*14.24 (CFS)	*28.42 (CFS)	*56.35 (CFS)

\*Note: Potential overflow bypass will be equal to or greater than the curb opening in the street. Device has a greater area for bypass which is larger than the curb opening.

**Notes:**

- Filter bodies are constructed using **100% recycled High Impact Polystyrene plastic (HIPS)** with UV inhibitors and rubber additives.
- Filter screen utilizes 22ga, Type 304 Stainless Steel perforation.
- Perforated Stainless Steel is configured with a 4.8mm openings, having a 51% Open Area for excellent flow rates comparative to its size.
- Optional Stainless Steel Cartridge housings are capable of housing an absorbent media if ever required, with no retrofitting or modifications needed.
- REM TRITON filter cartridges are removable for ease of cleaning and maintenance.
- Filter designs include a high flow overflow bypass to eliminate pooling or flooding during heavy rain events.
- Maintenance information and replacement REM Media Packs are available upon request by contacting REM at sales@remfilters.com or (888) 526-4736.
- **Made in the USA.**

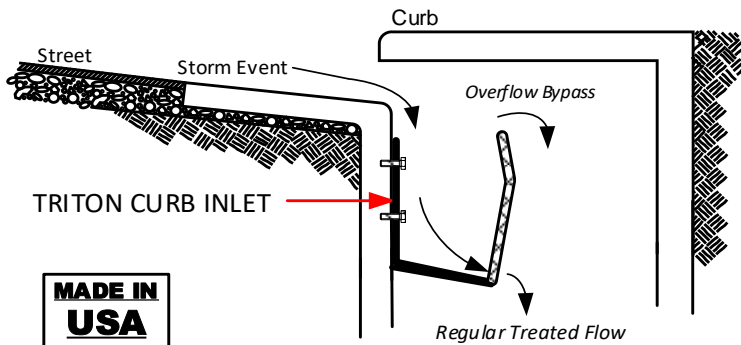
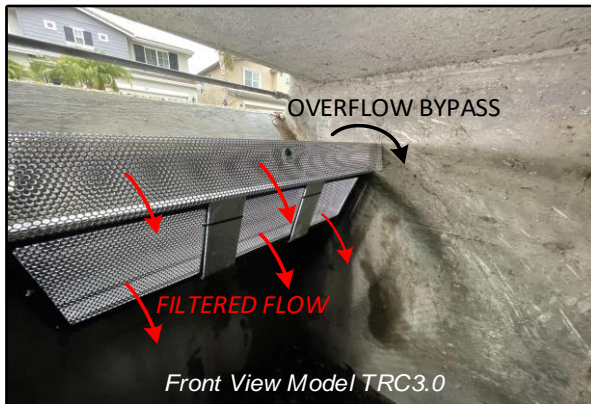



**Revel Environmental Manufacturing Inc.**

sales@remfilters.com (888) 526-4736 Lic. No. 857410  
 Northern California 960-B Detroit Avenue Concord, California 94518 P: (925) 676-4736 F: (925) 676-8676  
 Southern California 2110 South Grand Avenue Santa Ana, California 92705 P: (714) 557-2676 F: (714) 557-2679

# REM TRITON TDAM - PERF - FTC

**Product Overview:**

REM designed the TRITON -TDAM Filter Series to provide a highly adaptable solution that allows the flexibility to maximize the filter treatment flow rates and pollutant capturing capacity in trench drain and shallow type drains applications. The TRITON TDAM - PERF - FTC Series uses Perforated Stainless Steel (PERF) Screen that is designed to capture debris, trash and sediment while sustaining very high treatment rates as a Full Trash Capture System. Capturing 100% of particles at 5mm or greater in size. TRITON -TDAM Filters can be sized to fit most industry standard trench drains, parkway drains, shallow structures, catch basins, etc. They are sized to spec and scalable for all different lengths and applications. Media strategy may also be optimized for specific pollutant concerns.

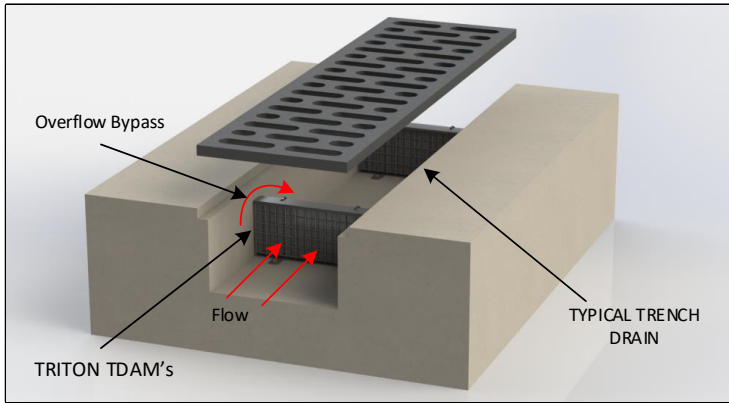

**Standard Size Dimensions** (Not all model and sizes are listed here)

Model:	TT2-PERF	TDAM5(5)-PERF	TDAM8(10)-PERF	TDAM12(5)-PERF
Width:	4"	5"	8"	12"
Height:	4"	5"	10"	5"
Trench Width	4"	5"	8"	12"
Est. Bypass	.44 (CFS)	.55 (CFS)	.88 (CFS)	1.33 (CFS)
Max Treatment Rate:	.02 (CFS)	.17 (CFS)	.52 (CFS)	.40 (CFS)

Note: Potential overflow bypass will depend upon the dept of each trench drain.

**Notes:**

- TDAM housings are constructed utilizing Type 304 16ga. Stainless Steel, with 1" and 2" welded square openings.
- Removable cartridge tops and bottoms are constructed utilizing over 90% recycled ABS Plastic or fiberglass.
- Filter screen utilizes 22ga, Type 304 Stainless Steel perforation.
- Perforated Stainless Steel is configured with a 4.8mm openings, having a 51% Open Area for excellent flow rates comparative to its size.
- REM TRITON filter cartridges can be removable for ease of cleaning and maintenance.
- Filter designs include a high flow overflow bypass to eliminate pooling or flooding during heavy rain events.
- Optional Stainless Steel Cartridge housings are capable of housing an absorbent media if ever required, with no retrofitting or modifications needed.
- Maintenance information and replacement REM Media Packs are available upon request by contacting REM at sales@remfilters.com or (888) 526-4736.
- **Made in the USA.**

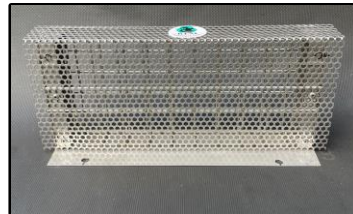
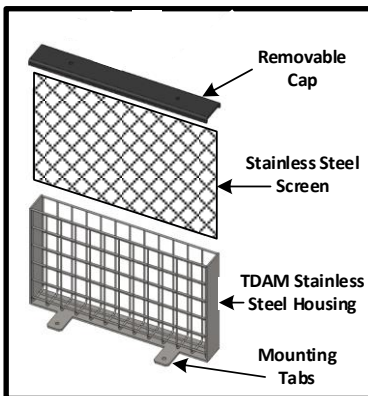

TDAM12 (5.5) - PERF

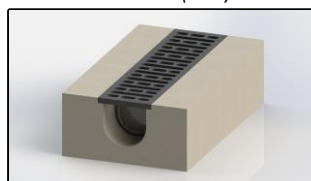

Rounded bottom trench drains.



TDAM (TT2)-PERF for rounded bottom trench drains.



TDAM15 (5.5) installed

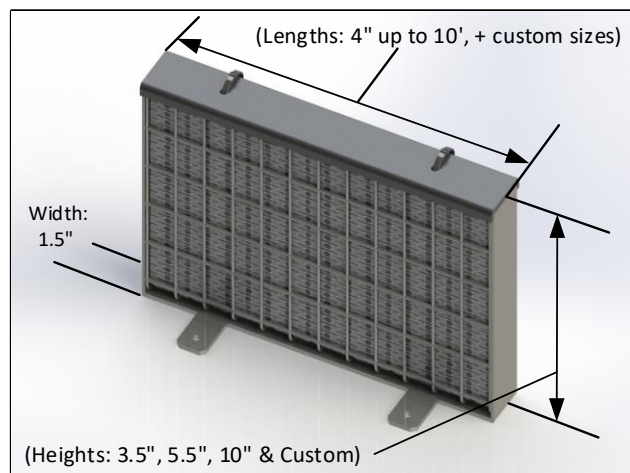



### 3F: Alternative Configurations

There are no alternative configurations.

### 3G: Internal Bypass

All of the TRITON PERF-FTC Filters have built-in overflow bypass systems, this is breached only when the device has become inundated with an excessive amount of debris and the device has reached its debris holding capacity, or during a large storm event that exceeds the hydraulic capacity of the device. Essentially the device would need to be at 100% capacity for the bypass level to be reached.

It is ultimately the responsibility of the engineer and/or deciding party to determine that the correct unit size is appropriate for the selected basin and corresponding flow capacity.

### 3H: Previously Trapped Trash

With the design of the TRITON PERF-FTC, trash should only be re-introduced in a case where the device has reached 100% capacity during normal operating conditions. REM recommends that the devices are cleaned and maintained before or at 50% capacity to ensure proper functionality.

### 3I: Calibration Feature

These devices do not contain any adjustable calibration features.

### 3J: Photos



TR2436



TR24SR



TR3636-TH

### **3K: Material Type**

The design and construction of the TRITON PERF-FTC is comprised of the following materials: Type 304 stainless steel, 90% recycled content ABS plastic cap with UV Inhibitors or a fiberglass cap. The main housing and structural support body is made up of an inner and outer wall of 13 GA. Type 304 stainless steel welded mesh with 2" X 2" square openings. The filter housings are comprised of 100% recycled HMWPE (High Molecular Weight Polyethylene) and the PERF, which is a type 304 Stainless-Steel, it is 22 GA. with 4.8mm openings which creates a total open area of 51%.

### **3L: Design Life**

Under normal operations and with the impact of large storm events, the TRITON PERF-FTC has an estimated lifespan of 20+ years. Naturally occurring elements and mineral saturation do not have a resounding effect on either the stainless steel, HMWPE, fiberglass or the ABS used in construction.

*This section intentionally left blank*

## Section 4: Installation Guidance

### 4A: Device installation procedures and considerations



**Revel Environmental Manufacturing Inc.**  
 sales@remfilters.com (888) 526-4736 Lic. No. 857410

Northern California Southern California  
 960-B Detroit Avenue 2110 South Grand Avenue  
 Concord, California 94518 Santa Ana, California 92705  
 P: (925) 676-4736 P: (714) 557-2676  
 F: (925) 676-8676 F: (714) 557-2679

## INSTALLATION INSTRUCTIONS FOR THE TRITON MODEL: INSERT – PERF - FTC (Designed for Square and Round catch basins and other applications)

#### Step 1)

If your TRITON Insert Filter has been pre-cut for you, simply remove the grate, clean any debris that is found on the ledge that the grate rests on.

#### Step 2)

Place Filter Cartridge inside of unit, and line up with stainless steel screws on the bottom of the cartridge. Press down and twist 1/6<sup>th</sup> of a turn to lock cartridge in place, making sure filter is snug enough to prevent water from bypassing. Insert filter housing into catch basin as to where the flanges are resting on the grate & frame ledges. Place grate back on catch basin.

#### Step 3)

If you received your unit un-cut, trim the flanges of the filter to be 1/2" smaller than the frame that surrounds the grate on the two support sides. Trim the other two sides that will not be supported to be 1/2" smaller than the clear frame opening, attach the supplied bulb gasket to the non-supported sides and set the Insert Filter into place. Place grate back on catch basin.

**Note:** Round units will be trimmed to 1/4" smaller diameter than the size of the grate and will not use an attachable bulb gasket.

#### TOOLS REQUIRED:

- 1) Skil saw.
- 2) Snips.
- 3) Hammer Drill, with 1/4" masonry drill bit.
- 4) Hammer.
- 5) 1/4" X 2" or 3" Concrete Anchors. i.e. (Red Head)
- 6) 7/16" Socket Drive.

**For units that require to be mounted below the ledge please refer to the following instructions:**

**Step #1)** If the Insert Filter has not been pre-cut, you will need to measure the Inside dimensions of the catch basin walls to determine the flange size you will need. It should be 1/2" smaller than your I.D. For example, if the Inside Dimensions are 24"X24" you will need to cut your flanges to be 23.5"X23.5".

For round catch basins, measure the inside dimension then cut the filter flange 1/2" Dia., less, than the ID, then apply bulb gasket. Example: 24" Dia. ID, Cut Insert flange to 23.5" Dia.

#### Support Bracket mounting

Determine where the support brackets will need to be placed in the catch basin for best support. To help you do this, place the filter into the catch basin and mark where the center of the support should be. Support brackets should be evenly positioned for filter support. The top of the Insert Filter should rest 2" to 4" below the bottom of the grate.

Using anchor bolts, attach the corner brackets to the inside walls of the catch basin using a hammer drill with 1/4" bit. Make sure anchor bolts are as flush as possible to inside wall. Once the bracket are in place, place Insert Filter into catch basin and place grate back on catch basin.

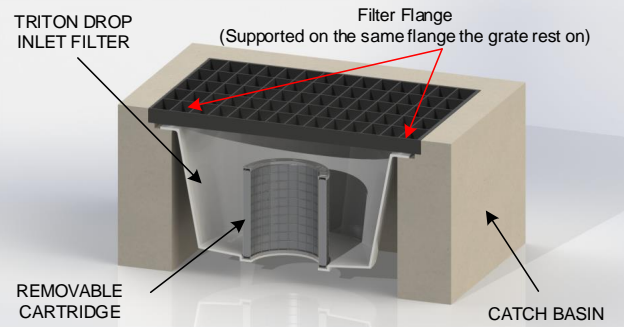
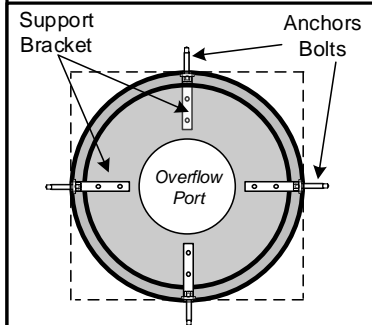
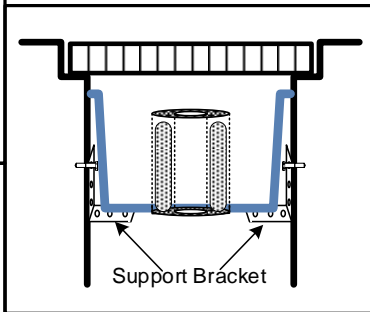

**MADE IN  
USA**

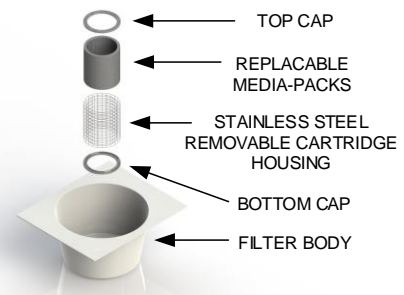



**Revel Environmental Manufacturing Inc.**

sales@remfilters.com (888) 526-4736 Lic. No. 857410  
 Northern California 960-B Detroit Avenue Concord, California 94518 P: (925) 676-4736 F: (925) 676-8676  
 Southern California 2110 South Grand Avenue Santa Ana, California 92705 P: (714) 557-2676 F: (714) 557-2679

**INSTALLATION INSTRUCTIONS FOR THE TRITON MODEL: TOP HAT (ROUND) – PERF - FTC**  
*(Designed for Square and Round catch basins and other applications)*

**Step 1)** Filter base plate flanges may need to be trimmed to fit into the throat of the catch basin. For example if the ID or inside throat of the catch basin is 24" Dia., you will want to trim the flanges down to 23.5" Dia. (Taking just a ½" off the dia.) You will then attach the bulb gasket to the outer edge of base plate. This bulb gasket will help seal any gap between the base plate and the inside wall of the catch basin. The gasket is designed to give the base plate a snug fit when installed. Some base plates may be pre-trimmed and ready for installation.

**Step 2)** Depending upon the filters cartridge configuration the support brackets will vary with the height of each cartridge height. For the 8" Tall Cartridges, the brackets should be mounted 10" or more below the grate seat. For 16" Tall Cartridges, mounting brackets should be at least 19" or more below the grate seat (See attached Side View illustration below).

**Step 3)** Attach support brackets (Corner and slotted angle, if applicable) to the catch basin throat wall on four to eight sides equally spaced using anchor bolts. Attach slotted angle crossbars for larger catch basins (see Top View illustration below).

**Step 4)** Install filter base plate first without cartridge attached. Once a tight fit along the inside diameter of the catch basin is obtained, attach the cartridge and replace grate.

**Note:** For catch basins that may have a tighter throat due to the frame and grate or other obstruction near the top, the filter base plate may come in two sections that can be un-assembled, which will allow the base plate to be re-assembled below this area. These parts will come assembled, so that you know how they should look like when installed.

If you need further assistance please call us direct at **(888) 526-4736** or email us your questions at: **Sales@remfilters.com**

**TOOLS REQUIRED:**

- 1) Skil saw.
- 2) Snips.
- 3) Hammer Drill, with ¼" masonry drill bit.
- 4) Hammer.
- 5) ¼" X 2" or 3" Concrete Anchors. i.e. (Red Head)
- 6) 7/16" Socket Drive.

**Side View Of Top Hat Filter**

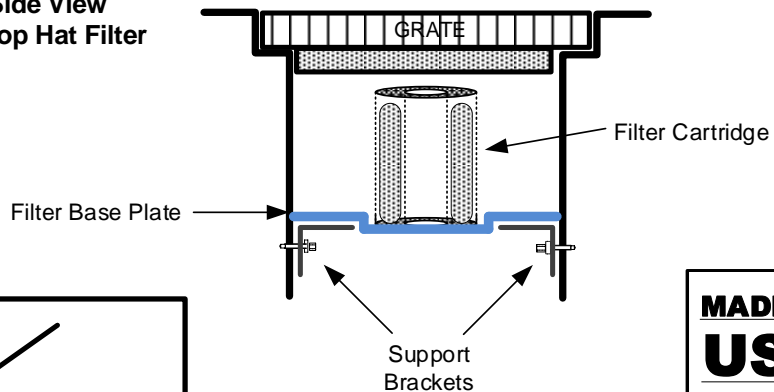

**Mounting Brackets**

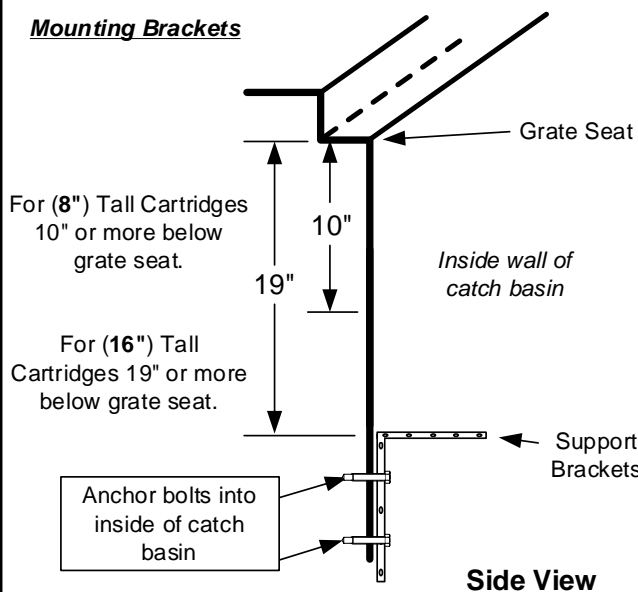

**Top View Of mounting brackets**

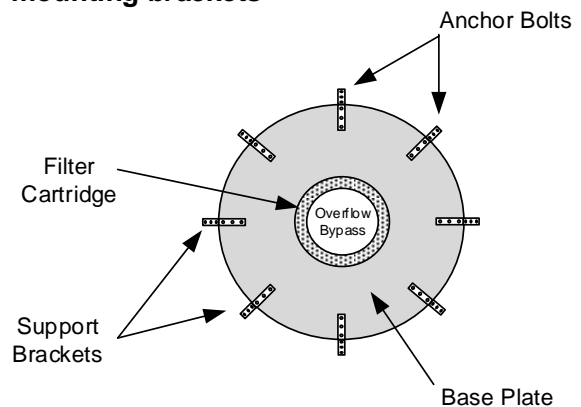



**Revel Environmental Manufacturing Inc.**

sales@remfilters.com (888) 526-4736 Lic. No. 857410  
 Northern California 960-B Detroit Avenue Concord, California 94518 P: (925) 676-4736 F: (925) 676-8676  
 Southern California 2110 South Grand Avenue Santa Ana, California 92705 P: (714) 557-2676 F: (714) 557-2679

**INSTALLATION INSTRUCTIONS FOR THE TRITON MODEL: TOP HAT (SQAURE) – PERF - FTC (Designed for Square and Round catch basins and other applications)**

**Step 1)** Filter base plate flanges may need to be trimmed to fit into the throat of the catch basin. For example if the ID or inside throat of the catch basin is 24" X 24", you will want to trim the flanges down to 23" X 23". You will then attach the bulb gasket to the outer edge of base plate. This bulb gasket will help seal any gap between the base plate and the inside wall of the catch basin. The gasket is designed to give the base plate a snug fit when installed. Some base plates may be pre-trimmed and ready for installation.

**Step 2)** Depending upon the filters cartridge configuration the support brackets will vary with the height of each cartridge height. For the 8" Tall Cartridges, the brackets should be mounted 10" or more below the grate seat. For 16" Tall Cartridges, mounting brackets should be at least 19" or more below the grate seat (See attached Side View illustration below).

**Step 3)** Attach support brackets (Corner and slotted angle, if applicable) to the catch basin throat wall on four to eight sides equally spaced using anchor bolts. Attach slotted angle crossbars for larger catch basins (see Top View illustration below).

**Step 4)** Install filter base plate first without cartridge attached. Once a tight fit along the inside diameter of the catch basin is obtained, attach the cartridge and replace grate.

**Note:** For catch basins that may have a tighter throat due to the frame and grate or other obstruction near the top, the filter base plate may come in two sections that can be un-assembled, which will allow the base plate to be re-assembled below this area. These parts will come assembled, so that you know how they should look like when installed.

If you need further assistance please call us direct at (888) 526-4736 or email us your questions at: [Sales@remfilters.com](mailto:Sales@remfilters.com)

**TOOLS REQUIRED:**

- 1) Skil saw.
- 2) Snips.
- 3) Hammer Drill, with ¼" masonry drill bit.
- 4) Hammer.
- 5) ¼" X 2" or 3" Concrete Anchors. i.e. (Red Head)
- 6) 7/16" Socket Drive.

**Side View Of Top Hat Filter**

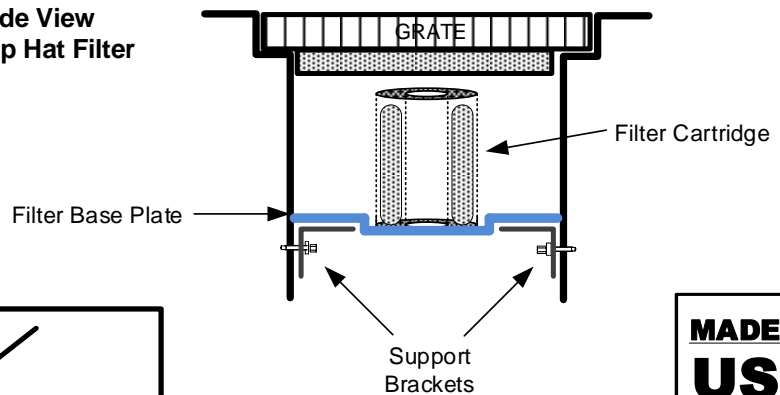

**MADE IN USA**

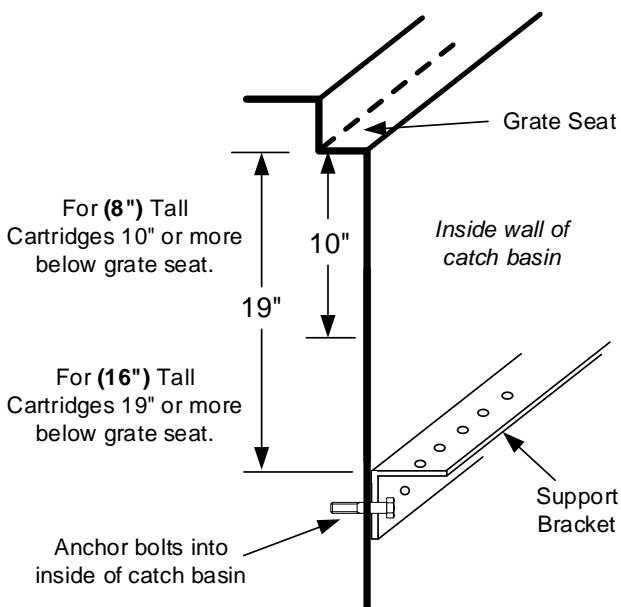

**Top View Of mounting brackets**

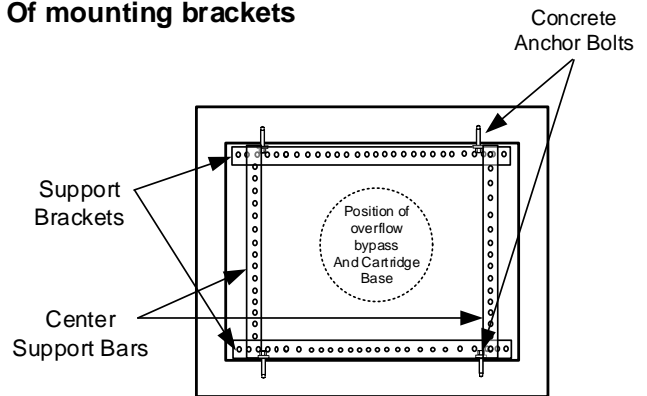



**Revel Environmental Manufacturing Inc.**

sales@remfilters.com (888) 526-4736 Lic. No. 857410  
 Northern California 960-B Detroit Avenue Concord, California 94518 P: (925) 676-4736 F: (925) 676-8676  
 Southern California 2110 South Grand Avenue Santa Ana, California 92705 P: (714) 557-2676 F: (714) 557-2679

**INSTALLATION INSTRUCTIONS FOR THE TRITON MODEL: CURB INLET - PERF - FTC**

**Step 1)** While inside of the curb inlet catch basin, starting from the left side wall to the right side wall of the curb inlet catch (while facing the street) Place Curb Inlet Filter 2" to 3" below the start of the inside vertical wall. Mark the height on the wall.

Note: If the curb inlet is larger than 3.5', you will be using additional section of filter. Joint Couplings will also be supplied to connect the section together (See Figure #3) Each filter section should come with two Cradle Brackets.

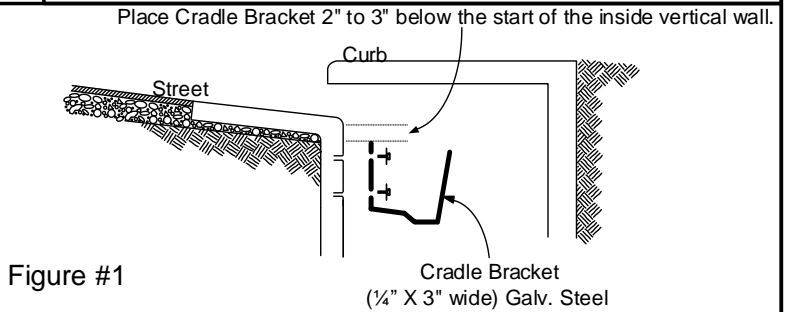

**Step 2)** Determine where the Cradle Brackets are to be placed horizontally along the inside wall. The bracket should be placed in between the windows of the curb inlet filter. For a 2' Curb Inlet section with only one window, the brackets will go on the two ends. (They should not block any of the open areas of the windows. Having the cradle brackets in position against the wall, mark the location using the existing mounting holes in the bracket as a template. These are where the holes are to be drilled to mount the brackets. Drill two holes per bracket using 1/4" masonry drill bits to install the concrete anchors. Secure cradle brackets to wall using 7/16" socket driver.

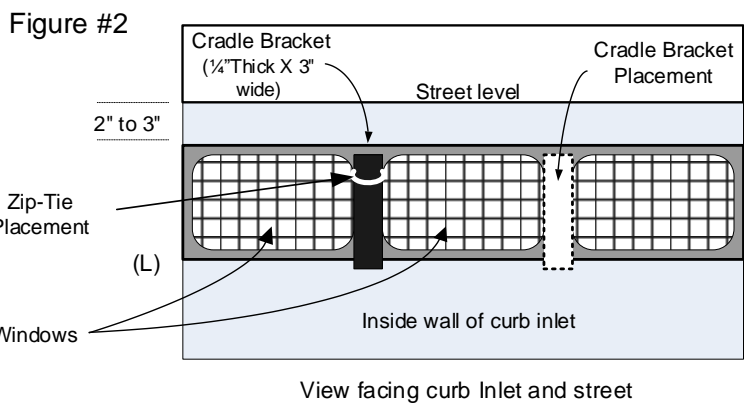

**Step 3)** Once the two cradle brackets are installed, place the Curb Inlet Filter into the cradle brackets. Attach zip ties around cradle brackets and filter.

**Step 4)** When adding adjacent sections, duplicate steps #1, #2, and #3, installing from left to right making sure all sections are at the same height. After installing the first two sections, place the black ABS Joint Coupling (Provided) into both adjoining filter ends, then lock coupling into place by using set screws (pre-drilled into coupling)

If you need further assistance please call us direct at (888) 526-4736 or email us your questions at: [Sales@remfilters.com](mailto:Sales@remfilters.com)

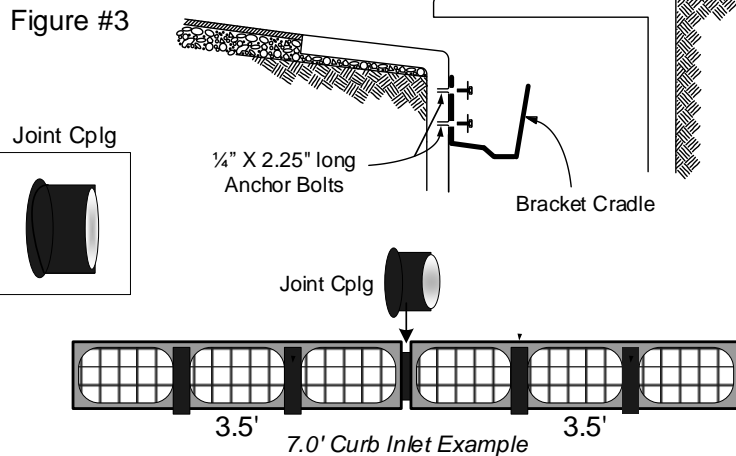

**MADE IN USA**



**Revel Environmental Manufacturing Inc.**

sales@remfilters.com (888) 526-4736 Lic. No. 857410  
 Northern California 960-B Detroit Avenue Concord, California 94518 P: (925) 676-4736 F: (925) 676-8676  
 Southern California 2110 South Grand Avenue Santa Ana, California 92705 P: (714) 557-2676 F: (714) 557-2679

**INSTALLATION INSTRUCTIONS FOR THE TRITON MODEL: AREA DRAINS – PERF - FTC**

**Note:** Area Drain Filters have been designed to be installed in a variety of different applications. Most common are exit pipes that exit vertically through a catch basin or other receiving vessel. There are two ways of securing Area Drain Filter into position.

**Option A)** If filter has been designed using a boot to connect to catch basin, it is simply pushed into place like a compression fitting. Before doing so, clean the bottom of the catch basin where the filter will be placed. Note: confirmation of exit pipe size is necessary so that the Area Drain Filter is fitted with the correct boot size.

**Option B)** If filter has been designed using a tab mounting system, place Area Drain Filter directly over exit pipe and center. Make sure to clean the bottom of the catch basin where the filter will be placed first. Using a hammer drill with 1/4" masonry drill bit, drill through existing mounting plates pre-drilled holes that are attached to both the bottom and sides of the Area Drain Filter. Hammer in anchor bolt (Red Head's), place washer over plate, then tighten down with nut using a 7/16" socket drive.

If you need further assistance please call us direct at **(888) 526-4736** or email us your questions at: **Sales@remfilters.com**

**TOOLS REQUIRED:**

- 1) Hammer Drill, with 1/4" masonry drill bit.
- 2) Hammer.
- 3) 1/4" X 2" or 3" Concrete Anchors. i.e. (Red Head)
- 4) 7/16" Socket Drive.

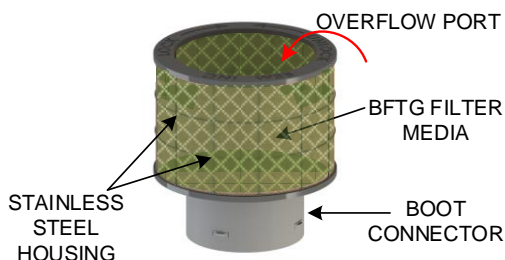

Figure #1

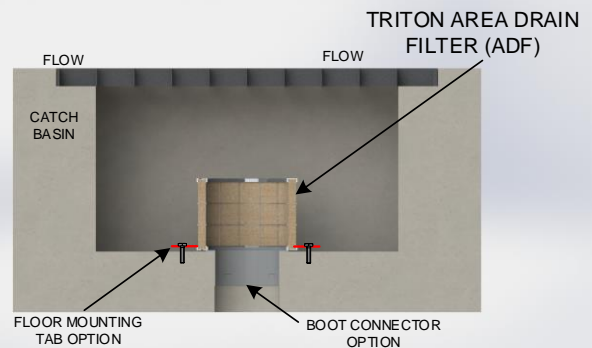

Figure #2

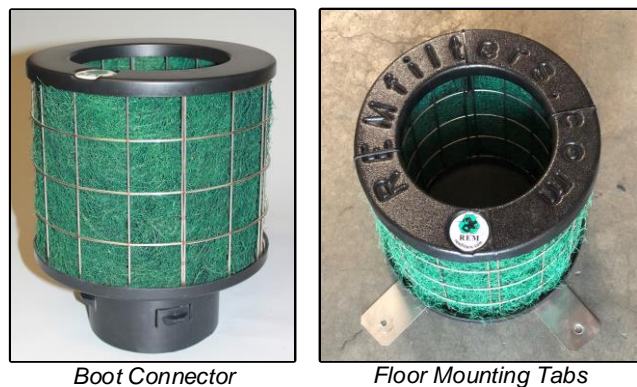
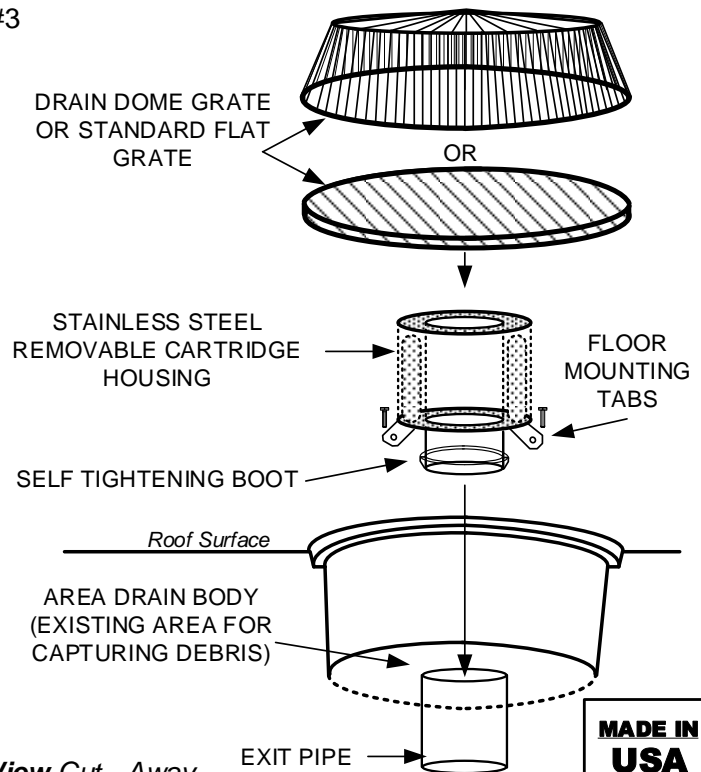

Figure #3



Side View Cut - Away



**Revel Environmental Manufacturing Inc.**

sales@remfilters.com (888) 526-4736 Lic. No. 857410  
 Northern California 960-B Detroit Avenue Concord, California 94518 P: (925) 676-4736 F: (925) 676-8676  
 Southern California 2110 South Grand Avenue Santa Ana, California 92705 P: (714) 557-2676 F: (714) 557-2679

**INSTALLATION INSTRUCTIONS FOR THE TRITON MODEL: TDAM – PERF - FTC**

**Step 1)** TDAM's are to be placed every 3' to 4' from one another unless otherwise specified, (See Figure #3). (TDAM's next to exiting pipe of trench drain should be placed 4" to 6" from the exit), (See Figure #2) Some trenches may have exit pipes at both ends or in the middle of the trench. Use the same instructions for each. For middle exiting pipes, place one TDAM on each side of exit pipe, 4" to 6" from exit pipe, (See Figure #2).

**Step 2)** After deciding placement of TDAM's, Clean any sediment or debris from location. Slide TDAM into trench drain, until it reaches the bottom of trench floor. Make sure to place additional gasket in area's where there are gaps or where water may try to bypass the TDAM.

**Step 3)** Once in position, using a hammer drill with 1/4" masonry drill bit, drill through existing mounting plate pre-drilled holes that are attached to bottom of TDAM. Hammer in anchor bolt (Red Head), place washer over plate, then tighten down with nut. Some units may require the use of side mounting tabs as well.

**Note:** Some TDAM's may come with two mounting plates per TDAM.

If you need further assistance please call us direct at **(888) 526-4736** or email us your questions at: **Sales@remfilters.com**

**TOOLS REQUIRED:**

- 1) Hammer Drill, with 1/4" masonry drill bit.
- 2) Hammer.
- 3) 1/4" X 2" or 3" Concrete Anchors. i.e. (Red Head)
- 4) 7/16" Socket Drive.

Figure #1

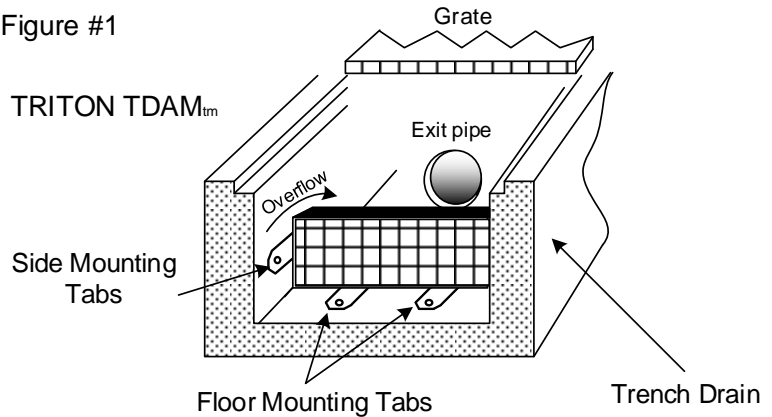

Figure #2

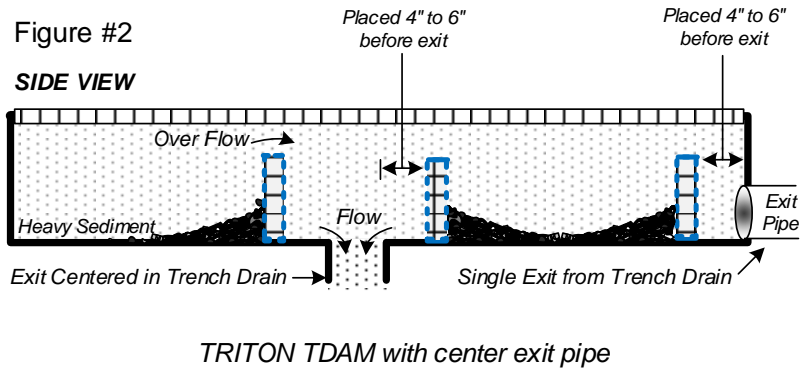
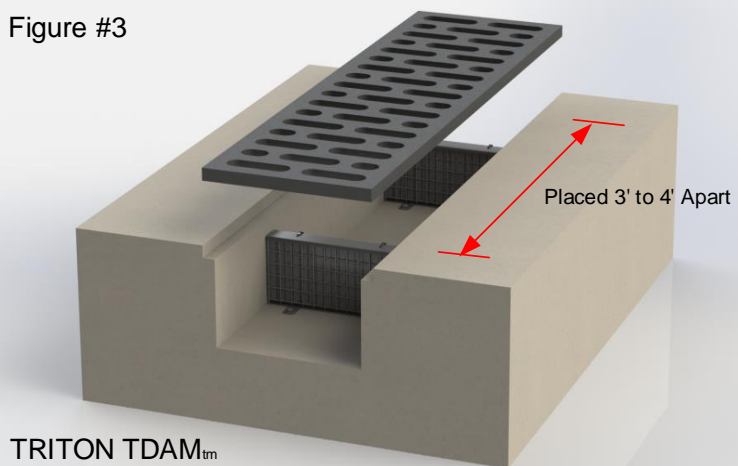

Figure #3





#### **4B: Description of installation limitations and non-standard installation procedures**

One of the common limitations found in the field are catch basin that are too shallow, or the infrastructure is not conducive for a standard Insert filter. We can filter many different types of configurations, but sometimes modifications or custom units are needed to properly capture the target contaminant. When we come across unusual drains, our approach is to always maximize the given catch basin configuration with the largest volume capturing ability. This may lead to a filter that will need to be customized to fit. Typical modifications that may be needed are trimming the devices housings, cutting down the size of the filter, or adding attachments like an extension of stainless steel or HMWPE depending on the device and model type.

#### **4C: Methods for diagnosing and correcting installation errors**

A visual assessment can be done to determine if the device has not been installed correctly. If needed, the device can simply be removed by lifting and removing the device or removing the anchor nuts and then removing the device. Proper re-installation can take place at that point. All filters should be level and firmly in place. Filters are designed to hold a large amount of trash and sediment, which requires the filters to be well supported. If there is any weakness in the support of the filter, more support will of course be needed. There should also not be any gaps where water can bypass the system during normal storm events. TRITON PERF – FTC Filters have been designed for their ease of installation. If anyone does have installation problems, they may call our offices and we will be glad to help. 1 (888) 526-4736

### **Section 5: Operation and maintenance information**

#### **5A: Device inspection procedures and frequency considerations**

Each device inspection can be done visually, remove the grate/manhole if needed and assess if the unit is damaged, at what capacity, or experienced a bypass event. REM recommends that devices not on a standard maintenance schedule be inspected 3 times per year or more if needed.

#### **5B: Maintenance frequency considerations due to capacity at various volumes**

REM recommends that devices be maintained 3 times per year, or as outlined by the governing body. It is recommended that devices do not reach more than 50% capacity without a maintenance event. This frequency is dictated by the loading capacity at each particular drain as well. If not properly maintained, devices will reach 100% capacity and begin the bypass event for debris entering the catch basin. If filters are consistently above 50% full, REM recommends additional maintenance intervals.

#### **5C: Maintenance procedures**

Secure area (Traffic and pedestrian controls, if needed). Pull grate and set aside. Remove (VAC) debris that has been captured in system. Pressure washing may also be necessary in some cases to remove certain debris. After system has been cleaned. Visually inspect filter for any damaged areas. Take a picture of the cleaned filter for your records. Fill out report if used for the given catch basin. Replace grate. Remove all traffic control devices.

#### **5D: Essential equipment and materials for proper maintenance**

The maintenance for the TRITON PERF-FTC Filters is accomplished for the most part by using an industrial vacuum truck due to the large capture capacity of the devices. Simply remove the grate and begin to remove the captured debris. The device can be brushed or sprayed off if needed. Take note of the amount of debris collected along with the condition of the device. Vacuum Truck, Grate Pick.

**5E: Description of effects of deferred maintenance**

Typical implications of deferred maintenance consist primarily of debris that will begin to bypass the device because it has reached the full capacity of its limitations. If the device has been properly installed and supported, it should continue to remain in the original placement from the initial installation.

**5F: Repair procedures for device components**

In the case that a particular component is damaged, it is advised to call our customer service department for repair or replacement options. Please call (888) 526-4736 for repair or replacement issues.

**Section 6: Vector Control Accessibility**

**6A: Date of device submittal to MVCAC**

Device Fact Sheet was submitted to MVCAC on 11/23/2021

Device Fact Sheet was approved by MVCAC on 12/20/2021

**6B: Description or drawing that demonstrates vector control personnel accessibility**

Drawings continued on next page.

*This Section Intentionally Left Blank*

# REM Inc.

## VECTOR CONTROL ACCESSIBILITY

For Models:

INSERT-PERF-FTC CPS-PERF-FTC  
 TOP HAT-PERF-FTC AREA DRAINS-PERF-FTC  
 CURB INLET-PERF-FTC TDAM-PERF-FTC

**\*\*REM TRITON PERF Devices have no moving or swinging parts for abatement access. All devices allow a free and clear access to the bottom of catch basin and lateral lines below, as well as notched bottoms to prevent standing water.**

For Insert Filters, access to bottom of catch basin is done through filters Overflow Port. Clear and direct opening access.

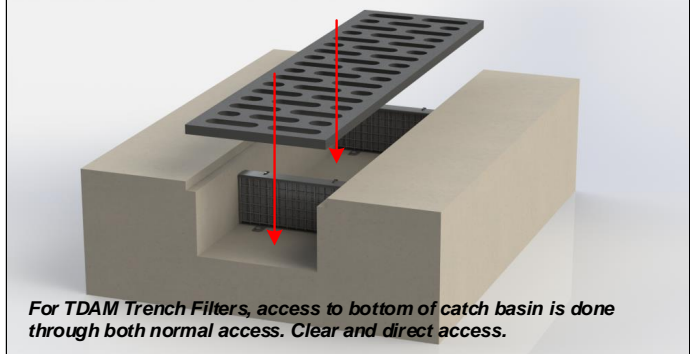
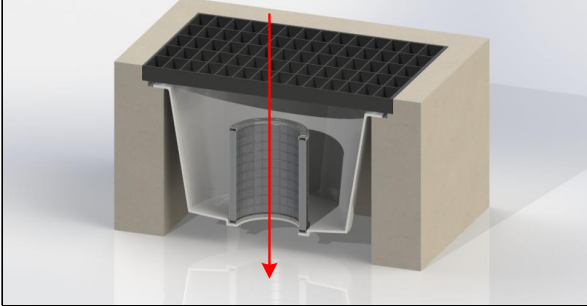

For TDAM Trench Filters, access to bottom of catch basin is done through both normal access. Clear and direct access.

For Curb Inlet Filters, access to bottom of catch basin can be done through the curb opening or the manhole cover on the curb.

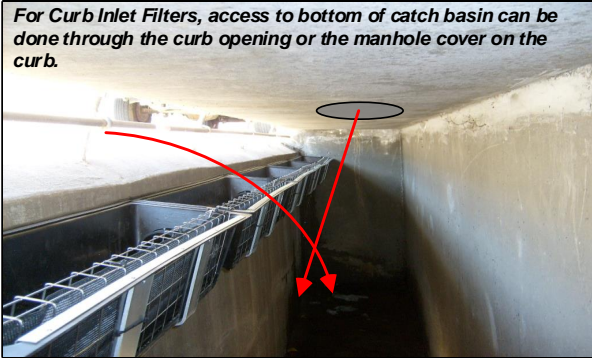

For Top Hat Filters, access to bottom of catch basin is done through filters Overflow Port. Clear and direct opening access.

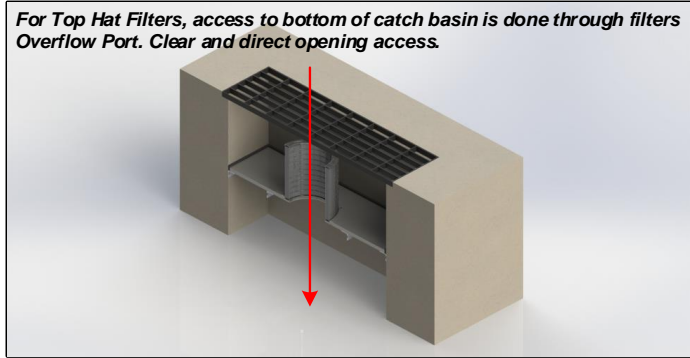

For CPS Filters, access to bottom of catch basin is done through optional Deflector Plate with Elevated Vector Access. Clear and direct opening access.

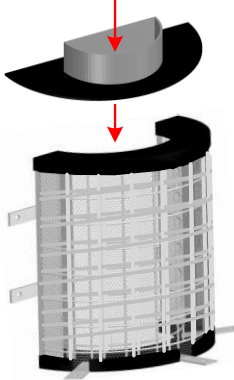

For Area Drain Filters, access to bottom of catch basin is done through both normal access and filter Overflow Port. Clear and direct opening access.

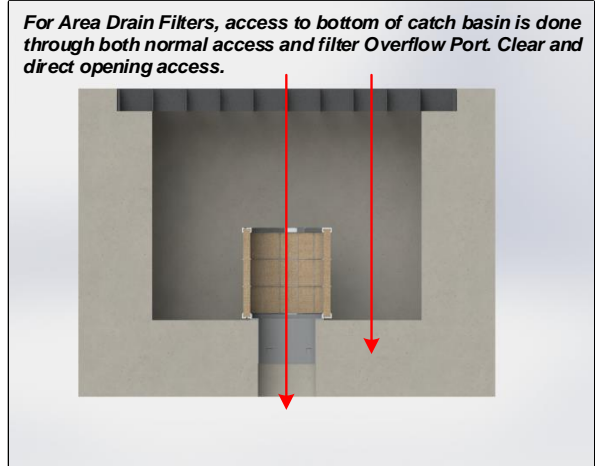

**Revel Environmental Manufacturing Inc.**

sales@remfilters.com (888) 526-4736 Lic. No. 857410

Northern California  
 960-B Detroit Avenue  
 Concord, California 94518  
 P: (925) 676-4736  
 F: (925) 676-8676

Southern California  
 2110 South Grand Avenue  
 Santa Ana, California 92705  
 P: (714) 557-2676  
 F: (714) 557-2679



**REM Inc.**  
**VECTOR CONTROL ACCESSIBILITY**

**For Models: INSERT-PERF-FTC**

*\*\*REM TRITON PERF Devices have no moving or swinging parts for abatement access. All devices allow a free and clear access to the bottom of catch basin and lateral lines below, as well as notched bottoms to prevent standing water.*

*For Insert Filters, access to bottom of catch basin is done through filters Overflow Port. Clear and direct opening access.*

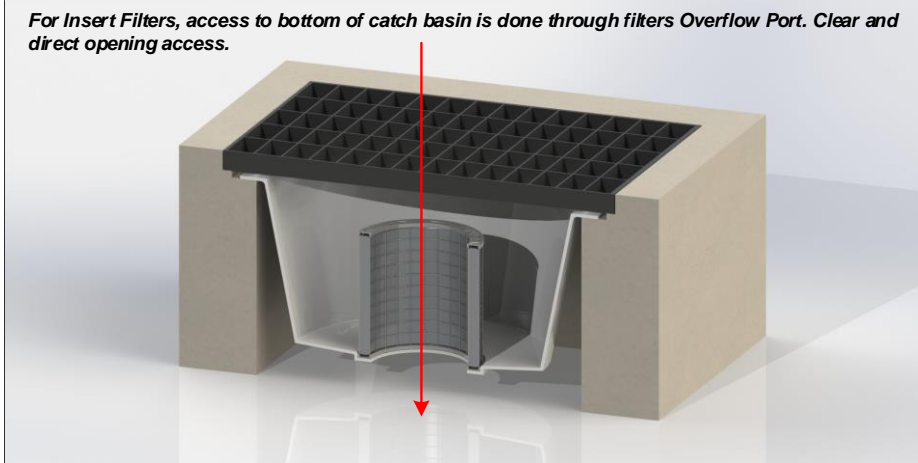

Easy Access to bottom of catch basins

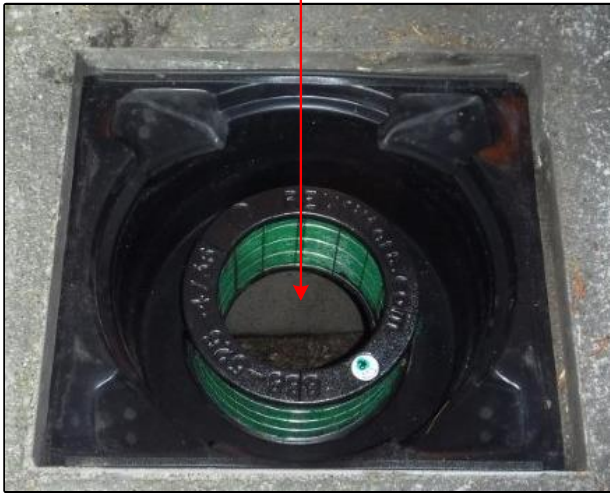

**TRITON INSERT FILTER SERIES**

*Triton Insert Filters*

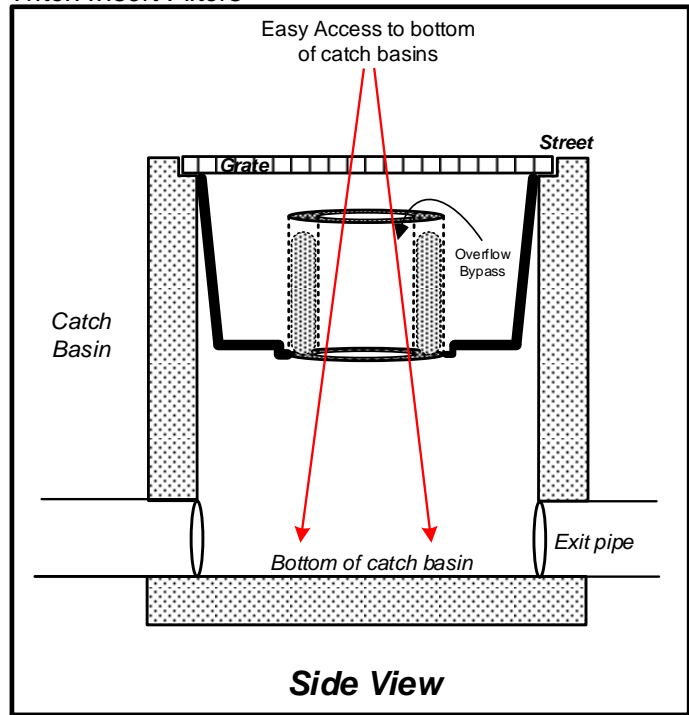

**Side View**



**Revel Environmental Manufacturing Inc.**

sales@remfilters.com (888) 526-4736 Lic. No. 857410

Northern California  
 960-B Detroit Avenue  
 Concord, California 94518  
 P: (925) 676-4736  
 F: (925) 676-8676

Southern California  
 2110 South Grand Avenue  
 Santa Ana, California 92705  
 P: (714) 557-2676  
 F: (714) 557-2679



**REM Inc.**  
**VECTOR CONTROL ACCESSIBILITY**

**For Models: TOP HAT-PERF-FTC**

*\*\*REM TRITON PERF Devices have no moving or swinging parts for abatement access. All devices allow a free and clear access to the bottom of catch basin and lateral lines below, as well as notched bottoms to prevent standing water.*

*For Top Hat Filters, access to bottom of catch basin is done through filters Overflow Port. Clear and direct opening access.*

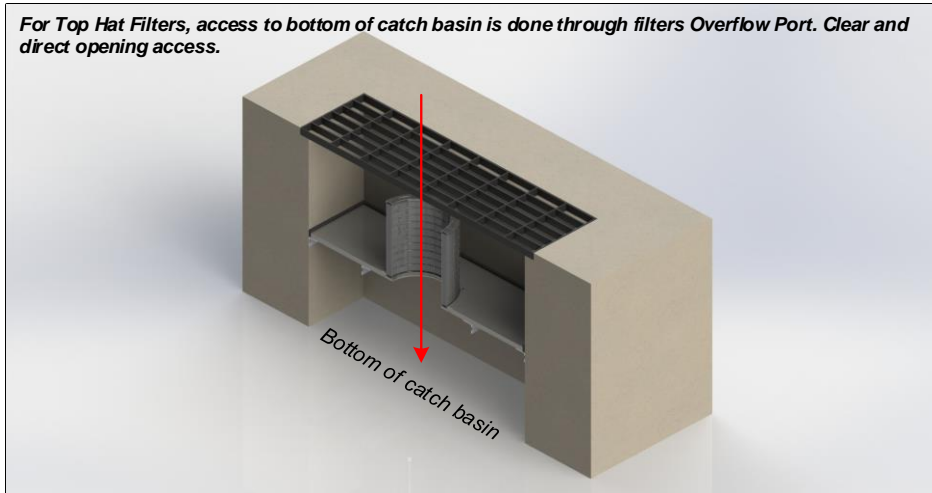

Easy Access to bottom of catch basins



**TRITON TOP HAT FILTER SERIES**

**Triton Top Hat Filters**

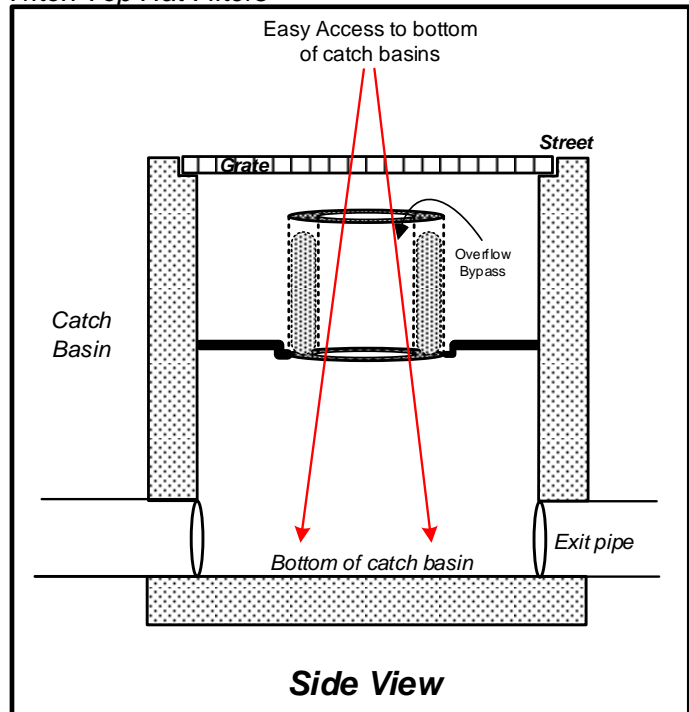

**Side View**



**Revel Environmental Manufacturing Inc.**

sales@remfilters.com (888) 526-4736 Lic. No. 857410

Northern California  
960-B Detroit Avenue  
Concord, California 94518  
P: (925) 676-4736  
F: (925) 676-8676

Southern California  
2110 South Grand Avenue  
Santa Ana, California 92705  
P: (714) 557-2676  
F: (714) 557-2679



# REM Inc.

## VECTOR CONTROL ACCESSIBILITY

**For Models: CURB INLET-PERF-FTC**

*\*\*REM TRITON PERF Devices have no moving or swinging parts for abatement access. All devices allow a free and clear access to the bottom of catch basin and lateral lines below, as well as notched bottoms to prevent standing water.*

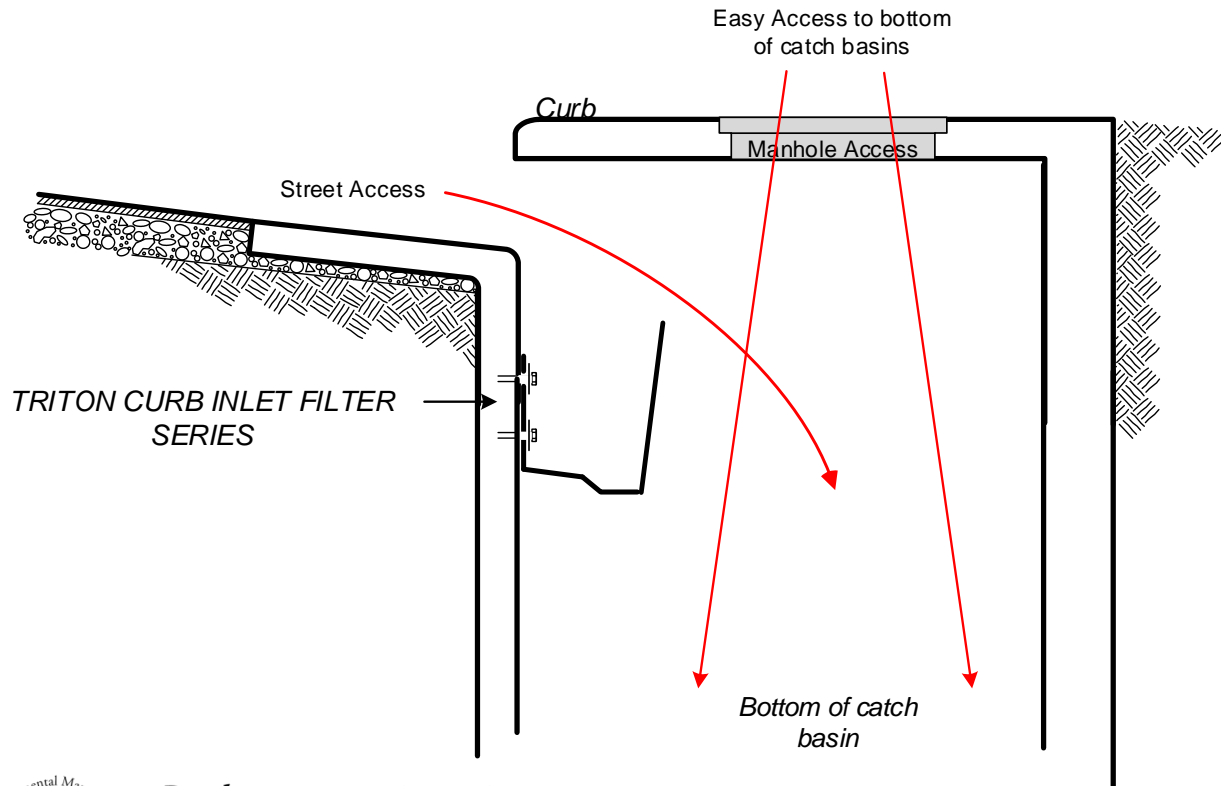
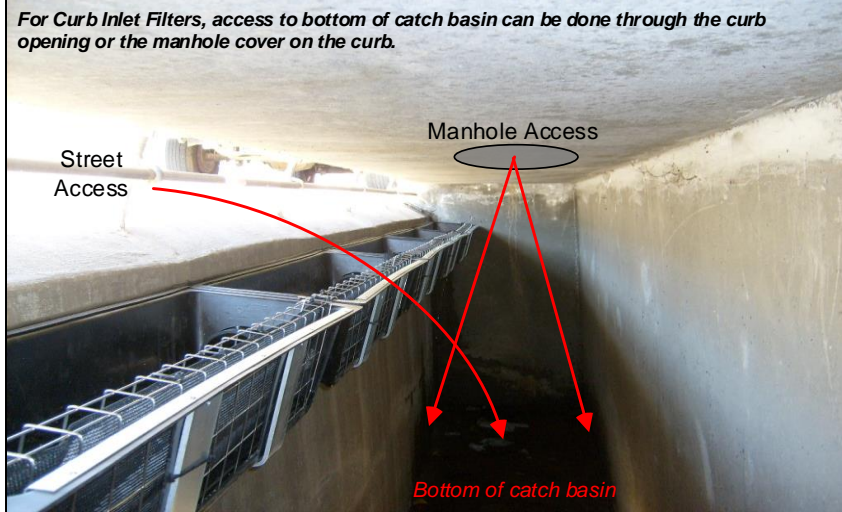

**Revel Environmental Manufacturing Inc.**  
 sales@remfilters.com (888) 526-4736 Lic. No. 857410

Northern California  
 960-B Detroit Avenue  
 Concord, California 94518  
 P: (925) 676-4736  
 F: (925) 676-8676

Southern California  
 2110 South Grand Avenue  
 Santa Ana, California 92705  
 P: (714) 557-2676  
 F: (714) 557-2679



# REM Inc.

## VECTOR CONTROL ACCESSIBILITY

**For Models: AREA DRAIN-PERF-FTC**

**\*\*REM TRITON PERF Devices have no moving or swinging parts for abatement access. All devices allow a free and clear access to the bottom of catch basin and lateral lines below, as well as notched bottoms to prevent standing water.**

For Area Drain Filters, access to bottom of catch basin is done through both normal access and filter Overflow Port. Clear and direct opening access.

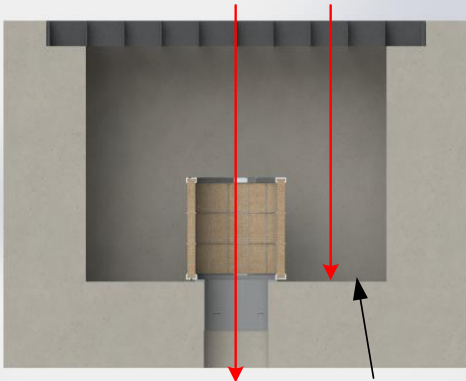

Bottom of Drain

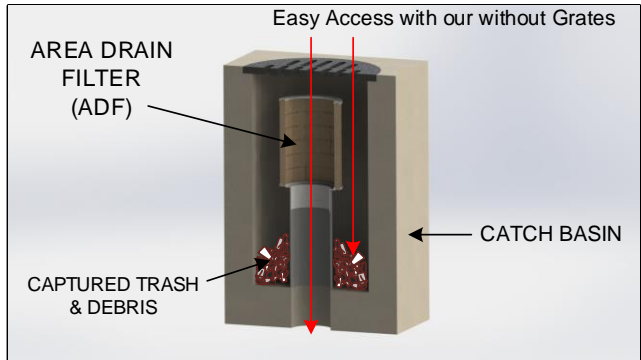

Easy access to bottom of catch basin

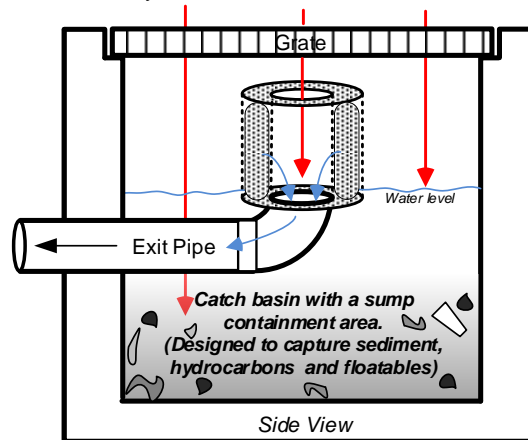

Area Drain Filter (ADF) shown in a trench drain with a vertical exit pipe.

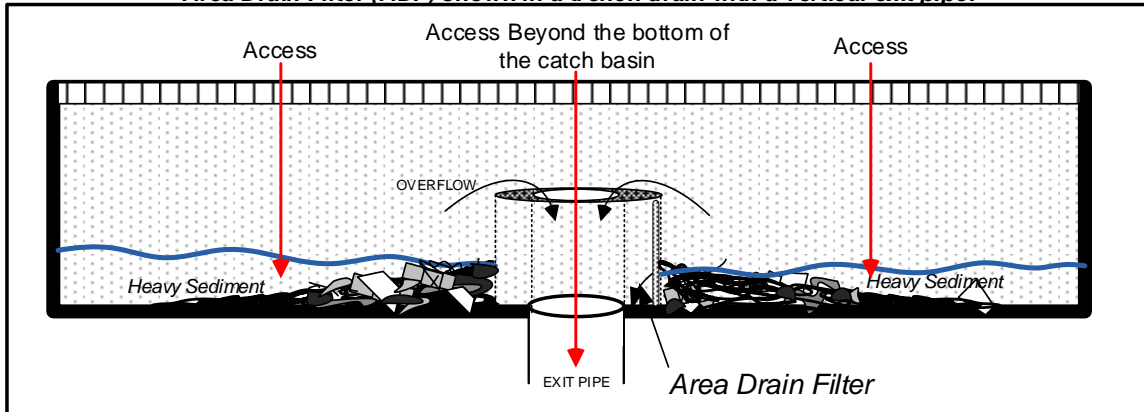

**Revel Environmental Manufacturing Inc.**

sales@remfilters.com (888) 526-4736 Lic. No. 857410

Northern California  
960-B Detroit Avenue  
Concord, California 94518  
P: (925) 676-4736  
F: (925) 676-8676

Southern California  
2110 South Grand Avenue  
Santa Ana, California 92705  
P: (714) 557-2676  
F: (714) 557-2679



# REM Inc.

## VECTOR CONTROL ACCESSIBILITY

**For Models: TDAM-PERF-FTC**

**\*\*REM TRITON PERF Devices have no moving or swinging parts for abatement access. All devices allow a free and clear access to the bottom of catch basin and lateral lines below, as well as notched bottoms to prevent standing water.**

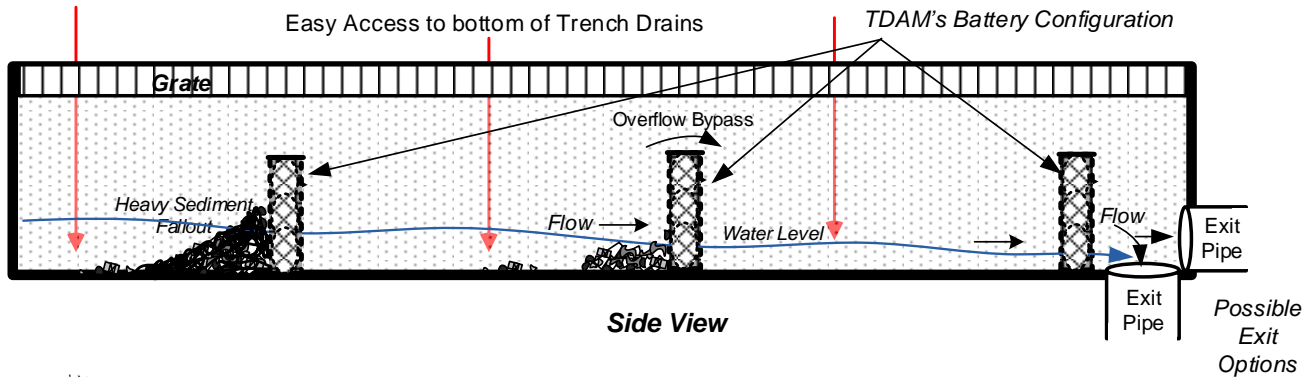
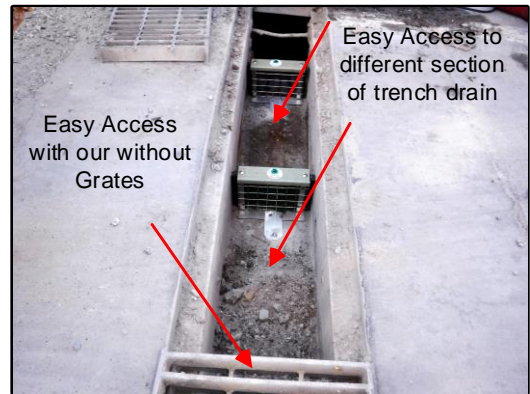
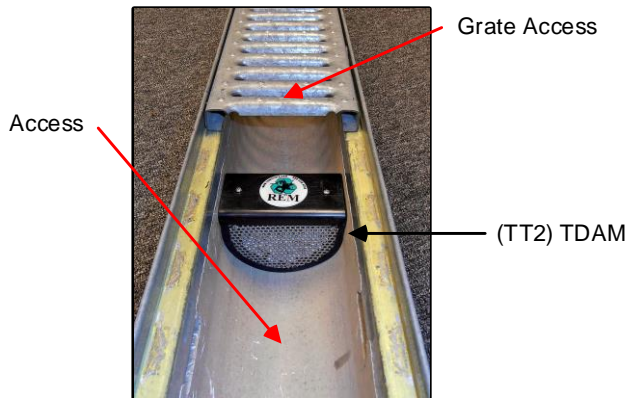
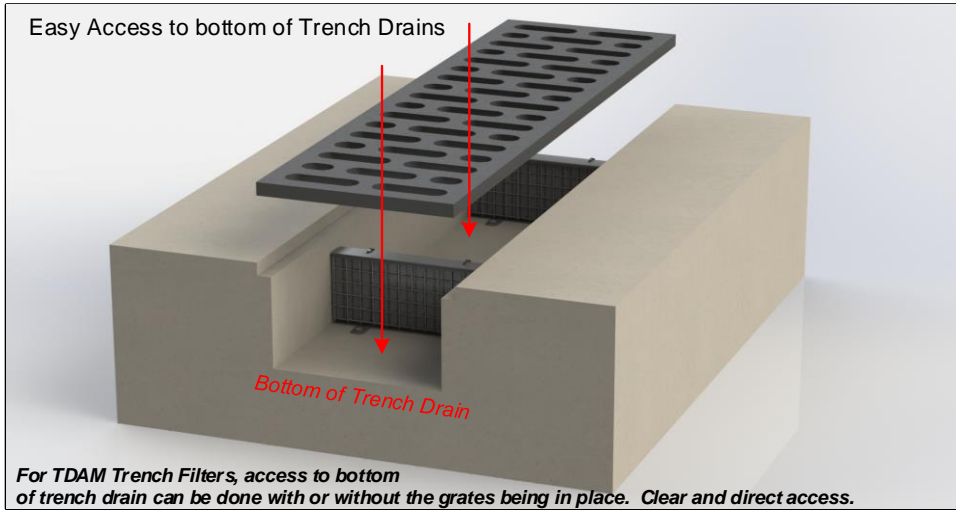

**Revel Environmental Manufacturing Inc.**

sales@remfilters.com (888) 526-4736 Lic. No. 857410

Northern California  
960-B Detroit Avenue  
Concord, California 94518  
P: (925) 676-4736  
F: (925) 676-8676

Southern California  
2110 South Grand Avenue  
Santa Ana, California 92705  
P: (714) 557-2676  
F: (714) 557-2679





## 6C: Letter of Verification from MVCAC



**MVCAC**  
Mosquito and Vector Control Association of California

One Capitol Mall, Suite 800 • Sacramento, CA 95814 • p: (916) 440-0826 • f: (916) 444-7462 • e: [mvcac@mvcac.org](mailto:mvcac@mvcac.org)

Revel Environmental Manufacturing, Inc 960 Detroit  
Ave. Suite B  
Concord, CA 94518

December 20, 2021

Dear Mr. Fleischmann,

Thank you for the submitting the Revel Environmental Manufacturing Inc. Triton PERF-FTC devices for review by the Mosquito and Vector Control Association of California pursuant to the SWRCB Trash Treatment Control Device Application Requirements. The Association has carefully reviewed the conceptual drawings for the Triton Insert PERF-FTC, Triton Top Hat PERF-FTC, Triton Curb Inlet, Triton TDam, and Triton Area Drain devices and verifies that provisions have been included in the designs that allow for full visual access to all areas for presence of standing water, and when necessary, allows for treatments of mosquitoes.

While this verification letter confirms that inspection and treatment for the purpose of minimizing mosquito production should be possible with the Revel Environmental Manufacturing Inc. Triton PERF-FTC devices as presented, it does not affect the local mosquito control agency's rights and remedies under the State Mosquito Abatement and Vector Control District Law. For example, if the installed device or the associated stormwater system infrastructure becomes a mosquito breeding source, it may be determined by a local mosquito control agency to be a public nuisance in accordance with California Health and Safety Code sections 2060-2067.

"Public nuisance" means any of the following:

1. Any property, excluding water, that has been artificially altered from its natural condition so that it now supports the development, attraction, or harborage of vectors. The presence of vectors in their developmental stages on a property is prima facie evidence that the property is a public nuisance.
2. Any water that is a breeding place for vectors. The presence of vectors in their developmental stages in the water is prima facie evidence that the water is a public nuisance.
3. Any activity that supports the development, attraction, or harborage of vectors, or that facilitates the introduction or spread of vectors. (Heal. & Saf. Code § 2002 (j).)

Declaration of a facility or property as a public nuisance may result in penalties as provided under the Health and Safety Code. Municipalities and the vendors they work with are encouraged to discuss the design, installation, and maintenance of stormwater trash capture devices with their local mosquito control agency to reduce the potential for disease transmission and public nuisance associated with mosquito production.

Sincerely,

Bob Achermann,  
MVCAC Executive Director

## **Section 7: Reliability information**

### **7A: Estimated design life of device**

Under normal operations and with the impact of large storm events, the TRITON PERF-FTC has an estimated lifespan of 20+ years. Naturally occurring elements and mineral saturation do not have a resounding effect on either the Stainless Steel, HMWPE, or ABS used in construction.

### **7B: Warranty information**

REM warrants the TRITON PERF-FTC device for 3 years after the installation date. This includes the device and material itself.

### **7C: Customer support**

For general regional assistance please contact the following REM representatives:

Marcel Sloane  
Northern California Regional Manager  
960 Detroit Ave. Suite B  
Concord, CA. 94518  
(888) 526-4736  
[Marcel@remfilters.com](mailto:Marcel@remfilters.com)

Bob Marchant  
Southern California General Manager  
2110 S. Grand Ave.  
Santa Ana, CA. 92705  
(714) 557-2676  
[Bobm@remfilters.com](mailto:Bobm@remfilters.com)

For technical and design information please contact:

Daniel Fagan  
Northern California Operations Manager  
960 Detroit Ave. Suite B  
Concord, CA. 94518  
(925) 676-4736  
[Daniel@remfilters.com](mailto:Daniel@remfilters.com)

## **Section 8: Field/Lab testing information and analysis**

All Test units were placed in HIGH trash and debris areas within Contra Costa County. Below are results from initial inspections.

\*Continued next page.

Test Unit T1

This TR3648-TH Insert was retrofitted with a TR14(16) PERF Cartridge.

Unit is located in Contra Costa County in a Downtown park and restaurant block, which is a high foot traffic and trash area.

After 2 inspections the findings were given to governing body at which point a maintenance event was coordinated and performed on the unit.

Approximately 60 gallons (13,860 cubic inches) of naturally compacted trash and debris were removed from the catch basin filter insert.



Test Unit: T1 - TR14(16) PERF Cartridge – Attached to model TR3648-TH



T1: 2 months after installation – 40% capacity



T1: 3 months after installation – 50% capacity