



May 10, 2022  
Mr. Leo Cosentini  
California State Water Resources Control Board  
Division of Water Quality  
P.O. Box 100  
Sacramento, CA 95812-0100

Dear Mr. Cosentini,

Thank you for the opportunity for Fabco Industries, Inc. to submit our application for the **Fabco ScreenBox** for certification as a Full Capture System -Trash Treatment Control Device. The Fabco ScreenBox is a catch basin insert installed at the grate frame opening of a catch basin to screen and retain any trash, debris, or particles larger than 5 mm in diameter or greater within an easily maintained metal screening basket. The Fabco ScreenBox allows for a peak flow rate equal to or greater than the peak flow of the storm drain in which it is installed. Provisions have also been made to ensure that Mosquito Vector Control personnel are easily able to inspect the device without needing to lift grates or perform confined space entry. The Fabco ScreenBox has been installed and successfully protects waterways in stormwater infrastructure projects nationwide, including in California within the cities of San Diego, Chula Vista, and Escondido.

Within our application below we have spoken to each of the submittal requirements within the Trash Treatment Control Device Certification and Fact Sheet Update Requirements and maintained the requested layout.

Thank you again for your consideration and time taken to review our application. If any additional information is needed, please do not hesitate to contact myself Hilme Athar or our V.P. of Engineering, John Peters. Both of our contact information can be found within the application below.

Sincere regards,

A handwritten signature in black ink that reads "Hilme Athar". The signature is written in a cursive, flowing style.

Hilme Athar  
Sales Engineer  
24 Central Drive  
Farmingdale, NY 11735  
(631) 393-6024  
[hathar@fabco-industries.com](mailto:hathar@fabco-industries.com)

## 1. R5 Cover Letter

### 1.A. Device Name and General Description

The Fabco ScreenBox is a full capture trash screening device designed and manufactured by Fabco Industries. The device is a catch basin insert installed at the grate frame opening of a catch basin to screen and capture any trash or particles 5 mm or greater in diameter, within an easily maintained aluminum basket. The Fabco ScreenBox is comprised of an adjustable aluminum mounting frame and an aluminum basket with perforated metal screens for filtration of trash. The device is designed to be durable, lightweight, and easily installed.

### 1.B. Applicant's Contact Information and Location

#### Owner Information:

John Peters  
V.P. of Engineering  
24 Central Drive  
Farmingdale, NY 11735  
(631) 393-6024  
[johnp@fabco-industries.com](mailto:johnp@fabco-industries.com)

#### Authorized Representative(s) Contact Information:

Rob Williamson  
Manager of Sales & Engineering  
24 Central Drive  
Farmingdale, NY 11735  
(631) 393-6024  
[rwilliamson@fabco-industries.com](mailto:rwilliamson@fabco-industries.com)

Hilme Athar  
Sales Engineer  
24 Central Drive  
Farmingdale, NY 11735  
(631) 393-6024  
[hathar@fabco-industries.com](mailto:hathar@fabco-industries.com)

### 1.C. Manufacturer's Website Page for Device

<https://fabco-industries.com/stormwater-catch-basin-filter-insert-basket/>

### 1.D. Device's Manufacturing Location

Fabco Industries, Inc.  
24 Central Drive  
Farmingdale, NY 11735  
(631) 393-6024

### 1.E. Brief Summary of Field/Lab Testing Results

The Fabco ScreenBox is designed to capture trash using screening windows found on the basket portion of the device. The screen material is perforated aluminum sheet metal with  $\text{Ø}3/16''$  (approximately  $\text{Ø}4.8$  mm) round holes. The entire design flow must flow through the perforated metal so all trash 5 mm and greater in diameter is trapped from the peak design flow. No lab testing is required as all trash 5 mm and greater in diameter are physically blocked by the screening material from flowing forward. Existing installations of the Fabco ScreenBox, including project sites within California, have yielded only positive results. All filtered flow rates reported in the hydraulic capacity table (Section 3.C.) have been calculated using the percent open area of the

perforated metal, head pressures measured to the bypass of the device, and a standard coefficient of discharge of 0.62 for the orifice equation.

**1.F. Brief Summary of Device Limitations, and Operational, Sizing, and Maintenance Considerations**

The Fabco ScreenBox is available in standard sizes for various grate inlet sizes. Custom units are also regularly engineered to meet site-specific design flows and dimensional requirements. Accessibility within an installation site is taken into high consideration and all designs ensure the greatest ease of installation at each site. Mandatory vector control corner fillers are utilized and required for all projects in California to allow access to the bottom of a catch basin by Mosquito Vector Control Personnel without the need for lifting grates or confined space entry.

Regular maintenance is necessary for the Fabco ScreenBox to function properly. Fabco typically suggests maintenance be scheduled twice a year, but true necessary maintenance frequency will depend on site-specific conditions. The applicable Municipal Stormwater permit may specify more frequent maintenance intervals as well. The filtered flowrate of the Fabco ScreenBox is designed to completely screen at least the trash treatment peak design flow. Fabco ScreenBox units are sized to trap trash 5 mm or greater in diameter for flows generated from the 1 year, 1 hour storm. In addition, Fabco ScreenBox units are sized to maintain hydraulic capacity prior to required maintenance as specified in the applicable Municipal Stormwater permit. Fabco Industries recommends use of a vacuum truck to most easily clean captured trash within the catch basin insert.

**1.G. Description, or List of Locations, where Device has been installed**

Fabco ScreenBox units have been installed for several stormwater management projects throughout California and nationally. Below are some example current install sites within the state of California:

Current Install Sites	
Project	Contact
Old Town Transit Center, San Diego, CA	Kevin Rettig Director of Operations California Filtration Specialists LLC Phone: 858-705-6483 Email: <a href="mailto:kevin@cafiltrationspecialists.com">kevin@cafiltrationspecialists.com</a>
Sunnyview Avenue, Visalia, CA	
For CP Kelco in San Diego, CA	

## 1.H. Certification

*I certify under penalty of law that this document and all attachments were prepared under my direction or supervision in accordance with a system designed to assure that qualified personnel properly gather and evaluate the information submitted. Based on my inquiry of the person or persons that manage the system or those persons directly responsible for gathering the information, to the best of my knowledge and belief, the information submitted is, true, accurate, and complete. I am aware that there are significant penalties for submitting false information, including the possibility of fine and imprisonment for knowing violations.*

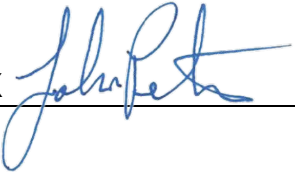
X  \_\_\_\_\_

John Peters  
V.P. of Engineering  
(631) 393-6024  
[johnp@fabco-industries.com](mailto:johnp@fabco-industries.com)

## 2. Table of Contents

<b>1. Cover Letter</b> .....	<b>1</b>
1.A. Device Name and General Description .....	1
1.B. Applicant’s Contact Information and Location .....	1
1.C. Manufacturer’s Website Page for Device .....	1
1.D. Device’s Manufacturing Location .....	1
1.E. Brief Summary of Field/Lab Testing Results .....	1
1.F. Brief Summary of Device Limitations, and Operational, Sizing, and Maintenance Considerations .....	2
1.G. Description, or List of Locations, where Device has been installed .....	2
1.H. Certification .....	3
<b>2. Table of Contents</b> .....	<b>4</b>
<b>3. Physical Description</b> .....	<b>5</b>
3.A. Trash Capture .....	5
3.B. Peak Flows/Trash Volumes .....	5
3.C. Hydraulic Capacity .....	6
3.D. Comparison Table .....	7
3.E. Design Drawings .....	7
3.F. Alternative Configurations .....	7
3.G. Internal Bypass .....	7
3.H. Previously Trapped Trash .....	7
3.I. Calibration Feature .....	7
3.J. Photos .....	8
3.K. Material Type .....	8
3.L. Design Life .....	9
<b>4. Installation Guidance</b> .....	<b>9</b>
4.A. Standard Device Installation Procedures and Considerations.....	9
4.B. Description of Device Installation Limitations and Non-Standard Device Installation Procedure .....	9
4.C. Methods for Diagnosing and Correcting Installation Errors .....	9
<b>5. Operation and Maintenance Information</b> .....	<b>10</b>
5.A. Inspection Procedures and Frequency Considerations .....	10
5.B. Description of Maintenance Frequency Considerations .....	10
5.C. Maintenance Procedures .....	11
5.D. Essential Equipment and Materials for Proper Maintenance Activities .....	11
5.E. Description of the Effects of Deferred Maintenance on Device Structural Integrity, Performance, Odors, etc. ....	11
5.F. Repair Procedures for Device’s Structural and Screening Components .....	11
<b>6. Vector Control Accessibility</b> .....	<b>12</b>
6.A. Date of Application Submittal to Mosquito Vector Control Association .....	12
6.B. Description of Access for Vector Control Personnel .....	12
6.C. Mosquito Vector Control Association of California Letter of Verification .....	13
<b>7. Reliability Information</b> .....	<b>13</b>
7.A. Estimated Design Life of Device Components before Major Overhaul .....	13
7.B. Warranty Information .....	13
7.C. Customer Support Information .....	14
<b>8. Field/Lab Testing Information and Analysis</b> .....	<b>14</b>
APPENDIX A .....	15
APPENDIX B .....	16

### 3. Physical Description

---

#### 3.A. Trash Capture

The primary component of the Fabco ScreenBox that captures trash 5 mm or greater in diameter is the screening basket of the device. The screens of the basket are perforated aluminum sheet metal with  $\text{Ø}3/16''$  (approximately  $\text{Ø}4.8$  mm) round openings. During a storm event, the entire design flow is directed downwards through the screen windows, trapping any trash particles 5mm or greater in diameter within the device and allowing water to flow past into the bottom of the catch basin. Below is a representative image of a Fabco ScreenBox unit as well as a descriptive feature list of all components comprising the device:

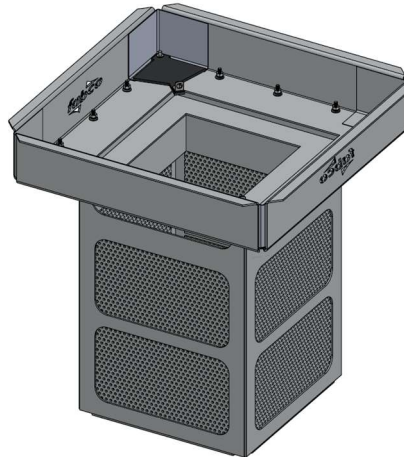

- The Fabco ScreenBox aluminum mounting frame consists of four slotted flanges, a top plate, and corner filler pieces (two of which are mandatory vector control corner fillers).
- The aluminum components are fabricated from 1/8" thick aluminum sheet metal, except the screens and corner fillers which are fabricated from 1/16" thick aluminum sheet metal.
- The vector control corner fillers utilize a neoprene rubber flap which can be pulled open upwards to access a 3" diameter opening allowing visual and physical access to the bottom of a catch basin.
- Each flange is secured to the top plate using stainless steel carriage bolts, flat washers, lock washers, and hex nuts provided by Fabco.
- The screens of the device are fabricated from 1/16" thick perforated aluminum sheet metal with 3/16" (approximately 4.8 mm) round openings.

#### 3.B. Peak Flows/Trash Volumes

Please see the table within Section 3.C. for the hydraulic capacity and recommended max trash storage volume of four common standard size Fabco ScreenBox units. The Fabco ScreenBox is designed to ensure available waterflow area is greater than or equal to the open area of the catch basin outlet pipe opening. This is to ensure that all trash 5 mm or greater in diameter is trapped for the peak design flow. The area of the bypass opening is also designed to be equal to or greater than the area of the catch basin outlet pipe opening. Maximum trash volume is equal to the total open volume inside the ScreenBox, with height up to the bypass opening.

### 3.C. Hydraulic Capacity

Fabco ScreenBox Standard Sizes						
Nominal Clear Space Size	Hydraulic Capacity					Recommended Max Trash Storage Volume (CF)
	Filtered Flow Rate				Bypass Flow Rate (CFS)	
	Empty (CFS)	25% Full (CFS)	50% Full (CFS)	75% Full (CFS)		
18" x 18"	6.4	4.8	3.2	1.6	1.4	0.9
24" x 24"	12.0	9.0	6.0	3.0	2.6	2.4
30" x 30"	17.5	13.1	8.8	4.4	3.8	4.55
36" x 36"	23.1	17.3	11.6	5.8	4.9	7.4

\*Note: Fabco ScreenBox does not have any alternative configurations

The orifice equation below is used to calculate the hydraulic capacity of each ScreenBox Unit:

$$Q = C_d A \sqrt{2gh}$$

where,

$Q$  = flow rate [ $\text{in}^3/\text{s}$ ] \*converted to [CFS and GPM]

$C_d$  = coefficient of discharge [0.62 used by Fabco Industries]

$A$  = area of orifice or net open area [ $\text{in}^2$ ] = area of screen [ $\text{in}^2$ ] \* % open area

$g$  = acceleration from gravity [ $\text{in}/\text{s}^2$ ]

$h$  = head acting on centerline of each screening window [in]

#### **Example Calculation Empty Filtered Flow Rate for a 22" x 22" Fabco ScreenBox:**

$$Q_1 = (0.62) * (274.68[\text{in}^2] * 51\%) * \sqrt{2 * \left(386.4 \left[\frac{\text{in}}{\text{s}^2}\right]\right) * (5.13[\text{in}])}$$

$$Q_1 = 5,469 \left[\frac{\text{in}^3}{\text{s}}\right] \div 1,728$$

$$Q_1 = 3.16 [\text{CFS}]$$

$$Q_2 = (0.62) * (274.68[\text{in}^2] * 51\%) * \sqrt{2 * \left(386.4 \left[\frac{\text{in}}{\text{s}^2}\right]\right) * (12.38[\text{in}])}$$

$$Q_2 = 8,495 \left[\frac{\text{in}^3}{\text{s}}\right] \div 1,728$$

$$Q_2 = 4.92 [\text{CFS}]$$

$$Q_3 = (0.62) * (95.55[\text{in}^2] * 51\%) * \sqrt{2 * \left(386.4 \left[\frac{\text{in}}{\text{s}^2}\right]\right) * (17.00[\text{in}])}$$

$$Q_3 = 3,463 \left[\frac{\text{in}^3}{\text{s}}\right] \div 1,728$$

$$Q_3 = 2.00 [\text{CFS}]$$

$$Q = Q_1 + Q_2 + Q_3 = 10.08 [\text{CFS}]$$

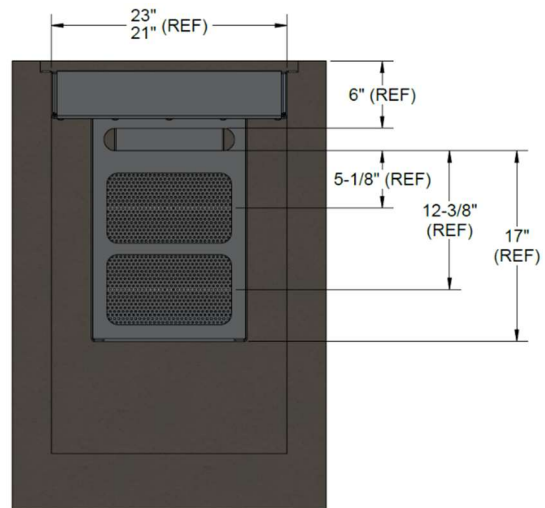

**REFERENCE VIEW**

### **3.D. Comparison Table**

Please see table in Section 3.C. for hydraulic capacity of the four most common sizes of the Fabco ScreenBox.

### **3.E. Design Drawings**

Please refer to Appendix A for a representative design drawing of the Fabco ScreenBox for a Nominal Clear Space of 22" x 22", with mandatory vector control corner fillers.

### **3.F. Alternative Configurations**

The Fabco ScreenBox does not have any alternative configurations.

### **3.G. Internal Bypass**

The bypasses of the Fabco ScreenBox are slot-shaped openings located above the device's screening windows that allow for a flow equal to or greater than that of the outlet pipe opening. The screening windows on the Fabco ScreenBox are engineered to filter at least the trash treatment peak design flow. Thus, the bypass openings of the Fabco ScreenBox are only used when flow into the catch basin exceeds the peak design flow or when peak flows occur after the device has not been maintained to keep blinding to a minimum.

### **3.H. Previously Trapped Trash**

The only scenario in which previously trapped trash can be re-introduced to the downstream stormwater infrastructure is if there is floating trash which rises above and through the bypass opening when a bypass flow scenario occurs as explained in Section 3.G.

### **3.I. Calibration Feature**

The Fabco ScreenBox has a mounting frame with slotted flanges, which allow each flange to adjust within a 1" range. This allows the mounting frame to have a total of 2" adjustability in both the length and width dimensions of the catch basin grate frame. When installing the Fabco ScreenBox, the flanges are to be adjusted to fit flush with the grate frame opening before inserting the device into the catch basin and placing in the corner fillers. To adjust the flanges, a 7/16" socket wrench or equivalent tool can be used to loosen the hex nuts securing each flange. The flanges can then be slid into the necessary position and the hex nuts can be re-tightened to secure the flanges in place.



### 3.J. Photos

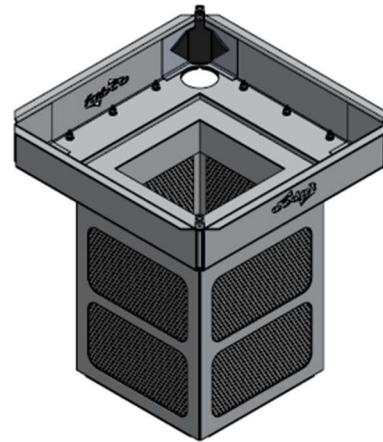
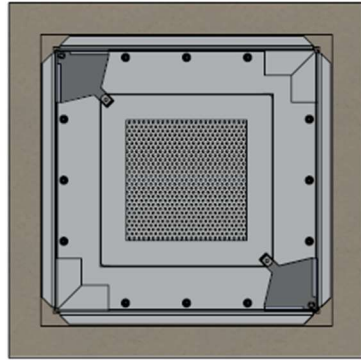

**ISOMETRIC VIEW W/ CORNER FILLER OPEN**

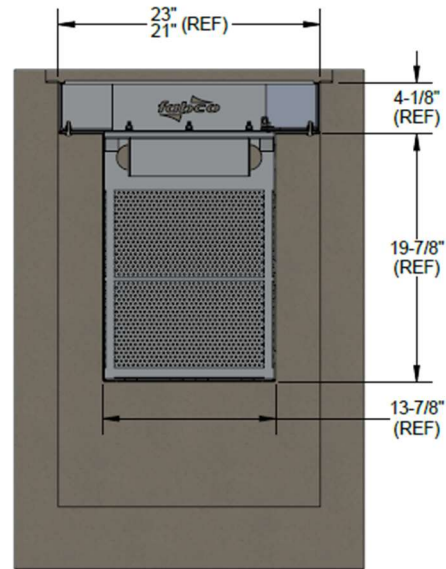
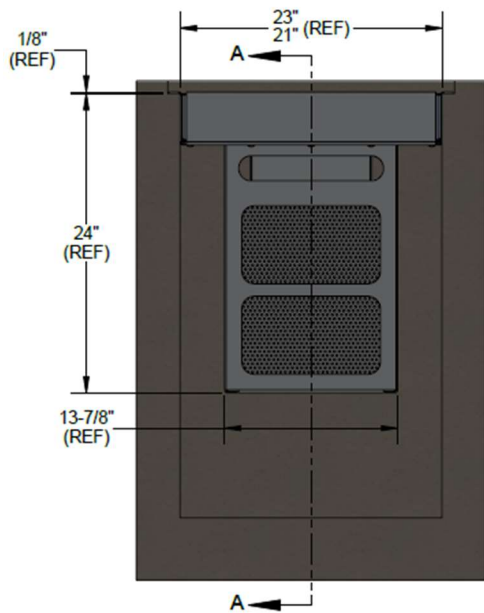

**SECTION A-A**

### 3.K. Material Type

Below is a list of all materials which comprise the Fabco ScreenBox and where the materials are used on the device:

- Screen Material: 1/16" Thick Perforated Aluminum Sheet Metal with  $\varnothing 3/16"$  (approx.  $\varnothing 4.8\text{mm}$ ) Round Holes
- Mounting Frame and Box: 1/8" Thick Aluminum Sheet Metal
- Corner Fillers: 1/16" Thick Aluminum Sheet Metal
- Vector Control Corner Filler Flap: 1/8" Thick Neoprene Rubber
- Vector Control Corner Filler Hooking Point: Zinc-Plated Steel Corner Bracket
- Hardware: 18-8 Stainless Steel Carriage Bolts, Flat Washers, Lock Washers, and Hex Nuts.
- Aluminum tape is also provided to help fill any unwanted gaps after installation.

### **3.L. Design Life**

With expected stormwater conditions and regular maintenance, the Fabco ScreenBox has an expected design life of approximately 10 years.

## **4. Installation Guidance**

---

### **4.A. Standard Device Installation Procedures and Considerations**

The Fabco ScreenBox is designed and manufactured to fit within the specific dimensions of each installation site. Fabco requires that before any purchase, a survey form is filled out reporting measurements of the catch basin(s) on site.

Standard installation of a Fabco ScreenBox follows the procedure steps below:

1. Ensure all site safety requirements are set in place before beginning installation.
2. Follow all proper road safety rules & regulations during installation.
3. Begin by removing the catch basin grate.
4. Carefully place the grate on the ground away from the work area.
5. Measure and record the catch basin frame clear opening length, width, and depth.
6. Using the clear opening measurements recorded in step 5, adjust the flanges on the Fabco ScreenBox to fit flush within the grate frame and rest securely upon the grate support ledges. To adjust the flanges, a 7/16" socket wrench or equivalent tool can be used to loosen the hex nuts securing each flange. The flanges can then be slid into the necessary position and the hex nuts can be re-tightened to secure the flanges in place.
7. Place the adjusted Fabco ScreenBox into the catch basin.
8. Verify each flange is secure and the unit is snug with little movement in the drain.
9. Install corner fillers by using the double-sided tape found on each corner filler.
10. (If necessary) use provided aluminum tape to fill any unwanted gaps that may remain after installation.
11. Reinstall the catch basin grate.

### **4.B. Description of Device Installation Limitations and Non-Standard Device Installation Procedure**

Installation of a Fabco ScreenBox may be limited by the existing protrusions within a catch basin and/or the lack of grate support ledges. If any non-standard installation is required, the installer should please contact their respective sales representative or Fabco sales support at [sales@fabco-industries.com](mailto:sales@fabco-industries.com) or (631) 393-6024. Installation procedure may differ, but design of the Fabco ScreenBox cannot change.

### **4.C. Methods for Diagnosing and Correcting Installation Errors**

Once installed, ensure a proper installation by performing a visual inspection of the entire installed unit. Confirm the device is centered within the catch basin and is sitting securely on the grate support ledges. If the Fabco ScreenBox does not fit securely within the catch basin, clear the opening, remove it, and reinstall it again following the instructions in Section 4.A. If issues persist, contact Fabco sales support to further identify possible solutions. If any critical questions at all arise during or after installation, the install team should please contact their respective sales representative or Fabco sales support (Email: [sales@fabco-industries.com](mailto:sales@fabco-industries.com); Phone: (631) 393-6024) for project specific assistance.

## **5. Operation and Maintenance Information**

---

### **5.A. Inspection Procedures and Frequency Considerations**

Fabco recommends that an installed Fabco ScreenBox is inspected and maintained at a minimum of two times a year on a recurring basis for the life expectancy of the unit. It is recommended that the first inspection and maintenance of the year take place at the start of the local rainy season. The second inspection and maintenance of the year should take place at the end of the local rainy season. If there is no definite rainy season at the install location, Fabco suggests that the two minimum inspections and maintenance should be evenly spaced throughout the year. However, the Municipal Storm Water permit may specify more frequent maintenance intervals.

True necessary inspection and maintenance frequency will depend on the amount of stormwater runoff, pollutant loading, and blinding from trash occurring at the installation site. It is recommended that during the first year after installation a higher frequency of inspections is performed (typically, at least 3-4). This is to ascertain the necessary inspection and maintenance frequency for the install site and determine a baseline expected trash load.

Please note no confined entry is required to inspect the Fabco ScreenBox. Below is the standard inspection procedure:

1. Ensure all site safety requirements are set in place before beginning.
2. Follow all proper road safety rules & regulations during the inspection.
3. Remove the catch basin grate to gain visual access to the Fabco ScreenBox.
4. Visually inspect the device for any damage or unfastening that may have occurred.
5. Keep a record of inspection, noting any irregularity, damage, or loss of secure mounting.
6. Visually inspect the inside of the ScreenBox for heavy sediment, trash, and debris loading. A battery powered flashlight or droplight is recommended for thorough inspection.
7. Measure the trash load using a tape measure or equivalent trash measurement tool.
8. Record trash load measurement.
9. Ensure vector control corner filler view ports are easily opened and accessible.
10. (If necessary) take photos and keep on record.
11. Perform vector control inspection and keep records.
12. Reinstall catch basin grate.

### **5.B. Description of Maintenance Frequency Considerations**

Recurring maintenance is needed to make sure the Fabco ScreenBox can function properly in capturing the trash treatment design flow of the drainage structure in which it's installed. Fabco suggests a minimum maintenance schedule of at least two times a year by removing the trash and debris, sand and silt with a vacuum assisted device. Typically, the maintenance should be scheduled for once at the start of the local rainy season and once at the end of the local rainy season. If there is no defined rainy season, the maintenance can be scheduled equally spaced throughout the year. However, the Municipal Storm Water permit may specify more frequent maintenance intervals. Because the actual trash load on a drain can vary from site to site, the inspection record can be used to properly plan the needed maintenance schedule. To minimize maintenance costs Fabco generally suggests that the clean outs take place any time the device is at 50% full trash capacity.

### **5.C. Maintenance Procedures**

Prior to performing the maintenance procedure, all safety and local traffic control protocols should be put into place. Also ensure local PPE requirements are being met by the maintenance team. Below is the step-by-step maintenance procedure for the Fabco ScreenBox:

1. Remove the catch basin grate and set safely to the side of the drainage access point.
2. Visually inspect inside of the Fabco ScreenBox for heavy sediment, trash, and debris loading. A battery powered flashlight or droplight is recommended for thorough inspection.
3. Remove the sediment, trash, and debris from the system. This can be done manually by hand with shovels and buckets; however, for large scale implementation the most efficient method is to use a vacuum system such as a Vactor truck.
4. Visually inspect the device after cleaning and record any damage or unfastening of the device.
5. If deemed necessary, a power washer can be used to clean the system further.
6. If no critical issues are present or any concerns remain, reinstall the removed catch basin grate.
7. All liquid, oils, sediment, debris, trash and other accumulates removed from the catch basin must be handled and disposed of in accordance with local, state, and federal regulations.

Disposal considerations must be part of a well-planned and scheduled maintenance regime. Solid waste disposal can typically be coordinated with a local landfill, whereas liquid waste can be disposed of at either a wastewater treatment plant, or a municipal vacuum truck decant facility.

### **5.D. Essential Equipment and Materials for Proper Maintenance Activities**

Fabco Industries recommends the following equipment for maintenance of the Fabco ScreenBox:

- Proper safety equipment including but not limited to hardhats, safety vests, gloves, and eye protection.
- Any required traffic control equipment.
- A battery powered flashlight or drop light.
- Shovels and buckets or industrial vacuum.
- Pressure washer (optional).
- Storm grate removal/reinstallation tools.

### **5.E. Description of the Effects of Deferred Maintenance on Device Structural Integrity, Performance, Odors, Etc.**

If maintenance is deferred for the Fabco ScreenBox, the full trash and debris capacity of the Fabco ScreenBox can be reached causing a bypass event when a rainstorm occurs. During a bypass event, debris and trash will flow past the Fabco ScreenBox system and discharge into any downstream stormwater infrastructure or water body. Deferred maintenance will not affect the structural integrity of the Fabco ScreenBox.

### **5.F. Repair Procedures for Device's Structural and Screening Components**

If during inspection or maintenance of the Fabco ScreenBox it's found that the device needs repair, photographs and documentation should be sent to the Fabco assistance team at: [sales@fabco-industries.com](mailto:sales@fabco-industries.com). The Fabco engineering and technical support team can then assess the damage and suggest a repair plan or begin a warranty repair or replacement.

## 6. Vector Control Accessibility

---

### 6.A. Date of Application Submittal to Mosquito Vector Control Association

Application to the Mosquito and Vector Control Association of California (MVCAC) for the Fabco ScreenBox was submitted on August 31, 2022, and a letter of verification was received on September 30, 2022. See Appendix B for the MVCAC verification letter.

### 6.B. Description of Access for Vector Control Personnel

The Fabco ScreenBox features two vector control corner fillers which are self-closing view ports allowing for easy access by Vector Control personnel without requiring any confined space entry or lifting of grates. The view ports are self-closing rubber flaps found on the corners of the Fabco ScreenBox. They can be accessed from above the ScreenBox while a catch basin grate is over the unit. The rubber flaps can be pulled open upward with a tool. When open the 3" diameter view port allows visual and physical access to the bottom of the catch basin for inspection or treatment by Mosquito Vector Control personnel.

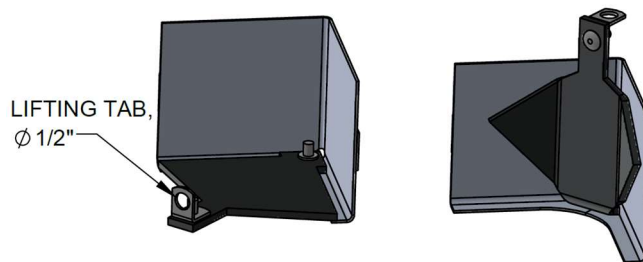

**VECTOR CONTROL CORNER FILLER**  
**(OPEN/CLOSE)**

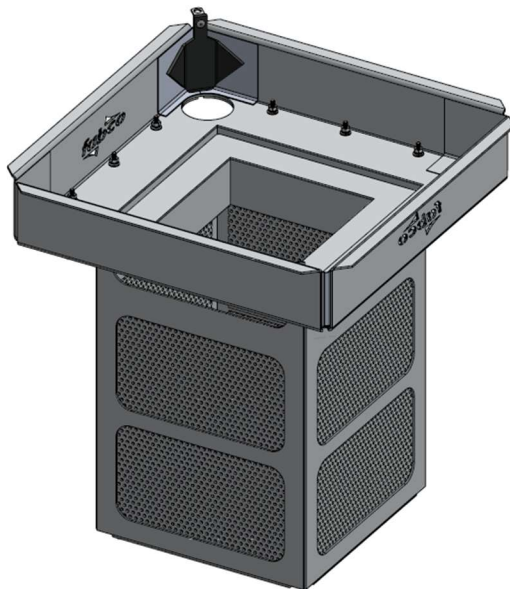

**VECTOR CONTROL CORNER FILLER**  
**OPEN**

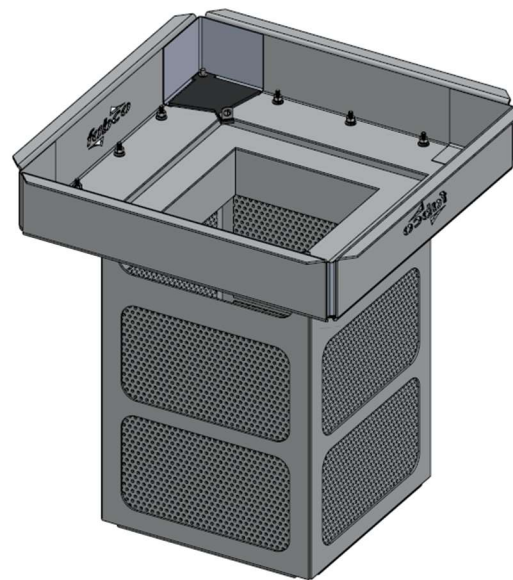

**VECTOR CONTROL CORNER FILLER**  
**CLOSED**

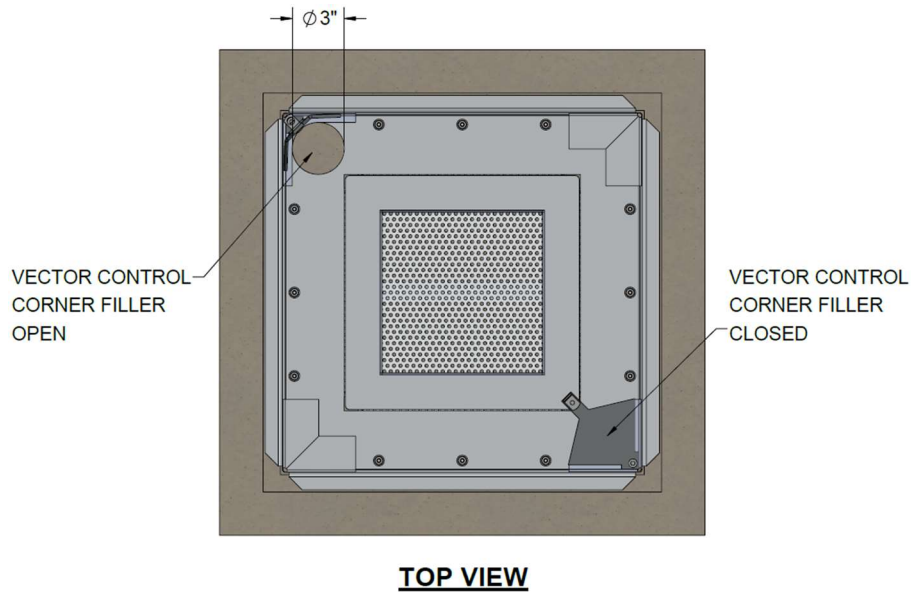

### **6.C. Mosquito Vector Control Association of California Letter of Verification**

Please refer to Appendix B to find the MVCAC letter of verification for the Fabco ScreenBox.

## **7. Reliability Information**

---

### **7.A. Estimated Design Life of Device Components before Major Overhaul**

The life expectancy of the Fabco ScreenBox is estimated by consideration of the materials used to fabricate the Fabco ScreenBox. With expected stormwater conditions and regular maintenance, the Fabco ScreenBox has an estimated design life of 10 years.

### **7.B. Warranty Information**

Fabco Industries, Inc., warrants that the Fabco ScreenBox shall be free from defects in materials and workmanship for a period of 10 years from the date of delivery. The warranty coverage requires that the products must be installed in accordance with all site conditions required by state and local codes, applicable product or industry specifications and guidelines, manufacturer's installation recommendations and other applicable laws. Specifically excluded from the warranty are damages arising from ordinary wear and tear, alteration, or repair by anyone other than Fabco Industries, Inc. or under the direction of Fabco Industries inc. Furthermore, damage due to accident, misuse, abuse or neglect, or any other event not caused by Fabco Industries Inc, is also not covered by the warranty.

If a warranty claim is made and determined to be valid, Fabco Industries, Inc., will either repair or replace the product, solely at the discretion of Fabco Industries, Inc. All warranty claims must be submitted, evaluated, and approved by Fabco Industries, Inc., for the claim to be determined to be valid. There are no other warranties either expressed or implied other than what is specifically specified herein.

### **7.C. Customer Support Information**

Fabco customer support can provide technical information and help with any questions regarding Fabco Industries' products. You can reach our customer support service at:

Fabco Industries, Inc.  
24 Central Drive  
Farmingdale, NY 11735  
Phone: (631) 393-6024  
Email: [sales@fabco-industries.com](mailto:sales@fabco-industries.com)  
Website: [fabco-industries.com](http://fabco-industries.com)

### **8. Field/Lab Testing Information and Analysis**

---

All sizes of the Fabco ScreenBox utilize perforated aluminum sheet metal with  $\varnothing 3/16''$  (approximately  $\varnothing 4.8$  mm) round openings as the screening material. Field/Lab testing is not required for the Fabco ScreenBox. All treated design flow must pass through these screens to enter the outlet pipe, and as such all particles 5mm or larger in diameter within the treatment flow will be physically blocked from passing through. Existing installations of the Fabco ScreenBox, including project sites in California, have yielded only positive results.

# **APPENDIX A**



**NOTES:**

1. WEIGHT (EMPTY): 25 LBS EST.
2. MATERIAL:
  - A) ADJUSTABLE FLANGES AND MAIN FRAME ASSEMBLY: ALUM., 5000 SERIES
  - B) PERF: ALUMINUM, Ø 3/16" HOLES, 51% OPEN
  - C) SUPPORT HARDWARE: CRES 300 SERIES
3. PERFORMANCE CHARACTERISTICS (TYP):
  - A) TOTAL FILTERED FLOW RATE: 4520 GPM (10.1 CFS)
  - B) FLOW RATE THROUGH BYPASS HOOD\*: 990 GPM (2.2 CFS)

\*NOTE THAT THIS IS THE REGULATING FLOW RATE THROUGH THE FILTER.

  - C) BYPASS FLOW RATE: 985 (2.2 CFS)
  - D) DEBRIS CAPACITY: 1.8 CU. FT
4. DESIGNED TO FIT CLEAR OPENING RANGE:
  - A) MINIMUM SIZE: 21" X 21"
  - B) MAXIMUM SIZE: 23" X 23"
5. RECOMMENDED MINIMUM VAULT DEPTH 2-IN BELOW BOTTOM SCREEN
6. TYPICAL INSTALLATION: REMOVE STORM GRATE, MEASURE CATCH BASIN CLEAR OPENING AND ADJUST FLANGES TO REST ON GRATE SUPPORT LEDGE, PLACE SCREEN-BOX IN THE DRAIN OPENING SO THE ADJUSTABLE FLANGES ARE RESTING ON THE GRATE SUPPORT LEDGE, INSTALL CORNER FILL PIECES, REINSTALL STORM GRATE DIRECTLY ON SCREENBOX SUPPORT FLANGES.
7. OIL BOOM REPLACEMENT, P/N KSA2222-1V-720

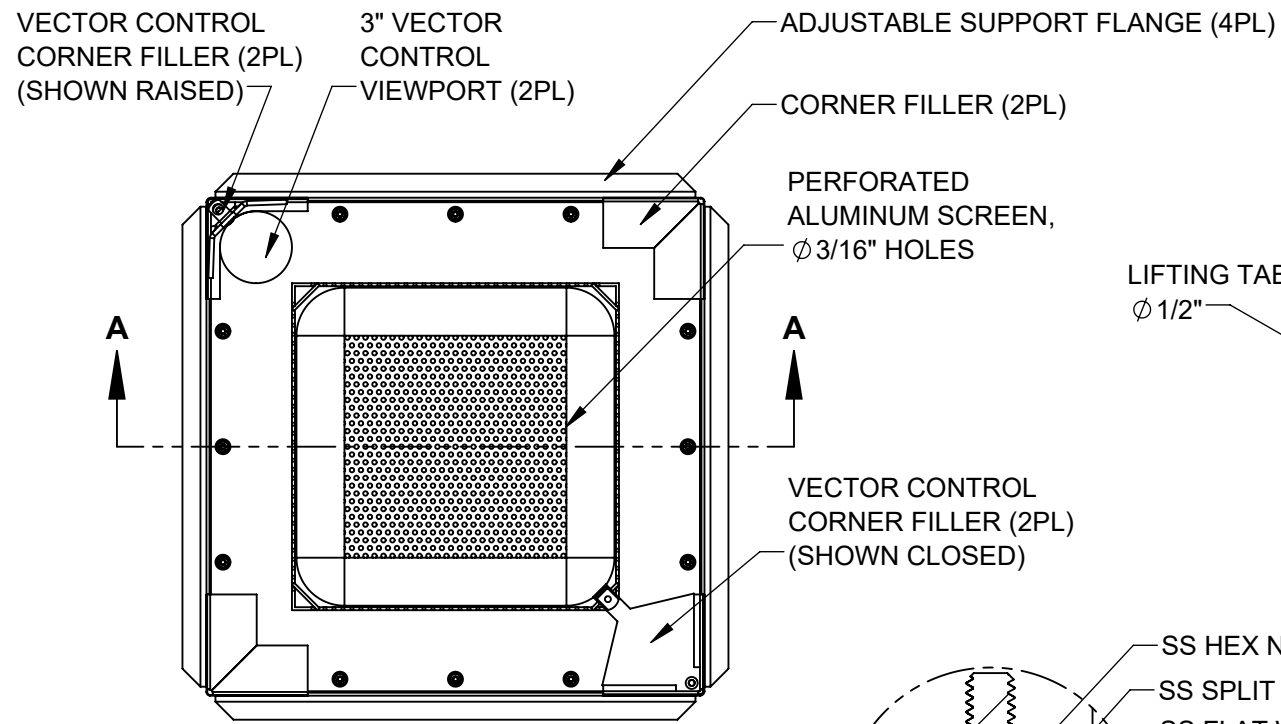

**TOP VIEW  
(PROTECTED BYPASS HOOD HIDDEN)**

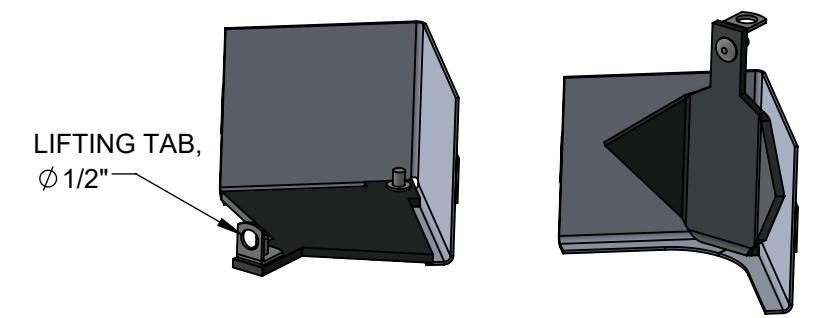

**VECTOR CONTROL CORNER FILLER  
(CLOSED LEFT & OPENED RIGHT)**

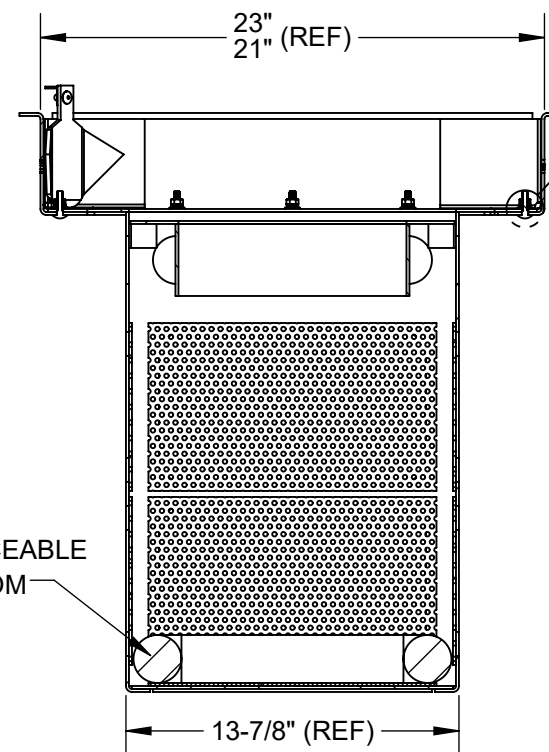
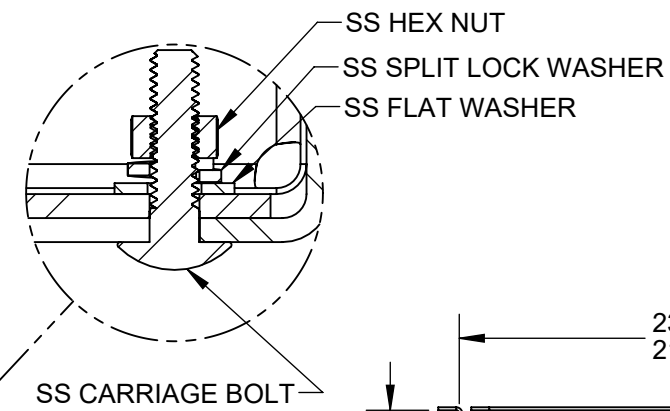

**SECTION A-A**

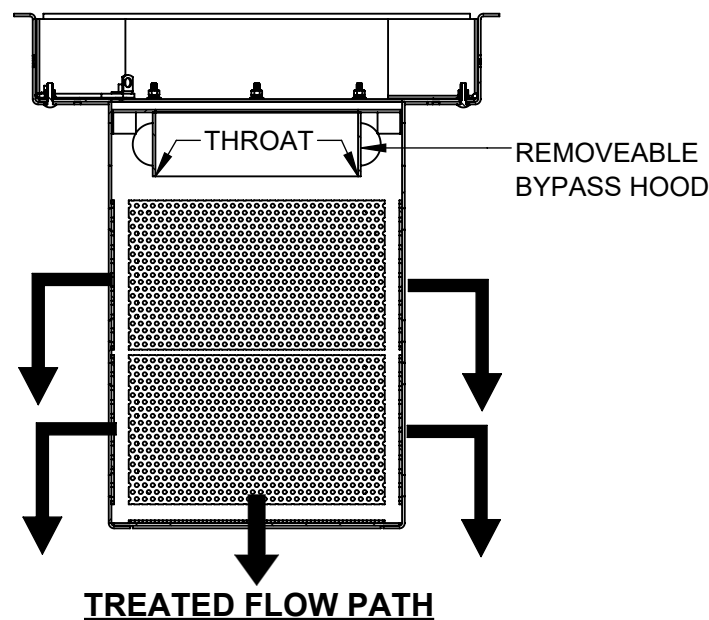
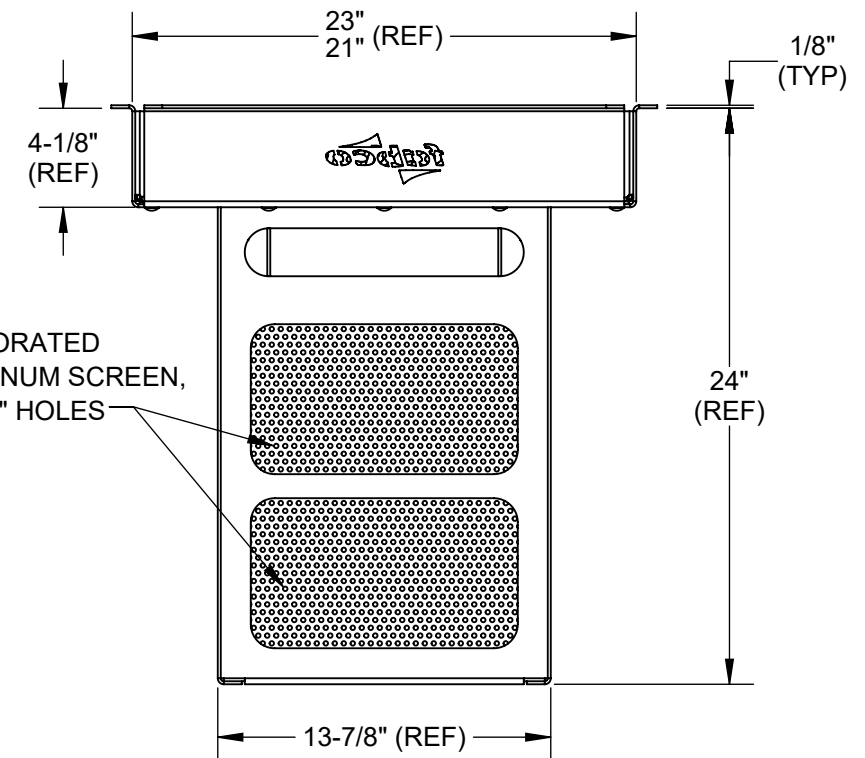

**ENGINEER AND CONTRACTOR NOTE:** FABCO INDUSTRIES WATER QUALITY INSERTS (WQIS) ARE MANUFACTURED TO PROPERLY FIT INLETS BY USING SPECIFIC INFORMATION COMPILED IN A SURVEY OF THE "AS-BUILT" INLET. IN RETROFIT SITUATIONS THE SURVEY IS DONE TO DOCUMENT THE THREE CRITICAL ASPECTS OF WQI DESIGN (GRATE/FRAME MEASUREMENTS, OPEN/CLEAR SPACE MEASUREMENTS, AND PROTRUSION MEASUREMENTS). IN NEW CONSTRUCTION, FABCO PRODUCT DRAWINGS ARE ESSENTIALLY PLACE HOLDERS BASED ON THE SPECIFIED INLETS. ONCE THE INLETS ARE BUILT, THE PROCESS REVERTS TO THE RETROFIT APPROACH OF SURVEYING THE AS-BUILT INLETS TO CONFIRM FABCO INSERT DESIGN. PLEASE USE THE QR CODE TO ACCESS THE SURVEY FORM AND COMPREHENSIVE GUIDANCE OF THE SURVEY PROCESS. ALTERNATIVELY, NAVIGATE TO [www.fabco-industries.com/grate-inlet-survey-guide](http://www.fabco-industries.com/grate-inlet-survey-guide)

**PROPRIETARY AND CONFIDENTIAL**  
THIS DOCUMENT IS THE PROPERTY OF FABCO INDUSTRIES AND IS CONVEYED WITH THE EXPRESS CONDITION THAT IT AND THE INFORMATION CONTAINED IN IT ARE NOT TO BE USED, DISCLOSED, OR REPRODUCED IN WHOLE OR IN PART, FOR ANY PURPOSE WITHOUT THE EXPRESS WRITTEN CONSENT OF FABCO INDUSTRIES. AND THAT NO RIGHT IS GRANTED TO DISCLOSE OR SO USE ANY INFORMATION CONTAINED IN SAID DOCUMENT.

UNLESS OTHERWISE SPECIFIED  
REMOVE ALL BURRS  
BREAK SHARP EDGES .002 - .020  
FILLETS .020 MAX  
DIMENSIONS ARE IN INCHES AND INCLUDE CHEMICALLY APPLIED OR PLATED FINISHES

TOLERANCES:  
DEC .00 ± .01  
DEC .000 ± .005  
FRACT ± 1/16  
ANGLE ± 2°

APPROVAL	DATE
DWN C.G.	7/29/2022
CHKR	
ENGR J.P.	7/29/2022
UPD	

FABCO INDUSTRIES, INC.  
24 CENTRAL DRIVE  
FARMINGDALE, NY 11735  
WWW.FABCO-INDUSTRIES.COM

		<b>SCREENBOX GISB (VECTOR), NOM. C.S. 22" X 22"</b>	
		SIZE DWG. NO. <b>B KSA2222-1V-000</b>	REV <b>C</b>
SCALE: NONE		SHEET 1 OF 1	

PROJECT: SEE NOTES  
MATERIAL: SEE NOTES

# **APPENDIX B**



**MVCAC**  
Mosquito and Vector Control Association of California

One Capitol Mall, Suite 800 • Sacramento, CA 95814 • p: (916) 440-0826 • f: (916) 444-7462 • e: [mvcac@mvcac.org](mailto:mvcac@mvcac.org)

Mr. Hime Athar  
Fabco Industries, Inc  
24 Central Drive  
Farmingdale, NY 11735

September 30, 2022

Dear Mr. Athar,

Thank you for the submission of the Fabco ScreenBox full trash capture device for review by the Mosquito and Vector Control Association of California pursuant to the SWRCB Trash Treatment Control Device Application Requirements. The Association has reviewed the conceptual drawings for the Fabco ScreenBox and verifies that provisions have been included in the design that allow for full visual access to all areas for presence of standing water, and when necessary, allows for treatments of mosquitoes.

While this verification letter confirms that inspection and treatment for the purpose of minimizing mosquito production should be possible with the Fabco ScreenBox as presented, it does not affect the local mosquito control agency's rights and remedies under the State Mosquito Abatement and Vector Control District Law. For example, if the installed device or the associated stormwater system infrastructure becomes a mosquito breeding source, it may be determined by a local mosquito control agency to be a public nuisance in accordance with California Health and Safety Code sections 2060-2067.

"Public nuisance" means any of the following:

1. Any property, excluding water, that has been artificially altered from its natural condition so that it now supports the development, attraction, or harborage of vectors. The presence of vectors in their developmental stages on a property is prima facie evidence that the property is a public nuisance.
2. Any water that is a breeding place for vectors. The presence of vectors in their developmental stages in the water is prima facie evidence that the water is a public nuisance.
3. Any activity that supports the development, attraction, or harborage of vectors, or that facilitates the introduction or spread of vectors. (Heal. & Saf. Code § 2002 (j).)

Declaration of a facility or property as a public nuisance may result in penalties as provided under the Health and Safety Code. Municipalities and the vendors they work with are encouraged to discuss the design, installation, and maintenance of stormwater trash capture devices with their local mosquito control agency to reduce the potential for disease transmission and public nuisance associated with mosquito production.

Sincerely,

Bob Achermann,  
MVCAC Executive Director