



June 1, 2022

Mr. Leo Cosentini
California State Water Resources Control Board
P.O. Box 100
Sacramento, CA 95812-0100

RE: Application for Trash Treatment Control Device, TrashTrap® Net and Fixed Basket End-of-Pipe Systems

Dear Mr. Cosentini,

Enclosed is StormTrap®, LLC's application for the TrashTrap® Net and Fixed Basket End-of-Pipe Stormwater Treatment System for use as a Trash Treatment Control Device. Supporting information for this application is submitted in accordance with the California State Water Resources Control Board document titled, *Trash Treatment Control Device Certification and Fact Sheet Update Requirements*. This application is comprised of the following sections:

- 1) Cover Letter
- 2) Table of Contents
- 3) Physical Description
- 4) Installation Guidance
- 5) Operation and Maintenance Information
- 6) Vector Control Accessibility
- 7) Reliability Information
- 8) Field/Lab Testing Information and Analysis

Thank you for the opportunity to review this application. Please feel free to contact myself if you have any questions or require any additional information upon your review of the materials.

Sincerely,

A handwritten signature in blue ink that reads 'Dan Fajman'.

Dan Fajman
General Manager- Water Quality
StormTrap, LLC

Section 1 – Cover Letter

Section 1.A – Device product name and general description

TrashTrap is a manufactured treatment device, developed by StormTrap, LLC that is designed to remove trash from stormwater using a netting or fixed basket metallic screening mechanism. Stormwater enters the device and must pass through the netting or fixed basket screening mechanism which contains trash 5mm and greater.

Section 1.B – Corporate Info

StormTrap Corporate Officer:

Nathan Olds

Chief Executive Officer

StormTrap, LLC.

815-941-4549 x155

nolds@stormtrap.com

StormTrap authorized representative:

Dan Fajman

General Manager – Water Quality

StormTrap, LLC.

815-941-4549 x245

815-341-9890 (direct)

dfajman@stormtrap.com

Section 1.C – Owner’s Website

The website for StormTrap, LLC. can be located at www.stormtrap.com. The landing page for TrashTrap is www.stormtrap.com/products/trashtrap/.

Section 1.D – Device manufacturing location

StormTrap currently utilizes numerous independent fabrication facilities strategically located throughout the United States. Selection of a fabricator is based upon which facility will provide the most timely and cost-effective delivery to customers at the time an order is placed.

Section 1.E – Brief summary of field/lab results that demonstrate the device functions as described

TrashTrap’s trash removal mechanism utilizes a netting or screening (basket) device. The nominal opening size for the netting or screening material is 4.7mm which allows capture of trash and debris 5mm and greater.

Full scale laboratory testing pertaining specifically to trash has not been performed.

Section 1.F – A brief summary of device limitations

TrashTrap is an engineered system designed to meet site-specific requirements. StormTrap staff will work with the specifying engineer to ensure proper sizing is applied. TrashTrap systems are sized in accordance with the State Water Board's Trash Provisions and the applicable municipal storm water permit. In general, TrashTrap systems must be sized to trap trash 5mm or more for flows generated from the 1 year, 1 hour storm. In addition, TrashTrap systems must be sized to maintain hydraulic capacity prior to required maintenance as specified in the applicable Municipal Storm Water permit.

TrashTrap End-of-Pipe systems are offered in two configurations. The systems can be designed utilizing either a netting or a fixed basket configuration. Examples of the different configurations are within Appendix A. End-of-pipe configurations are installed at the discharge or outlet of the pipe and the TrashTrap system is generally anchored to the concrete spillway. StormTrap staff will work with the specifying engineer to determine the best configuration for the specific project requirements such as water flow, velocity, and geographical physical site constraints.

For TrashTrap End-of-Pipe devices, there are no specific drainage slope limitations provided that the inflow velocity has been evaluated. In any configuration, no driving head is required for the device to function. When utilizing a netting bag to contain floating debris, it is recommended that the water velocity at the net be below 5 ft/sec. If the water velocity exceeds 5 ft/sec, a basket screen is needed in lieu of the netting bag. Contact StormTrap for design options to accommodate larger inflow velocities.

TrashTrap End-of-Pipe systems can be installed either online or offline. Online systems are designed to convey both the trash treatment peak design flow and the peak flows within the device whereas offline systems only convey the trash treatment peak design flow. If an offline system is utilized, additional structures such as a divergence structure upstream of the device may be required. These additional structures must be designed to divert the trash treatment peak design flow to the TrashTrap.

As with all trash containment devices, routine maintenance should be undertaken in order to assure the device functions as designed. TrashTrap units should be inspected and maintained following the recommendations and guidelines in the TrashTrap Inspection and Maintenance Instruction Manual. Within the first year of operation, quarterly inspections are recommended to gauge debris accumulation and to develop a more accurate maintenance schedule. The municipal storm water permit may specify more frequent maintenance intervals.

TrashTrap units can also be installed with remote monitoring technology that measure the current capacity of the trash contained within the system. An advantage of remote monitoring is reduction of physical inspections required. If a remote monitoring device is used, proper maintenance of the device, such as replacement of batteries, etc., needs to be completed to ensure functionality of the remote monitoring technology.

During design, consideration of maintenance activities should be evaluated to ensure that maintenance equipment can easily access the device. Designing with maintenance in mind ensures that the quality of maintenance is maximized, and the cost of maintenance is minimized. TrashTrap systems must be sized to trap trash 5mm or more for flows generated from the 1 year, 1 hour storm. In addition, TrashTrap systems must be sized to maintain



hydraulic capacity prior to required maintenance as specified in the applicable municipal storm water permit.

Section 1.G – Description or list of locations where the device has been installed

Within California, there have been approximately 30 installations in the following areas: Los Angeles (15), Long Beach (5), Oxnard (1), Santa Clara (2), and Signal Hill (7). Contact info for TrashTrap devices installed in Signal Hill, Los Angeles, and Oxnard can be found in **Table 1**, below.

Table 1: TrashTrap Unit Owners

Owner	Owner Address	Project City	Project Address
Signal Hill DPW	2175 Cherry Ave, Signal Hill CA 90755	Signal Hill	20th & Cherry Signal Hill
City of Los Angeles	111 N. Hope St., Los Angeles CA 90012	Los Angeles	W Lomita BLVD & Vermont Ave
Oxnard Public Works	305 W 3rd St., Oxnard CA 93030	Oxnard	S. Victoria Ave. & W Channel Islands BLVD

Section 1.H – Certification Statement

I certify under penalty of law that this document and all attachments were prepared under my direction or supervision in accordance with a system designed to assure that qualified personnel properly gather and evaluate the information submitted. Based on my inquiry of the person or persons that manage the system or those persons directly responsible for gathering the information, to the best of my knowledge and belief, the information submitted is, true, accurate, and complete. I am aware that there are significant penalties for submitting false information, including the possibility of fine and imprisonment for knowing violations.

06/01/2022

Dan Fajman, General Manager- Water Quality

Date

Section 2 – Table of Contents

Section 1 – Cover Letter.....	1
Section 1.A – Device product name and general description.....	1
Section 1.B – Corporate Info.....	1
Section 1.C – Owner’s Website.....	1
Section 1.D – Device manufacturing location.....	1
Section 1.E – Brief summary of field/lab results that demonstrate the device functions as described.....	1
Section 1.F – A brief summary of device limitations	2
Section 1.G – Description or list of locations where the device has been installed.....	3
Section 1.H – Certification Statement	3
Section 2 – Table of Contents	4
Table of Figures.....	6
Table of Tables	6
Section 3 – Physical Description	7
Section 3.A – Trash Capture.....	7
Section 3.B – Peak Flows/Trash Volumes	7
Section 3.C – Hydraulic Capacity.....	8
Section 3.D – Comparison Tables	9
Section 3.E – Design Drawings.....	10
Section 3.F – Alternative Configurations	10
Section 3.G – Internal Bypass	10
Section 3.H – Previously Trapped Trash	10
Section 3.I – Calibration Feature.....	10
Section 3.J – Photos	10
Section 3.K – Material Type	10
Section 3.L – Design Life	11
Section 4 – Installation Guidance	11
Section 4.A – Standard Device Installation Procedures.....	11
Section 4.B – Installation Limitations and/or Non-Standard Installation Procedures	11
Section 4.C – Methods for diagnosing and correcting installation errors.....	11

Section 5 – Operations and Maintenance Information	11
Section 5.A – Inspection procedures and frequency considerations	11
Section 5.B – Description of maintenance frequency related to hydraulic capacity at different levels of trash capture volumes.....	12
Section 5.C – Maintenance Procedures, including procedures to clean the trash capture screen.....	12
Section 5.D – Essential equipment and materials for proper maintenance activities.....	13
Section 5.E – Description of the effects of deferred maintenance on device structural integrity, performance, odors, etc.....	13
Section 5.F – Repair Procedures for the Device’s structural and screening components	13
Section 6 – Vector Control Accessibility	13
Section 6.A – Date Submitted to MCVAC	13
Section 6.B – Vector Control Accessibility Description.....	13
Section 6.C – MVCAC Letter of Verification.....	14
Section 7 – Reliability Information.....	14
Section 7.A – Estimated design life of Device components before major overhaul	14
Section 7.B – Warranty Information.....	14
Section 7.C – Customer support information	14
Section 8 – Field/Lab Testing Information and Analysis.....	14
Section 8.A – 5 mm screening Field/Lab Testing that demonstrates device functionality	14
Section 8.B – Not including a 5 mm screen	14
Appendix A – TrashTrap Design Drawings	15
Appendix B – TrashTrap Material Specifications	19
Appendix C - Installation Manual and Installation Photographs.....	31
Appendix D – TrashTrap Operations and Maintenance Manual	34
Appendix E – TrashTrap Warranty.....	39
Appendix F – MCVAC Verification Letter	42

Table of Figures

Figure 1: TrashTrap End-of-Pipe Rendering.....	7
Figure 2: TrashTrap End-of-Pipe Rendering.....	14

Table of Tables

Table 1: TrashTrap Unit Owners	3
Table 2: Trash Collection Device Configurations	8
Table 3: Trash Collection Capacity vs Hydraulic Capacity (1 Net System).....	9
Table 4: Trash Collection Capacity vs Hydraulic Capacity (2 Net System).....	9
Table 5: Trash Collection Capacity vs Hydraulic Capacity (Fixed Basket System)	9

Section 3 – Physical Description

Section 3.A – Trash Capture

TrashTrap is a manufactured treatment device, that improves the quality of stormwater runoff by containing and removing trash from stormwater. TrashTrap uses netting or a fixed trash basket combined with trash screens to capture debris that is 5 mm or greater in size. The device operates based upon movement of the water and contains no moving parts.

TrashTrap End-of-Pipe systems can be configured utilizing either a netting or a fixed basket configuration. An example of TrashTrap End-of-Pipe configurations can be seen in **Figure 1** below or in [Appendix A](#), pages 15-18.

For all configurations, stormwater enters the device and upon entering the system the stormwater is directed through a netting bag or fixed basket with screen to contain all debris 5 mm or greater in size. When the stormwater exceeds the design flow rate the water level may increase in height above the netting or fixed basket device. When this occurs, the water will then pass through hinged grates above the netting bag or fixed basket device. The hinged grates assure that no debris goes downstream when the flow exceeds the design flow rate. When the storm event subsides, and the water level recedes, trash and debris then enter the netting or basket where the debris is subsequently captured.

For end-of-pipe applications, stormwater is conveyed through an inflow pipe and exits directly to the waterway. All water must pass through the trash containment device (net or fixed basket). TrashTrap models will have 4.7mm netting openings or screen openings.

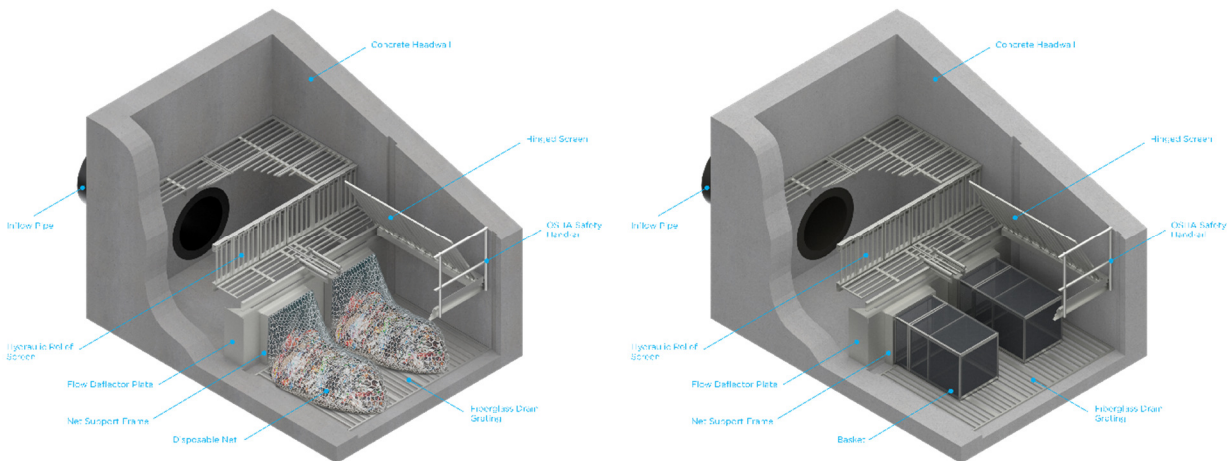

Figure 1: TrashTrap End-of-Pipe Rendering

Section 3.B – Peak Flows/Trash Volumes

The maximum trash capture capacity for the TrashTrap is based upon the calculated volume of the trash capture device (net or screen). The capacities of the various configurations are listed below in **Table 2**.

Table 2: Trash Collection Device Configurations

Trash Device Configurations		Trash Device Width (ft)	Trash Device Height (ft)	Trash Device Length (ft)	Water Quality Flow Rate (cfs) ¹	Recommened Maximum Design Velocity (fps) ²	Trash Capacity (ft ³)
Netting Configurations	30" x 30" Net, 5mm Openings- 8' Length	2.50	2.50	8.00	31.25	5.0	50.0
	30" x 48" Net, 5mm Openings- 8' Length	2.50	4.00	8.00	50.00	5.0	80.0
	30" x 60" Net, 5mm Openings- 8' Length	2.50	5.00	8.00	62.50	5.0	100.0
	36" x 36" Net, 5mm Openings- 8' Length	3.00	3.00	8.00	45.00	5.0	72.0
Metallic Screening	Trash Basket, 5mm Screen- Fixed XL	5.00	2.50	8.00	125.00	10.0	100.0
¹ Water Quality Flow Rate = Trash Device Width x Trash Device Height x Recommended Maximum Design Velocity							
² When using netting configurations it is recommended that the maximum design velocity should not exceed 5 ft/sec							
³ Trash Capacity = Trash Device Width x Height x Length							

Section 3.C – Hydraulic Capacity

Table 3, Table 4, and Table 5, below provides the hydraulic capacity when the device is empty and at several intervals of trash capture volumes up to the device’s maximum trash capture volume. An End-of-Pipe system can have multiple nets or baskets within a single system. To scale **Table 3** for any quantity of nets, simply multiply the values listed in **Table 3** by the quantity of nets within the system. For example, a two net system would double the capacity (**Table 4**), a four net system would quadruple, etc. The same principles would apply to basket configurations. To scale **Table 5** for any quantity of baskets, simply multiply the values listed in **Table 5** by the quantity of baskets within the system.

Hydraulic flow capacity for all configurations is calculated using the following formula:

$$\text{Flow} = \text{Device Length} - (\text{Device Length} \times \text{Percent Blockage}) \times \text{Cross Sectional Open Area} \times \text{Design Velocity.}$$

Example calc: 30" x 30" net, 85% blockage Flow = [8' – (8' x 0.85)] x 3.94ft² x 5ft/sec = 23.63 cfs

The device length is dependent on the configuration selected. For example, a net or basket can have variable lengths based on site conditions (i.e., 6' length or 8' length). The cross-sectional open area is the surface area within a net or basket. The cross-section open area varies depending on the netting or basket dimensions listed in **Table 2**. It should also be noted that within the cross-sectional area calculation for a net, expansion of netting was not accounted for within the calculation to provide a more conservative calculation. The design velocity varies depending on if a net or basket is utilized. For example, as stated in **Table 2**, a netting design velocity is 5 ft/sec and a basket is 10 ft/sec.

Table 3: Trash Collection Capacity vs Hydraulic Capacity (1 Net System)

STNTT-1 (Max Design Velocity is 5 ft/s)								
	30" x 30" Net, 5mm Openings - 8ft		30" x 48" Net, 5mm Openings - 8ft		30" x 60" Net, 5mm Openings - 8ft		36" x 36" Net, 5mm Openings - 8ft	
Percent Blockage (Net)	Net Flow (cfs)	Internal Bypass (cfs)	Net Flow (cfs)	Internal Bypass (cfs)	Net Flow (cfs)	Internal Bypass (cfs)	Net Flow (cfs)	Internal Bypass (cfs)
10%	31.25	0.00	50.00	0.00	62.50	0.00	45.00	0.00
20%	31.25	0.00	50.00	0.00	62.50	0.00	45.00	0.00
30%	31.25	0.00	50.00	0.00	62.50	0.00	45.00	0.00
40%	31.25	0.00	50.00	0.00	62.50	0.00	45.00	0.00
50%	31.25	0.00	50.00	0.00	62.50	0.00	45.00	0.00
60%	31.25	0.00	50.00	0.00	62.50	0.00	45.00	0.00
70%	31.25	0.00	50.00	0.00	62.50	0.00	45.00	0.00
80%	31.25	0.00	39.86	10.14	44.56	17.94	37.81	7.19
85.0%	23.63	7.62	29.89	20.11	33.42	29.08	28.36	16.64
90.0%	15.76	15.49	19.93	30.07	22.28	40.22	18.91	26.09
95.0%	7.88	23.37	9.96	40.04	11.14	51.36	9.45	35.55
100.0%	0.00	31.25	0.00	50.00	0.00	62.50	0.00	45.00

Table 4: Trash Collection Capacity vs Hydraulic Capacity (2 Net System)

STNTT-2 (Max Design Velocity is 5 ft/s)								
	30" x 30" Net, 5mm Openings - 8ft		30" x 48" Net, 5mm Openings - 8ft		30" x 60" Net, 5mm Openings - 8ft		36" x 36" Net, 5mm Openings - 8ft	
Percent Blockage (Net)	Net Flow (cfs)	Internal Bypass (cfs)	Net Flow (cfs)	Internal Bypass (cfs)	Net Flow (cfs)	Internal Bypass (cfs)	Net Flow (cfs)	Internal Bypass (cfs)
10%	62.50	0.00	100.00	0.00	125.00	0.00	90.00	0.00
20%	62.50	0.00	100.00	0.00	125.00	0.00	90.00	0.00
30%	62.50	0.00	100.00	0.00	125.00	0.00	90.00	0.00
40%	62.50	0.00	100.00	0.00	125.00	0.00	90.00	0.00
50%	62.50	0.00	100.00	0.00	125.00	0.00	90.00	0.00
60%	62.50	0.00	100.00	0.00	125.00	0.00	90.00	0.00
70%	62.50	0.00	100.00	0.00	125.00	0.00	90.00	0.00
80%	62.50	0.00	79.72	20.28	89.12	35.88	75.62	14.38
85.0%	47.27	15.23	59.79	40.21	66.84	58.16	56.72	33.28
90.0%	31.51	30.99	39.86	60.14	44.56	80.44	37.81	52.19
95.0%	15.76	46.74	19.93	80.07	22.28	102.72	18.91	71.09
100.0%	0.00	62.50	0.00	100.00	0.00	125.00	0.00	90.00

Table 5: Trash Collection Capacity vs Hydraulic Capacity (Fixed Basket System)

TrashTrap Hydraulic Capacity		
	Trash Basket, <5mm Openings - Fixed XL	
Percent Blockage (Net)	Net Flow (cfs)	Internal Bypass (cfs)
10%	125.00	0.00
20%	125.00	0.00
30%	125.00	0.00
40%	125.00	0.00
50%	125.00	0.00
60%	125.00	0.00
70%	125.00	0.00
80%	122.45	2.55
85%	91.84	33.16
90%	61.22	63.78
95%	30.61	94.39
100%	0.00	125.00

Section 3.D – Comparison Tables

Table 3, Table 4, and Table 5, above, contain the peak flow rates and recommended maximum trash capture volumes per net or basket. TrashTrap units can have multiple nets or baskets dependent upon project criteria.

Section 3.E – Design Drawings

Standard drawings can be found in [Appendix A](#), pages 15-18.

Section 3.F – Alternative Configurations

TrashTrap is not offered in any alternative configurations that would alter the trash capture capabilities or installation requirements. Configuration selection is dependent upon the anticipated velocities to be encountered as well as maintenance preferences of the owner or end user. For example, if the velocities are anticipated to be less than 5 ft/sec, a net or basket configuration would be acceptable. If the velocity exceeds 5 ft/sec, a basket is required.

Section 3.G – Internal Bypass

TrashTrap systems are designed with an internal bypass for trash. The trash bypass is comprised of a hydraulic relief screen above the netting or basket. The hydraulic relief screen is hinged and inclined in the direction of flow. If the trash containment device is completely full or the flows are in excess of the designed capacity, the hydraulic screen will open, and the flow is then bypassed.

Section 3.H – Previously Trapped Trash

The trash capture devices (net or screen basket configurations) within the TrashTrap use openings that are 4.7 mm to eliminate debris from escaping the device. Although unlikely, if the openings in a net break, previously captured trash could be re-introduced into the effluent stream. To mitigate the potential for an opening to break, the design velocities of the influent must be evaluated and planning routine maintenance is also needed to ensure the trash capacity is not exceeded. When evaluating configurations, ensure the influent velocity does not exceed the recommended design velocities listed in **Table 2**. If the velocities exceed the recommended values, it is suggested to place the system in an offline configuration. Another consideration to reduce the potential for a net opening to break is to ensure the trash capacity is not exceeded. Excess trash within a netting bag may increase the potential for a netting bag to tear when being removed during maintenance.

Section 3.I – Calibration Feature

TrashTrap does not include or require an adjustable calibration feature.

Section 3.J – Photos

[Appendix C](#), pages 31-33, contain TrashTrap installation photographs.

Section 3.K – Material Type

TrashTrap systems are housed within precast reinforced concrete structures. The internal metal components are comprised of either marine-grade galvanized aluminum or stainless steel, if brackish water is anticipated. Netting material is a knotless knitted nylon net which is secured to a wooden or plastic frame. [Appendix B](#), pages 19-30, contains example TrashTrap specifications.

Section 3.L – Design Life

TrashTrap systems are designed and manufactured for a life expectancy in excess of 50+ years.

Section 4 – Installation Guidance

Section 4.A – Standard Device Installation Procedures

[Appendix C](#), pages 31-33, contains procedures and considerations for installing TrashTrap devices.

Section 4.B – Installation Limitations and/or Non-Standard Installation Procedures

Installation procedure may differ, but the design can not change. The units are standardized and there are no non-standard installation procedures. Contact StormTrap for site specific recommendations and techniques.

Section 4.C – Methods for diagnosing and correcting installation errors

StormTrap has a representative meet with the installing contractor prior to delivery for a pre-construction meeting and a StormTrap representative will be on site during the installation to ensure units are delivered and installed correctly. If an error occurs, the StormTrap representative will work with the installing contractor to ensure the unit is installed correctly.

Section 5 – Operations and Maintenance Information

Section 5.A – Inspection procedures and frequency considerations

[Appendix D](#), pages 34-38, contains inspection procedures and inspection frequency considerations for TrashTrap devices.

Regular inspections are recommended to ensure that the system is functioning as designed. Please contact your StormTrap representative if you have any questions regarding the inspection and maintenance of the TrashTrap system.

TrashTrap End-of-Pipe systems do not require entry into the system for maintenance.

TrashTrap systems are recommended for inspection whenever upstream and downstream catch basins and stormwater pipes of the stormwater collection system are inspected or maintained. This will economize the cost of the inspection if it is done at the same time.

Within the first year of operation, quarterly inspections are recommended to gauge debris accumulation and to develop a more accurate maintenance schedule. If inspected on an annual basis, the inspection should be conducted before the stormwater season begins to ensure that the system is functioning properly for the upcoming storm season.

Inspections should be done such that a sufficient time has lapsed since the most recent rain event to allow for a static water condition. Visually inspect the system. For debris accumulation, visually inspect the netting or screening basket to determine the capacity and inspect the inlet pipe opening to ensure that the silt level or any foreign objects are not blocking the pipe.

TrashTrap units can also be installed with remote monitoring technology that measures the current capacity of the trash contained within the system to decrease the amount of physical inspections required. If a remote monitoring device is used, proper maintenance of the device, such as replacement of batteries, etc., needs to be completed to ensure functionality of the remote monitoring technology.

Section 5.B – Description of maintenance frequency related to hydraulic capacity at different levels of trash capture volumes

As shown in **Tables 3, 4, and 5**, hydraulic capacity is not affected until the device reaches 70%-90% of the trash capture volume, depending on the configuration utilized. When the trash volume exceeds the specified capacity, bypass may occur due to occlusion of the netting or basket. It is recommended that maintenance occurs prior to reaching 70%-90% of the trash volume to ensure bypass does not occur. However, the municipal storm water permit may specify more frequent maintenance.

Section 5.C – Maintenance Procedures, including procedures to clean the trash capture screen

[Appendix D](#), pages 34-38, contains maintenance procedures and a description of necessary equipment and materials to maintain TrashTrap devices.

Maintenance should be done such that a sufficient time has lapsed since the most recent rain event to allow for a static water condition for the duration of the maintenance process.

For floatable debris removal when a netting bag is utilized, remove the netting bag by lifting the bag by the netting frame and move it upwards along the netting support frame. Once the netting component is fully removed from the system, it should be properly disposed of per local, state, and federal guidelines and regulations. Typically, the netting component can be disposed of in a common dumpster receptacle.

For floatable debris removal when a fixed basket is utilized, a vacuum truck, or similar trailer mounted equipment can be used to remove the debris. Lift the top section of the screening basket to access the inside of the basket. Take the vacuum hose and remove all debris from inside of the basket. Sewer jetting equipment or a spray lance can be used to force debris to the vacuum hose.

Finally, for netting configurations, install a new net assembly into place by sliding the netting frame down the support frame and ensure the netting lays in a way that the netting is not restricted. For fixed basket configurations ensure that the top of the basket is closed and secured.

Secure any access openings and properly dispose of trash per local, state, and federal guidelines. Proof of inspections and maintenance is the responsibility of the owner. All inspection reports and data should be kept on site or at a location where they will be accessible for years in the future. Some municipalities require these inspection and cleaning reports to be forwarded to the proper governmental permitting agency on an annual basis. Refer to your local and national regulations for any additional maintenance requirements and schedules not contained herein. Inspections and maintenance should be a part of the standard operating procedure.

Section 5.D – Essential equipment and materials for proper maintenance activities

Maintenance should be done utilizing proper personal protective equipment such as: safety glasses, hard-hat, gloves, first aid kit, traffic cones, etc. In addition to PPE materials, if a netting configuration is utilized, it is recommended to use lifting equipment (gaff hooks, crane, hoist, or boom truck) that is rated and capable of lifting the netting material filled with trash and debris completely from the system and into a trash receptacle. If a basket configuration is utilized, a vacuum truck or similar type equipment is recommended to remove trash and debris.

Section 5.E – Description of the effects of deferred maintenance on device structural integrity, performance, odors, etc.

Maintenance frequency considerations are highly dependent on site-specific loading conditions and rainfall frequency. Quarterly inspections within the first year of installation will assist with establishing an accurate maintenance cycle to ensure the device maintenance is not unintentionally deferred. If maintenance is delayed to the point where the debris in the system exceeds the trash capacity of the device, performance may become affected, and maintenance will become more difficult.

Section 5.F – Repair Procedures for the Device’s structural and screening components

If any TrashTrap components need to be repaired and/or modified in any way, contact StormTrap for assistance.

Section 6 – Vector Control Accessibility

Section 6.A – Date Submitted to MCVAC

The application was submitted for vector control accessibility design verification via email to the Mosquito Vector Control Association of California (MVAC) Trashtreatment@mvacac.org on April 28, 2022 and a MCVAC verification letter was issued on May 31, 2022.

Section 6.B – Vector Control Accessibility Description

TrashTrap systems are intended to drain dry between storm events. TrashTrap systems do not need permanent pools of water to function. In the event that a design engineer elects to incorporate a sump that may contain standing water within the system, accessibility to the device does not change. **Figure 2** has been inserted into this section for ease of visualization.

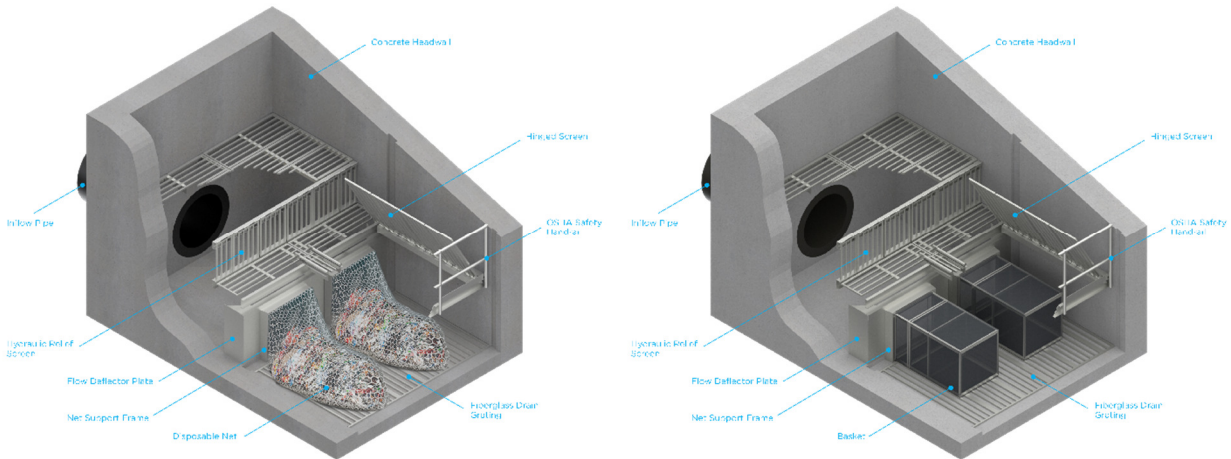

Figure 2: TrashTrap End-of-Pipe Rendering

For End-of-Pipe configurations, the systems are installed above grade. During vector control inspection, no components within the device need to be moved in any configuration.

Section 6.C – MVCAC Letter of Verification

Appendix F, page 42 – MVCAC Letter of Verification can be found in Appendix F.

Section 7 – Reliability Information

Section 7.A – Estimated design life of Device components before major overhaul

TrashTrap systems are designed and manufactured for a life expectancy in excess of 50+ years.

Section 7.B – Warranty Information

Appendix E, pages 39-41, contains the TrashTrap warranty information. StormTrap provides a five-year limited warranty on TrashTrap devices.

Section 7.C – Customer support information

Local StormTrap representatives are available to provide customer support. A list of StormTrap representatives and the regions that they support can be found at:

<http://stormtrap.com/contact-list/>.

Section 8 – Field/Lab Testing Information and Analysis

Section 8.A – 5 mm screening Field/Lab Testing that demonstrates device functionality

TrashTrap currently does not have field or lab testing information and analysis specifically related to trash capture.

Section 8.B – Not including a 5 mm screen

Not Applicable to a TrashTrap unit.

Appendix A – TrashTrap Design Drawings

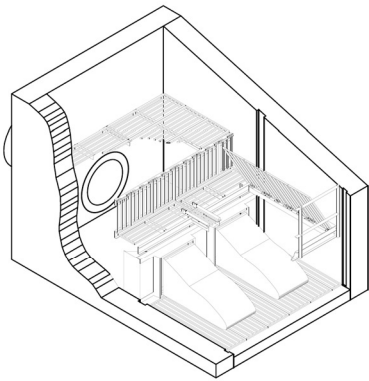

END-OF-PIPE TRASHTRAP

SHEET INDEX

PAGE	DESCRIPTION
0.0	COVER SHEET
1.0	END-OF-PIPE TRASHTRAP NETTING SYSTEM
2.0	END-OF-PIPE TRASHTRAP NETTING SYSTEM DETAILS

STORMTRAP CONTACT INFORMATION

TRASHTRAP SUPPLIER: STORMTRAP
 CONTACT NAME:
 CELL PHONE:
 SALES EMAIL:

StormTrap®
INVENTED LISTED AT: (414) 211-5100/STORMTRAP.COM/PATENT

1287 WINDHAM PARKWAY
 ROMEVILLE, IL 60446
 P: 815-941-4549 / F: 331-318-5347

ENGINEER INFORMATION:

PROJECT INFORMATION:

CURRENT ISSUE DATE:

ISSUED FOR:

PRELIMINARY

REVISIONS:

REV.	DATE	ISSUED FOR:	OWN BY:

SCALE:

NTS

SHEET TITLE:

COVER SHEET

SHEET NUMBER:

0.0

End-of-Pipe Netting Configuration

SYSTEM INFORMATION

WATER QUALITY FLOW RATE: CFS
 PEAK FLOW RATE: CFS
 DEBRIS STORAGE: 100 FT³
 INLET INVERT:

BILL OF MATERIALS - END OF PIPE

ITEM	QTY	DESCRIPTION	NOTE
1	1	NET SUPPORT FRAME ASSEMBLY	--
2	2	MESH NET	--
3	2	PLATFORM SUPPORT (UPSTREAM)	--
4	1	PLATFORM SUPPORT (END)	--
5	3	GRATING SUPPORT	--
6	4	HINGED PROCESS SCREEN	--
7	6	NET ACCESS GRATING PANEL	--
8	2	PLATFORM GRATING PANEL	--
9	1	FIBERGLASS DRAIN GRATING PANEL	--
10	1	VERTICAL BAR ASSEMBLY (END)	--
11	1	NET ACCESS LOCK BAR	--
12	--	FASTENING HARDWARE KIT	--

NOTES & SPECIFICATIONS:

- NET BAGS: 90" LG. WITH 30" X 30" INLET OPENING (NOMINAL DIMENSIONS).
- MAX DESIGN FLOW RATE (NETS) = 62.50 CFS. ADDITIONAL FLOW SHALL PASS THROUGH THE PROCESS SCREENING.
- UNLESS OTHERWISE SPECIFIED: NET GUIDE ASSEMBLY, LIFT FRAME AND ALL ASSOCIATED PCT SYSTEM COMPONENTS SHALL BE TYPE 316 STAINLESS STEEL. ALL FASTENING HARDWARE SHALL BE TYPE 316 STAINLESS STEEL.
- UNLESS OTHERWISE SPECIFIED: THE NETTING FACILITY SHALL BE CONSTRUCTED SUCH THAT ALL PROCESS BAR GRATING, GRATING, HINGED JOINTS AND CONNECTION POINTS OF FRAME WORK SHALL NOT EXCEED 1/4 INCHES. NO OPENINGS SHALL BE ALLOWED WHICH PROVIDE A MEANS OF BYPASSING OR SHORT CIRCUITING MATERIAL 1/4 INCH OR GREATER.
- BAR SCREEN (PROCESS TYPE): 1" x 3/16" BB, 11/16" O.C., 1/2" CLEAR SPACING, TYPE 316 STAINLESS STEEL.
- FIXED DRAIN GRATING (BELOW NETS): STRONGWELL "SAFEDECK" OR EQUAL.
- GENERAL CONTRACTOR TO VERIFY DIMENSIONS AND ELEVATIONS SHOWN.

StormTrap®
INVENTED LISTED AT: (414) 211-5100/STORMTRAP.COM/PATENT

1287 WINDHAM PARKWAY
 ROMEVILLE, IL 60446
 P: 815-941-4549 / F: 331-318-5347

ENGINEER INFORMATION:

PROJECT INFORMATION:

CURRENT ISSUE DATE:

ISSUED FOR:

PRELIMINARY

REVISIONS:

REV.	DATE	ISSUED FOR:	OWN BY:

SCALE:

NTS

SHEET TITLE:

30 x 30 - 2 NET
 END-OF-PIPE
 TRASHTRAP
 NETTING SYSTEM

SHEET NUMBER:

1.0

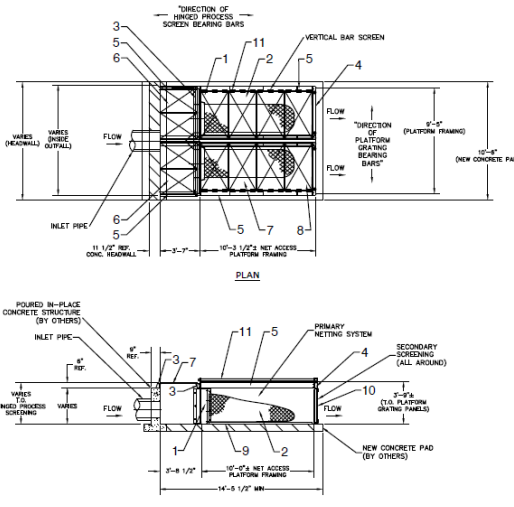

PLAN

SIDE ELEVATION SECTION

End-of-Pipe Netting Configuration

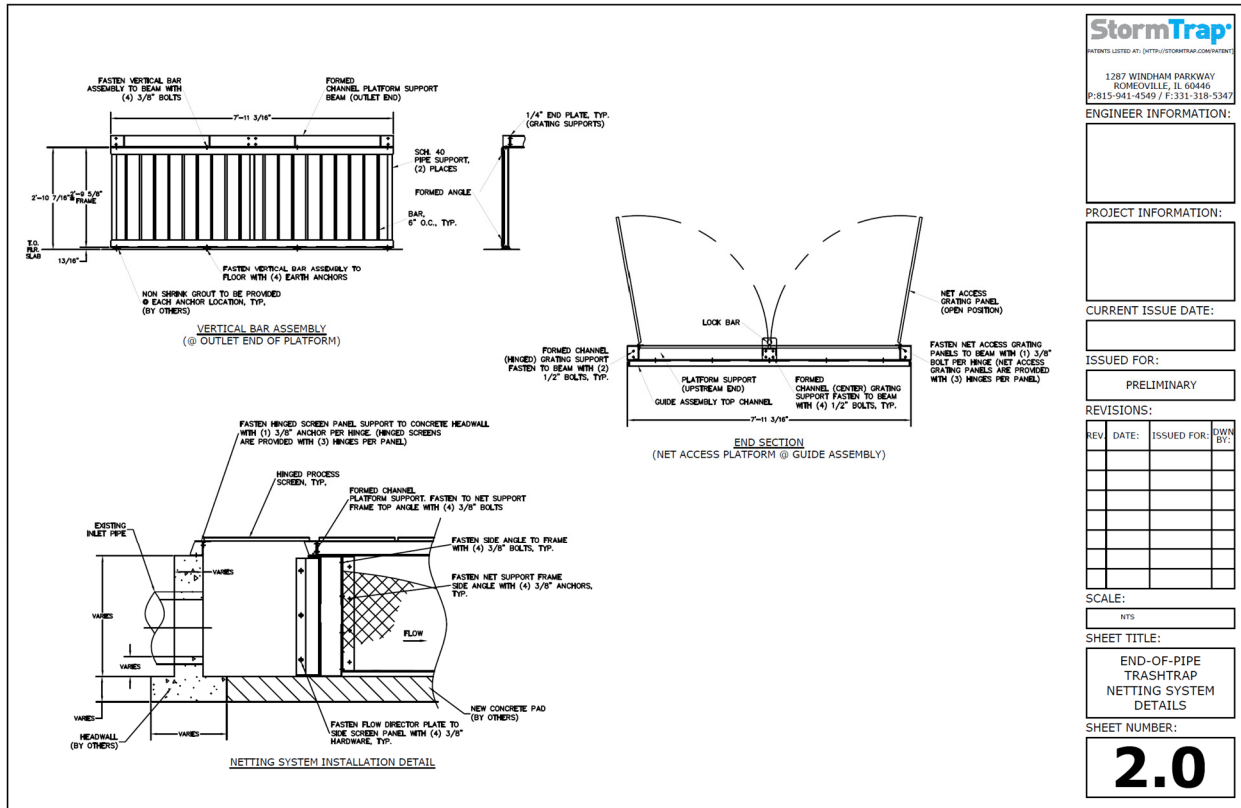

End-of-Pipe Netting Configuration



SHEET INDEX	
PAGE	DESCRIPTION
0.0	COVER SHEET
1.0	END-OF-PIPE TRASHTRAP FIXED BASKET SYSTEM
2.0	END-OF-PIPE TRASHTRAP BASKET SYSTEM DETAILS

StormTrap®
PATENTS LISTED AT: [HTTP://STORMTRAP.COM/PATENTS](http://stormtrap.com/patents)

1287 WINDHAM PARKWAY
 ROMEOVILLE, IL 60446
 P: 815-941-4549 / F: 331-318-5347

ENGINEER INFORMATION:

PROJECT INFORMATION:

CURRENT ISSUE DATE:

ISSUED FOR:

PRELIMINARY

REVISIONS:

REV.	DATE	ISSUED FOR:	OWN BY:

SCALE:

NTS

SHEET TITLE:

COVER SHEET

SHEET NUMBER:

0.0

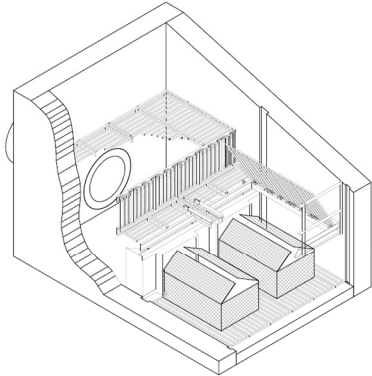

END-OF-PIPE TRASHTRAP

End-of-Pipe Basket Configuration

SYSTEM INFORMATION

WATER QUALITY FLOW RATE: CFS

PEAK FLOW RATE: CFS

DEBRIS STORAGE: 100 FT³

INLET INVERT:

BILL OF MATERIALS - END OF PIPE

ITEM	QTY	DESCRIPTION	NOTE
1	1	FRAME ASSEMBLY	--
2	2	FIXED BASKET	--
3	2	PLATFORM SUPPORT (UPSTREAM)	--
4	1	PLATFORM SUPPORT (END)	--
5	3	GRATING SUPPORT	--
6	4	HINGED PROCESS SCREEN	--
7	6	ACCESS GRATING PANEL	--
8	2	PLATFORM GRATING PANEL	--
9	AS REQ.	FIBERGLASS DRAIN GRATING PANEL	--
10	1	VERTICAL BAR ASSEMBLY (END)	--
11	1	ACCESS LOCK BAR	--
12	--	FASTENING HARDWARE KIT	--

NOTES & SPECIFICATIONS:

- NET BAGS: 96" LG. WITH 30" x 60" INLET OPENING (NOMINAL DIMENSIONS).
- MAX DESIGN FLOW RATE [BASKET] = 125 CFS. ADDITIONAL FLOW SHALL PASS THROUGH THE PROCESS SCREENING.
- UNLESS OTHERWISE SPECIFIED: FRAME ASSEMBLY, FIXED BASKET AND ALL ASSOCIATED PCT SYSTEM COMPONENTS SHALL BE TYPE 316 STAINLESS STEEL. ALL FASTENING HARDWARE SHALL BE TYPE 316 STAINLESS STEEL.
- UNLESS OTHERWISE SPECIFIED: THE BASKET FACILITY SHALL BE CONSTRUCTED SUCH THAT ALL PROCESS BAR SPACINGS, GRATING, HINGED JOINTS AND CONNECTION POINTS OF FRAME WORK SHALL NOT EXCEED 1/4 INCHES. NO OPENINGS SHALL BE ALLOWED WHICH PROVIDE A MEANS OF BYPASSING OR SHORT CIRCUITING MATERIAL 1/4 INCH OR GREATER.
- BAR SCREEN (PROCESS TYPE): 1" x 3/16" BB, 11/16" O.C., 1/2" CLEAR SPACING, TYPE 316 STAINLESS STEEL.
- FIXED DRAIN GRATING (BELOW NETS): STROMWELL "SAFEDECK" OR EQUAL.
- GENERAL CONTRACTOR TO VERIFY DIMENSIONS AND ELEVATIONS SHOWN.

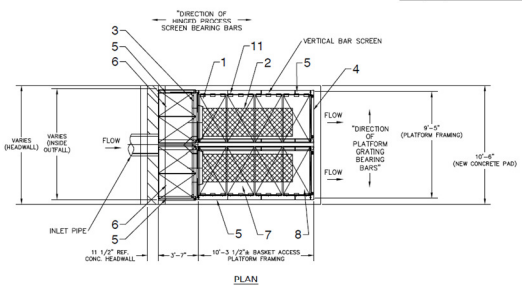

PLAN

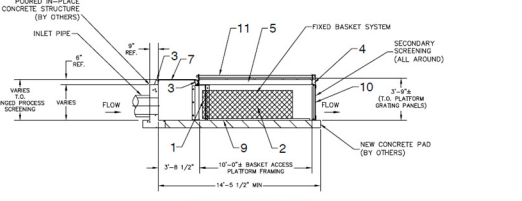

SIDE ELEVATION SECTION

StormTrap®
PATENTS LISTED AT: [HTTP://STORMTRAP.COM/PATENTS](http://stormtrap.com/patents)

1287 WINDHAM PARKWAY
 ROMEOVILLE, IL 60446
 P: 815-941-4549 / F: 331-318-5347

ENGINEER INFORMATION:

PROJECT INFORMATION:

CURRENT ISSUE DATE:

ISSUED FOR:

PRELIMINARY

REVISIONS:

REV.	DATE	ISSUED FOR:	OWN BY:

SCALE:

NTS

SHEET TITLE:

END-OF-PIPE TRASHTRAP BASKET SYSTEM

SHEET NUMBER:

1.0

End-of-Pipe Basket Configuration

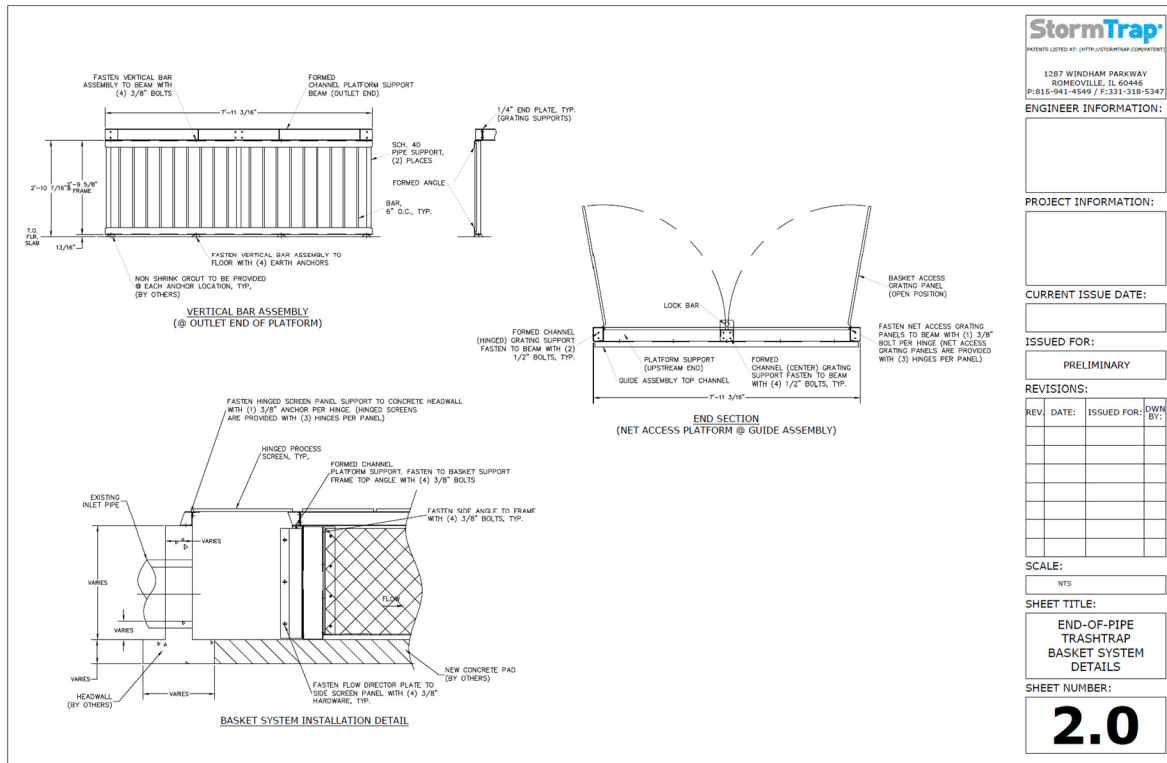

End-of-Pipe Basket Configuration

Please note, the drawings provided in this section are for reference only. They are for example only. End of Pipe TrashTrap drawings are custom drafted and designed based on site specific criteria.

Appendix B – TrashTrap Material Specifications

The section must be carefully reviewed and edited by the Engineer to meet the requirements of the project and local building code. Coordinate this section with other specification sections and the Drawings.

Verify latest version of specifications

PART 1-GENERAL

1.1 DESCRIPTION

- A. This work shall consist of installing a TrashTrap®, generally referred to as a Manufactured Treatment Device (MTD), for the purification of stormwater run-off at each location as shown on the contract plans. The unit shall treat the water quality design storm flow and drain excess flows as specified on the contract drawings.
- B. The MTD shall include at least one or more treatment systems for floatable suspended solids capture with net(s) or screening basket(s). During water quality flow events, the MTD shall retain matter that exceeds the opening size of the trash treatment device (netting bags or screening baskets) such as trash, debris, litter cigarette butts, etc. This product is produced by StormTrap, LLC. (877) 867-6872.
- C. The MTD shall use the passive energy of the influent stream to drive the floatables into disposable nets or screening baskets at the specified velocities without velocity brake or other requirements at the mouth of the net or screening basket.
- D. External by-pass structures can be utilized with TrashTrap however external by-pass structures are not required.
- E. All flow is directed into the netting bag or screening basket. The netting bag or screening basket can hold sorption material to capture oil and grease. The oil sorption material contained in the netting bag can sorb oil sheen and grease. Oil sorption materials can also be located outside of the netting bag or screening device and secured to the TrashTrap structure. The net opening size determines the size of captured floatable trash and debris.
- F. Oil Storage is dependent upon selection of optional hydrocarbon accessories. Refer to the TrashTrap drawings for unit specific storage capacities.

1.2 RELATED SECTIONS

- A. Section XXXXX
- B. Section XXXXX
- C. Section XXXXX
- D. Section XXXXX

1.3 REFERENCES

- A. ASTM International (ASTM):
 - a. A-615/615M - Standard specification for deformed and plain billet-steel bars for concrete reinforcement

- b. C-857 - Standard practice for minimum structural design loading for underground precast concrete utility structures
 - c. C-858 - Standard specification for underground precast concrete utility structures
 - d. C-891 - Standard practice for installation of underground precast concrete utility structures
 - e. C-990 - Standard specification for joints for concrete pipe, manholes, and precast box sections using preformed flexible joint sealants
 - f. D-3776 – Standard test method for mass per unit area (weight) of fabric
 - g. D-3884 – Standard guide for abrasion resistance of textile fabrics (rotary platform, double-head method)
 - h. D-5034 – Standard test method for breaking strength and elongation of textile fabrics
 - i. D-6797 – Standard test method for bursting strength of fabrics constant-rate-of-extension (CRE) ball burst
- B. American Concrete Institute (ACI):
- a. 318 - Building code requirements for structural concrete
- C. Federal Specifications (FS):
- a. FS-SS-S-210 - Sealing Compound, Preformed Plastic for Expansion Joints and Pipe Joints

1.4 DESIGN REQUIREMENTS

- A. Precast concrete modular storm water detention: ASTM C 858
- B. Minimum Structural Design Loading: ASTM C 857.
 - a. Total Cover:
 - i. Minimum: As indicated on the Drawings.
 - ii. Maximum: As indicated on the Drawings.
 - b. Concrete chamber shall be designed for AASHTO HS-20 wheel load and applicable impact.
 - c. Minimum Soil Pressure:
 - i. As indicated on the Drawings.
 - d. Vertical and lateral soil pressures shall be determined using:
 - i. Groundwater: At or below invert of system.
 - ii. Soil density is assumed to be 120 pcf.
- C. The MTD shall be designed to cover the entire open cross-sectional area of the outfall pipe and be able to transmit the peak flow through the pipe with a maximum head loss of no more than 4 inches.

1.5 SUBMITTALS

- A. Comply with Section 01330 (01 33 00) - Submittal Procedures, with the exception that shop drawings shall be 11 inches by 17 inches.
- B. Product Data: Submit manufacturer's product data and installation instructions.
- C. Shop Drawings:
 - a. Submit manufacturer's shop drawings, including plans, elevations, sections, and details, indicating layout, dimensions, foundation, cover, and joints.
 - b. Indicate size and location of access openings and inlet and outlet pipe openings.
 - c. Indicate sealing of joints.
- D. Certification by a Professional Engineer licensed in the state of installation shall be submitted that the MTD meets or exceeds the structural design standards listed in this specification and local codes.

1.6 DELIVERY, STORAGE, AND HANDLING

- A. Delivery of Accessories: Deliver to site in manufacturer's original, unopened containers and packaging, with labels clearly identifying product name and manufacturer.
- B. Storage of Accessories:
 - a. Store in accordance with manufacturer's instructions.
- C. Handling: Protect materials during handling and installation to prevent damage.
 - a. Contractor to provide an adequate number of skilled workmen who are thoroughly trained and experienced in the necessary crafts and who are completely familiar with the specified requirements and the methods needed for proper performance of the work.
 - b. Contractor to provide adequate equipment in size, capacity, and numbers to accomplish the work in a timely manner.

PART 2- PRODUCTS

2.1 MANUFACTURER

- A. StormTrap, 1287 Windham Parkway, Romeoville, IL 60446. Phone (815) 941-4663. Fax (331) 318-5347. Website www.stormtrap.com.
- B. The Contractor shall specify the supplier to be used at the time of bid in accordance with the bidding form. No substitution of supplier of the MTD shall be allowed after the bid opening. "Or equal" statements on this form will be cause for rejection of the bid.
 - a. In the event that the Contractor elects to specify and install a MTD from a manufacturer that does not meet the minimum experience requirements specified in Section 2.2 of this specification, then the Contractor shall provide a performance bond or cash deposit equal to 100% of the MTD cost with the bid. This performance bond or cash deposit shall be in effect for one year from the date the system is placed in operation and accepted by the customer.
 - b. During the term of the bond, the Contractor shall repair, modify or replace the equipment in a manner acceptable to the owner if, in the opinion of the owner, the operation of the MTD is unsatisfactory. Normal wear or malfunctions caused

by neglect or abuse will not be considered justifiable reasons for unsatisfactory operation.

- c. In the event that the owner determines that the operation of the system is unsatisfactory during the term of the bond, and the Contractor does not correct the deficiencies within six (6) months from the date the Contractor is notified in writing that such deficiencies exist, the Owner may make the necessary repair, modification or replacement to the system and deduct the costs of such from the bond or deposit of the Contractor.

2.2 QUALITY ASSURANCE

- A. The netting floatables collection system shall be a product of an established firm experienced and qualified in the manufacture and design of such systems and who can demonstrate adequate installation and performance of similar systems elsewhere. An established supplier or firm must:
 - a. Be designed by a licensed Professional Engineer licensed in the state of the installation with appropriate professional liability insurance. Proof of insurance of the Professional Engineer must be provided with Submittals.
 - b. Have a minimum of five (5) years' experience in the manufacture/design of such systems;
 - c. Have undertaken physical modeling hydraulic studies to substantiate head loss requirements and have documented test results available for review by the engineer or owner;
 - d. Have a minimum of ten (10) floatables collection systems in service for a minimum of 2 years with satisfactory performance. For each installation, the Contractor shall provide:
 - i. Location and owner,
 - ii. Installation date,
 - iii. Contact person and telephone number,
 - iv. Model number of the system or the capacity.
- B. All fabricated materials shall be of the highest quality, free of structural, handling, and workmanship defects.
- C. The entire system shall be designed and manufactured to have a minimum life cycle of 25 years.

2.3 MATERIALS AND DESIGN

- A. Precast concrete stormwater modules:
 - a. Size: As indicated on the drawings
 - b. Concrete:
 - i. Minimum compressive strength: 6,000 psi at 28 days
 - ii. Entrained air content: 5 to 8 percent

- c. Reinforcing bars: ASTM A 615, Grade 60
 - d. Cover for reinforcing bars: ACI 318
 - B. Concrete accessories:
 - a. Joint Tape:
 - i. ASTM C 990
 - ii. 7/8-inch diameter, preformed mastic joint sealer
 - iii. Approved by manufacturer
 - b. Joint Wrap:
 - i. 8-inch wide sealant with protective release paper
 - ii. Approved by manufacturer
 - C. Access openings:
 - a. Size: As indicated on the drawings
 - i. Hatches intended for net maintenance shall have a minimum clear opening as specified on the drawings. The minimum clear opening shall be the width of the net frame plus 6-inches or more.
 - ii. Hatches shall be provided with a lockable latch and lift springs or cylinders and prop up mechanism to hold the hatch doors in opened position
 - iii. Circular manhole covers shall be bolt down lids
 - b. Size and locations approved by manufacturer
 - c. Manhole steps shall be installed as shown on the drawings and in conformance with OSHA requirements.
 - D. Pipe openings:
 - a. Size: As indicated on the drawings
 - i. Pipe openings shall maintain a minimum of 1'-0" clearance from a vertical edge of the TrashTrap modules
 - b. Size and locations approved by manufacturer
 - E. Disposable nets and net support frames:
 - a. The disposable nets and net support frames shall be of adequate size and shape to withstand anticipated hydraulic and other loads specified and not restrict the ease of removal and replacement of the nets within the MTD.
 - b. Disposable nets shall be constructed of a knotless knitted mesh synthetic material with openings as indicated on the drawings and mounted on a one piece molded plastic tapered frame. The net and frame shall be sized to permit rapid installation and removal from the MTD without contact with the floatables captured in the net. Systems that use hooks to attach the disposable mesh nets to the frame or require the use of a lifting cassette are acceptable.
 - c. The net frame shall be constructed of wood or a single piece molded from high density polyethylene plastic with lifting holes formed into the tapered frame. The net frame shall be a sized as indicated on the drawings.

- d. The mesh net material shall be secured to the net frame in a manner that exceeds the yield strength of the mesh material.
- e. The composition, denier, and the method of knitting of the mesh material shall be such that the finished mesh material has a minimum tensile strength of 250 pounds and a minimum elongation of 100% in the direction of the fabric wales and a minimum tensile strength of 220 pounds and a minimum elongation of 100% in the direction of the fabric courses. The tensile strength shall be determined by an independent accredited testing laboratory of the American Association for Laboratory Accreditation using ASTM Test Procedure D-5034 using an Instron® Testing Machine. The testing laboratory must be accredited for technical competence in the field of mechanical testing and be certified to perform tensile and strength tests. The supplier of the disposable nets shall provide certified copies of these test results at the request of the engineer.
- f. The composition denier, and the method of knitting of the mesh material shall be such that the finished mesh material has a minimum burst strength of 250 pounds. The burst strength shall be determined by an independent accredited testing laboratory of the American Association for Laboratory Accreditation using ASTM test procedure D-6797 on a ball bursting system strength testing machine. The testing laboratory must be accredited for technical competence in the field of mechanical testing and be certified to perform burst strength tests. The supplier of the disposable nets shall provide certified copies of these test results at the request of the engineer.
- g. The composition, denier, and the method of knitting of the mesh material shall be such that the finished mesh material shall have a minimum abrasion resistance of 40 cycles. The abrasion resistance shall be determined by an independent accredited testing laboratory of the American Association for Laboratory Accreditation using ASTM test procedure D-3884 on a Taber abrasion testing machine with H18 wheels as the abradant and 1000 grams/wheel load. The testing laboratory must be accredited for technical competence in the field of mechanical testing and be certified to perform abrasion tests. The supplier of the disposable nets shall provide certified copies of these test results at the request of the engineer.
- h. The composition, denier, and the method of knitting of the mesh material shall be such that the finished mesh material shall have a weight of at least 11.5 ounces per square yard. The weight shall be determined by an independent accredited testing laboratory of the American Association for Laboratory Accreditation using ASTM test procedure D-3776, option C. The testing laboratory must be accredited for technical competence in the field of mechanical testing. The supplier of the disposable nets shall provide certified copies of these test results at the request of the engineer.

- i. The seams of the net shall be formed by rolling and stitching in a manner that produces a burst strength of at least that of the material itself as measured using ASTM test method D-6797 as performed on a ball bursting system strength testing machine. The supplier of the disposable nets shall provide certified copies of these test results at the request of the engineer.
 - j. The material shall be stable over the temperature range of -20 to +115 degrees Fahrenheit without melting, deforming or otherwise suffering loss of the mechanical and chemical properties contained in this specification.
 - k. The material shall be unaffected by chemical pH from 4.5 to 7.5 as determined using the American Association of Textiles Chemists and Colorists pH Test Procedure.
- F. LiftMaster lifting units**
- a. The LiftMaster lifting units shall be constructed of materials of adequate size and type to withstand anticipated loads per the structural calculations.
 - b. The LiftMaster lifting units shall be of adequate size and shape to withstand anticipated hydraulic and other loads specified and not restrict the ease of removal and replacement of the nets within the MTD.
 - c. The net and its frame shall fit into the LiftMaster lifting units in a manner that minimizes the possibility of the net material being cut or abraded by contact with the LiftMaster frame.
 - d. The LiftMaster lifting unit that holds the disposable mesh nets and support frame shall be equipped with hold down devices that prevent the nets from floating up out of the lifting LiftMaster when the device is surcharged.
 - e. The design of the device shall allow for the removal of the nets without removing the LiftMaster lifting unit from the system. Products that do not allow this operating and maintenance flexibility are not acceptable.
- G. Bypass grating, and sluice gates**
- a. The bypass grating and sluice gates shall be constructed of materials of adequate size and type to withstand anticipated loads per the structural calculations.
 - b. The bypass grating and sluice gates shall be of adequate size and shape to withstand anticipated hydraulic and other loads specified and not restrict the ease of removal of trash and debris contained within the MTD.
 - c. The bypass grating shall be constructed of materials of adequate size and type to withstand anticipated loading with a minimum deflection of ¼ inch or less under a uniform live load of 100 pounds and a deflection of ¼ or less under a concentrated live load of 300 pounds applied at mid span.
 - d. The net support frame can be equipped with removable sluice gates that when inserted into the frame blocks the entire opening of the frame and does not allow trash or floatables to escape during the change out operation. The sluice gate shall slide into place from the surface and be easily installed and removed.

- e. The LiftMaster support frame can be equipped with removable sluice gates that are inserted in place in front of the nets prior to removing the lifting LiftMaster and changing the disposable nets. The sluice gates shall prevent the escape of floatables during the net change out procedure and have self-cleaning edges when inserted in the guides.
- H. Screening baskets
- a. The screening baskets shall be constructed of materials of adequate size and type to withstand anticipated loads per the structural calculations
 - b. The screening baskets shall be of adequate size and shape to withstand anticipated hydraulic and other loads specified and not restrict the ease of removal of trash and debris contained within the MTD.
 - c. The opening size of the screening baskets shall be sized as indicated on the drawings
- I. Mounting and support system, guide rails, and support members:
- a. The mounting support system, guide rails, and support members shall be constructed of materials of adequate size and type to withstand anticipated loads per the structural calculations.
 - b. The mounting support system, guide rails, and support members shall be of adequate size and shape to withstand anticipated hydraulic and other loads specified and not restrict the ease of removal of trash and debris contained within the MTD.
 - c. The mounting and support system, guide rails, and drain screen shall be installed in the concrete channel surfaces, horizontal and vertical as designed using bolts, nuts, and washers of adequate size and numbers to withstand the anticipated loads.
 - i. All mounting will be “drill-in” type anchors and drilled into the sidewalls and floor of the containment chamber.
 - ii. The mounting system will be designed for the impact by the peak flow rate.
 - d. If not factory assembled, the manufacturer shall supply all necessary hardware required to install the mounting and support system to the concrete housing. This hardware shall be of the same materials of construction as the mounting and support system.
 - e. For systems with pipe inverts more than 12 feet below grade, guide rails and LiftMaster shall be included in the system. The guide rails shall allow the LiftMaster to be easily removed and re-installed from the surface. The guide rails shall extend from the top of the net support frame to the top of the inside of the precast chamber and are securely fastened to the precast chamber.

- f. The mounting and support system area shall be kept to a minimum and shall direct flow into the open mouth of the nets or screening baskets to the maximum extent practical.
 - g. Calculations to document that the design meets the bid requirements shall be provided by the CONTRACTOR with the Submittals.
 - J. Netting accessories (Optional):
 - a. Sizing: Sorbent booms shall be placed in the device for the absorption of gasoline; diesel fuel, lube oil, jet fuel, transformer oils, chlorinated solvents, aromatic solvents, hydraulic oils, light crude.
 - b. The sorbent boom or Rubberizer® boom shall be manufactured by Haz-Mat Response Technologies Inc. or approved equal.
 - c. Refer to sorbent boom manufacturer for specific product details

2.4 PERFORMANCE

- A. The MTD shall use a disposable nets or screening baskets of the same height, width and length positioned as shown on the drawings. The active capacity of the installed nets or baskets shall be sufficient to handle the peak flows specified the drawings. The mounting and support system area shall be kept to a minimum and shall direct flow into the open mouth of the nets or baskets to the maximum extent practical.
- B. The MTD shall cover the entire open cross-sectional area of the outfall pipe and be able to transmit the peak flow through the pipe with a maximum head loss of no more than 4 inches.
- C. The hydraulic design of the MTD shall include the mounting and support system as an integral unit. The approved MTD supplier shall be responsible for this design and shall submit calculations by a Professional Engineer licensed in the state of the installation, along with required submittals which meet the design requirements included in this specification.
- D. The design flows stated in the specifications are for the entire facility which includes both the netting bags or screening baskets in addition to the screens. The facilities are to be designed to pass these flows by use of the sum of the open or effective area obtained from both the netting bags or screening baskets and the bar screens in each facility. The netting or screening basket equipment shall be constructed to withstand velocities of up to 5 feet per second. This is not to be misinterpreted that the netting or basket equipment is required to pass all of the specified flows since it is the combination of the netting or basket equipment and the bar screens that are designed to pass these specified flows. The dimensions specified for both the bar screens and openings for the netting or baskets are critical and shall be maintained.
- E. The inlet pipe shall discharge the stormwater into the net or basket cavity. Gross pollutants and particles larger than the net or screen opening enter the net or basket cavity where they are captured prior to the stormwater exiting the device.

- F. The particles that shall be removed are all particles 5 mm or greater for all projects located in the state of California.
- G. Capacities:
 - a. Water quality flow __ CFS
 - b. Peak flow __ CFS
 - c. Peak velocity __ Ft/Sec
 - d. Hydrocarbon capacity __ Gallons (If utilized)
 - e. Trash/Debris capacity __ Ft³.
 - f. Net/Screen Opening size 4.7 mm (For all projects located in CA)
- H. It shall be the responsibility of the supplier of the MTD to insure satisfactory operation of the total MTD as a complete, workable installation that meets the performance and materials specifications of this contract.

PART 3-INSTALLATION

3.1 EXAMINATION

- A. Examine area to receive the manufactured treatment device. Notify the engineer and manufacturer if area is not acceptable. Do not begin installation until unacceptable conditions have been corrected.
- B. Verify in field before installation, dimensions and soil conditions, including but not limited to groundwater and soil bearing capacity.
- C. Coordinate with other trades as required to assure proper and adequate provision in the work of those trades for interface with the work described in this section.

3.2 METALLIC COMPONENTS FABRICATION

- A. Fabrication of the TrashTrap device shall be in strict accordance with the design indicated on the submittal drawings.
- B. If field installation is applicable, the MTD shall be provided with mounting brackets and mounting anchors. Refer to installation guide for more detailed installation guidelines and procedures.
- C. Set work accurately into position as indicated on the submittal drawings. Ensure the components are plumb, level and true.
- D. Components shall be installed in accordance with the manufacturer's instructions per the submittal drawings.

3.3 PRECAST MODULAR STORMWATER STRUCTURES

- A. Stormwater modules shall be manufactured according to shop drawings approved by the installing contractor and engineer. The shop drawings shall indicate size and location of roof openings and pipe openings.
- B. Excavation shall be as specified in Section 02300 (31 00 00)

- C.** Modules shall be installed in accordance with manufacturer's instructions and ASTM C 891-09, standard practice for installation of underground pre-cast concrete utility structures. The following additions and/or exceptions shall apply:
- a.** Specifications on the engineer's drawings shall take precedence
 - b.** Modules shall be placed on a level pad of 3/4" aggregate that extends 2'-0" past the outside of the system, per ASTM C891-09
 - c.** Modules shall be placed such that the maximum space between adjacent modules does not exceed 3/4". If the space exceeds 3/4", the modules shall be reset with appropriate adjustment made to line and grade to bring the space into specification
 - d.** The perimeter horizontal joint of the modules shall be sealed with preformed mastic joint sealer according to ASTM C891-09, 8.8 and 8.12.
 - e.** All exterior joints between adjacent modules shall be sealed with pre-formed, cold-applied, self-adhering elastomeric resin bonded to a woven highly puncture resistant polymer wrap conforming to ASTM C891-09 and shall be 0'-8" wide with integrated primer sealant as approved by manufacturer. The adhesive exterior joint wrap shall be installed according to the following installation instructions:
 - i.** Use a brush or wet cloth to thoroughly clean the outside surface at the point where the joint wrap is to be applied
 - ii.** A release paper protects the adhesive side of the joint wrap. Place adhesive tape (Butyl side down) around the structure, removing the release paper as you go. Press the joint wrap firmly against the module surface when applying.
- D.** Modules shall be backfilled in accordance with manufacturer's instructions and ASTM C 891-09, standard practice for installation of underground pre-cast concrete utility structures. The following additions and/or exceptions shall apply:
- a.** The fill placed around the device must be deposited on both sides at the same time and to approximately the same elevation. At no time shall the fill behind one side wall be more than 2'-0" higher than the fill on the opposite side.
 - b.** Backfill shall be compacted to 95% standard proctor density or otherwise specified by engineer.
 - c.** Care shall be taken to prevent any wedging action against the structure, and all slopes bounding or within the area to be backfilled must be stepped or serrated to prevent wedge action.
 - d.** Care shall also be taken as not to disrupt the joint wrap from the joint during the backfill process.
 - e.** Backfill material shall be clean, crushed, angular No.5 (AASHTO M43) aggregate.
- E.** Align the center of pipe to correct elevation and insert into opening. The annular space between the pipe and the opening shall be filled with non-shrink grout.

- F. Use precast adjusting rings as needed to meet grade. For cover over 2'-0" it is recommended to use a precast barrel or cone section.
- G. The contractor is responsible to ensure the selected water tight solution performs as specified by the manufacturer.
- H. Do not use modules that are damaged, as determined by manufacturer.

3.4 MANUFACTURER INSTALLATION TECHNICAL ASSISTANCE

- A. At the time and place of installation of any TrashTrap®, StormTrap, LLC. will provide a Product Liaison on site to offer installation advice to the installation contractor if reasonable notification (approximately two-week notice) of the install date is given.

3.5 OPERATION AND MAINTENANCE

- A. The maintenance of the TrashTrap® is the responsibility of the Owner. Each site has unique site conditions. It is the responsibility of the Owner to establish a schedule according to the conditions of the specific TrashTrap location. Failure maintain the device can lead to reduced flow capacity and blockage due to collected pollutants. It is strongly recommended that the Owner follow the prescribe maintenance specifications and procedures published by StormTrap, LLC.

End of Section

Appendix C - Installation Manual and Installation Photographs

TrashTrap Installation Guide/Pre-Construction Form

Recommended Tools to Have Onsite

- Adjustable 4-way chains or slings and/or swivel appropriately sized for lifting components
- Clevis/clutches (x4) to connect lifting chains/slugs to lifting hardware (provided) or utility hooks
- Utility hooks (x4) needed for placement of internal plate components
- Manhole ladder
- Hammer drill with 1/2" concrete bit to anchor internal plate components to concrete vault
- Drill with 1/4" bit to connect net support frame to internal plate components
- Impact drill with 1/2" extended socket for concrete wedge anchors
- Hammer 2lb. for concrete wedge anchors
- Caulk gun
- Proper PPE protection (i.e. gloves when handling aluminum components)

Installation Procedure

1. Preconstruction Meeting

- Prior to delivery, the installing contractor is responsible to arrange with StormTrap a preconstruction site meeting. It is recommended that all involved parties participate in the meeting. It is also recommended that the preconstruction meeting be completed prior to preparation of the subbase. Any installation questions/concerns as well as shipping logistics/sequencing should be discussed and determined at this time. The objective of the preconstruction meeting is as follows:
 - i. Determine an acceptable delivery time and date as well as provide StormTrap with any specific delivery instructions
 - ii. Verify that the equipment used to set/install the system is adequate. It is the responsibility of the installing contractor to ensure the equipment is adequate. StormTrap will provide the necessary information regarding weight and size of the components in order to assist the contractor to make an informed decision.
 - iii. Review this document with the contractor and address any questions/concerns prior to the components arriving onsite.

2. Site Preparation Excavation

- In addition to the overall system dimensions, the sub base of the system will extend beyond the dimensions of the TrashTrap system. Refer to the approved TrashTrap drawings for sub base requirements and system dimensions.

3. Site Preparation Foundation

- TrashTrap modules shall be placed on a foundation as detailed in the approved drawings.
- TrashTrap modules shall be placed on a bed of clean, crushed, angular stone as detailed in the approved drawings.
- Both the aggregate and geogrid (if required) shall be installed with a minimum 2'-0" overhand beyond the limits of the TrashTrap system (refer to

TrashTrap approval drawings for depth of subgrade and specifications as subbase preparation can vary from project to project).

- Refer to the approved TrashTrap drawings for the required minimum soil pressure.
- Soil strengths are to be verified in the field by others.

4. Delivery

- StormTrap will do everything possible to maintain trucking schedule, however, StormTrap is not responsible for trucks that are late due to Acts of God (traffic, weather, etc). Therefore, StormTrap cannot guarantee load times
- A \$65.00 per hour detention fee will be charged for any trucks being held on site longer than an hour past their scheduled delivery time.
- If the contractor needs to cancel any shipments, they must do so 72 hours prior to their scheduled arrival at the job site. If canceled after that time a partial or full load of freight will be charged to the installing contractor). Please contact your account representative or StormTrap at 815-941-4663.
- BEFORE removing any units from the flatbeds, the contractor is responsible to inspect and verify that the units have arrived in an undamaged state. StormTrap will not accept any backcharges or returns for the product once it is removed from the mode of transportation.
 - i. If the TrashTrap components are damaged StormTrap, LLC must be contacted immediately to assess the damage and to determine whether or not the components will need to be replaced.
 - ii. If any unit arrives at the job site damaged do not unload it; contact StormTrap immediately. Any damage not reported before the truck is unloaded will be the contractor's responsibility. Photos should be emailed and documented.
- TrashTrap units cannot be altered in any way after manufacturing without written consent from StormTrap, LLC.

5. Lifting

- All the precast units are supplied with cast-in lifting anchors to enable safe handling. To prevent stress and possible concrete cracking, all units must be handled using the cast-in lifting anchors and associated lifting clutches. Installers should use approved lifting equipment only. It is the installing contractor's responsibility to ensure the lifting clutches are available on site. The lifting points of anchors are clearly shown on the StormTrap drawings.
- Wherever possible, all components should be lifted from the delivery truck and set directly onto the prepared subgrade or into its final location. If temporary storage of the components is required onsite, they should be placed carefully on level, even ground. Modules should not be stacked on top of each other.
- Take care not to strike the modules or components together when unloading or lowering occurs. Be aware of pinch hazard at all times and don't walk or work under suspended loads.

6. Sequencing of Offloading and Installation

- The components should be offloaded in the following order:
 - i. Remove the internal metallic components from the precast base module and set to the side (if applicable)

- ii. Offload and set the precast base module (if applicable)
- iii. Reconnect to the internal metallic components and place in the base module or in the final location
- iv. Offload and set the precast top module (if applicable)
- v. Connect internal metallic components to the top module or into the final location using supplied anchors
- vi. Connect net frame using supplied anchors, nuts, bolts, and washers

7. Backfill Procedure (For Inline TrashTrap Applications)

- The remaining backfill placed around the perimeter of the TrashTrap units must be deposited on both sides at the same time and to approximately the same elevation. At no time shall the fill behind one sidewall be more than 2'-0" higher than the fill on the opposite side. Backfill shall be compacted to 95% standard proctor density or otherwise specified by the engineer or approved TrashTrap drawings. Care shall be taken to prevent any wedging action against the structure, if shoring is not utilized, all slopes bounding or within the area to be backfilled must be stepped or serrated to prevent wedge action. Recommended backfill to consist of ¾" coarse aggregate stone or approved equal and shall conform to the specified density/lateral saturated pressure requirements specified on the approved drawings.
- Top or fill material can consist of a variety of materials including but not limited to stone, clay, ¾" with or without fines and not to exceed the specified backfill density requirements
- When compaction is to be completed overtop the TrashTrap system, vibratory action shall be disengaged at all times. Equipment above the system shall not exceed the minimum loading requirements shown in the approved TrashTrap drawings.
- After the minimum required amount of cover is placed over top of the system, the standard designed loads can be utilized over the system.

8. Contact Information

- StormTrap PM Name
- StormTrap PM Phone Number
- StormTrap PM Email Address

Appendix D – TrashTrap Operations and Maintenance Manual

TrashTrap® Manufacturer’s Instruction Manual

Regular inspections are recommended to ensure that the system is functioning as designed. Please contact your Authorized TrashTrap Representative if you have questions regarding the inspection and maintenance of the TrashTrap system. TrashTrap does not require entry into the system for maintenance; however, it is prudent to note that prior to entry into any underground storm sewer or underground structure, appropriate OSHA and local safety regulations and guidelines should be followed.

Inspection Scheduling

The frequency of inspections and maintenance is dependent on site specific loading conditions and rainfall frequency. Within the first year of operation, it is recommended that the unit be inspected quarterly to determine the rate of pollutant accumulation in order to develop a more accurate maintenance schedule. TrashTrap systems are recommended for inspection whenever the upstream and downstream catch basins and stormwater pipes of the stormwater collection system are inspected or maintained. This will minimize the cost of the inspection if it is done at the same time. If checked on an annual basis, the inspection should be conducted before the stormwater season begins to ensure that the system is functioning properly for the upcoming storm season.

Inspection Process

Inspections should be done such that a sufficient time has lapsed since the most recent rain event to allow for a static water condition. Visually inspect the system at all manhole and access opening locations. For debris accumulation, visually inspect the netting or screening basket components to determine the bag or basket capacity. Nets or baskets containing only

minor quantities of debris may be retained in place. It is recommended to replace the nets or clean the screening baskets when they appear 1/2 - 2/3 full. Failure to replace nets and/or remove floatables from bypass screening (if applicable) will lead to hydraulic relief, drain down deficiencies, and decrease the long-term functionality of the system.

Finally, inspect the inlet to ensure that the silt level or any foreign objects are not blocking the device.

TrashTrap units can also be installed with remote monitoring technology that measures the current capacity of trash and debris contained within the system and reports the data to any internet device to decrease the amount of physical inspections required. If a remote monitoring device is used, proper maintenance of the device, such as replacement of batteries, cleaning sensor, etc. needs to be completed to ensure functionality of the remote monitoring technology.

Maintenance Process – Debris Removal

Maintenance should be done utilizing proper personal protective equipment such as: safety glasses, hard-hat, gloves, first aid kit, etc. Maintenance should occur only when a sufficient time has lapsed since the most recent rain event to allow for a static water condition for the duration of the maintenance process.

In the case that a netting configuration or a removable screening basket is utilized, a vacuum truck is not required. However, a vacuum truck is required if a fixed screening basket configuration is utilized.

Maintenance Process – Debris Removal for Netting Configurations

For floatable debris removal when a netting bag is utilized, lift the netting bag by the frame, moving it upwards along the netting support frame. To ease lifting the nets to the surface, gaff hooks or a service vehicle (crane/hoist/boom truck) may be used. Slowly raise the

netting frame allowing water in the net to drain as it is raised to allow it to drip dry. Once the netting component is fully removed from the system, it should be properly disposed of per local, state, and federal guidelines and regulations. Typically, the netting component can be disposed of in a common dumpster receptacle.



Maintenance Process – Debris Removal for Removable Basket Configurations

For floating debris removal when a removable basket is utilized, remove the screening basket by lifting the basket slowly moving it upwards along the support frame. Once the screening basket is fully removed from the TrashTrap system, empty the basket into a dumpster receptacle by either tipping the unit so the debris falls out the mouth of the basket or release the bottom latch in the basket. The latch opens the bottom section of the basket to drop debris into the receptacle. After the basket has been emptied, ensure that all latches are secured prior to placing the basket back into the TrashTrap system. Place the basket back into the TrashTrap system by sliding the netting frame down the support frame.

Removable basket configurations can also be maintained without removing the screening basket from the TrashTrap. If electing to perform maintenance without removing the basket, see the maintenance process for debris removal for fixed basket configurations below.

Maintenance Process – Debris Removal for Fixed Basket Configurations

For floatable debris removal when a fixed basket is utilized, a vacuum truck, or similar trailer mounted equipment can be used to remove the debris. Unlatch the top section of the screening basket and lift to access the inside of the basket. Take the vacuum hose and remove all debris from inside of the basket. After the basket has been emptied, ensure that the top section of the screening basket is closed, and all latches are secured.

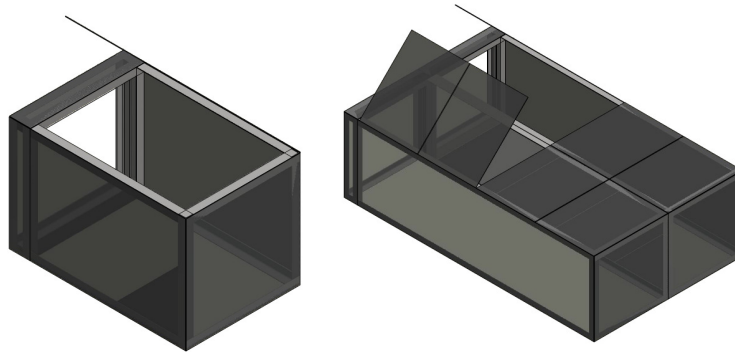

Maintenance Process – Net Replacement

Install a new net assembly by sliding the netting frame down the support frame and ensure the netting lays over the plate assembly such that the netting is not restricted. To order additional disposable nets, contact your local TrashTrap representative. New nets come with tie wraps temporarily holding the net material to the frame component for easy handling and storage. It is not recommended to remove the tie wraps until the net is ready to be installed. The frame is tapered from top (widest part) to bottom and is also tapered from front (towards the sewer) to back. Cut the tie wraps that secures the netting material to the frame for shipment and lower the net down the guide rails. If debris has accumulated in the net support frame, remove the objects so the new net seats fully in the channel when installed.

When lowering the net, the following details should be exercised when placing the net:

- Watch the lowering to make sure that there are no unexpected entanglements.

- Be careful not to let the toe of the net get caught under the frame when it reaches the bottom of the support frame. This is typically accomplished by holding the toe of the net until after the net has started to prop into place.
- Ensure the netting lays over the plate assembly such that the netting is not restricted.



Maintenance Process – Clean Up, Disposal, and Documentation

Complete a post maintenance inspection to ensure that all components have been replaced and are properly secured within the TrashTrap device. It is a good practice to take time stamped photographs after every maintenance event to include within maintenance logs. After verifying all components, secure the access openings and ensure proper disposal of all pollutants removed during maintenance per local, state, and federal guidelines.

Proof of inspections and maintenance is the responsibility of the owner. All inspection reports and data should be kept on site or at a location where they will be accessible for years in the future. Some municipalities require these inspection and cleaning reports to be forwarded to the proper governmental permitting agency on an annual basis. Refer to your local and national regulations for any additional maintenance requirements and schedules not contained herein. Inspections should be a part of the standard operating procedure. It is good practice to keep records of rainfall events between maintenance events and the weight of material removed, even if no report is required.

Appendix E – TrashTrap Warranty

TRASHTRAP® WARRANTY

8.1 Warranty Statements

1. StormTrap LLC warrants to the Purchaser that the TrashTrap® modules, when installed strictly in accordance with StormTrap LLC's written installation instructions, are of the quality set forth in the specifications published by StormTrap LLC for such module for a warranty period of 5 years. The warranty period shall commence starting the last day of installation of any module.
2. StormTrap LLC further warrants to the Purchaser that the products to be delivered hereunder shall be free of defects in materials and workmanship in normal use and service for a warranty period of 5 years.

8.2 Limits to Warranty

1. This is a Limited Warranty that applies solely to TrashTrap® modules and is exclusive and in lieu of all other warranties (whether expressed, implied, or statutory). **EXCEPT AS SET FORTH IN THE WARRANTY STATEMENTS, STORMTRAP LLC MAKES NO EXPRESS OR IMPLIED WARRANTY THAT THE PRODUCTS SOLD HEREUNDER ARE OF MERCHANTABLE QUALITY, ARE FIT FOR ANY PARTICULAR PURPOSE, COMPLY WITH REQUIREMENTS OF ANY SAFETY CODE OR COMPLY WITH THE LAWS AND REGULATIONS OF ANY STATE, MUNICIPALITY OR OTHER JURISDICTION.**

8.3 Limits to Beneficiaries and Damages and Claims

1. This limited warranty is given only to the Purchaser. It may not be assigned to any party other than Purchaser and there are no third party beneficiaries to this limited warranty.

2. **IN NO EVENT SHALL STORMTRAP LLC BE LIABLE FOR SPECIAL, INDIRECT, ECONOMIC, INCIDENTAL, EXEMPLARY, PUNITIVE OR CONSEQUENTIAL DAMAGES, AND STORMTRAP LLC SHALL NOT BE LIABLE FOR PENALTIES OR LIQUIDATED DAMAGES, INCLUDING LOSS OF PRODUCTION AND PROFITS, LABOR AND MATERIALS, OVERHEAD COSTS, OR ANY LOSS OR EXPENSE INCURRED BY THE PURCHASER OR ANY THIRD PARTY.**
3. StormTrap LLC's obligation under this warranty shall not include any freight or transportation charges or costs of installation.
4. **STORMTRAP LLC'S TOTAL LIABILITY TO PURCHASER SHALL IN NO EVENT EXCEED THE PURCHASE PRICE OF THE TRASHTRAP® MODULES IN RESPECT TO WHICH ANY CLAIM UNDER THIS WARRANTY ARISES, OR FOR ANY AND ALL CLAIMS ARISING OUT OF ANY CAUSE WHATSOEVER, WHETHER BASED IN CONTRACT, NEGLIGENCE OR OTHER TORT STRICT LIABILITY OR OTHERWISE.**
5. **THIS LIMITED WARRANTY IS THE EXCLUSIVE REMEDY FOR PURCHASER WITH RESPECT TO THE TRASHTRAP® MODULES.**
StormTrap LLC not be liable to the Purchaser or to any third party for any other product liability claims; claims arising from design, shipment, or installation of the TrashTrap® modules, or the cost of other goods or services related to the purchase and installation of the TrashTrap® modules.

8.4 Limitations Due to Installation, Handling and Use

1. For this Limited Warranty to apply, the TrashTrap® modules must be installed in accordance with all conditions required by state and local codes; all other applicable laws and regulations; and StormTrap LLC's written installation instructions.
2. This warranty shall not apply to any TrashTrap® modules which have been subjected to damage from abuse or mishandling, or which have been repaired or modified by anyone other than StormTrap LLC.

2. Excluded from this limited warranty are damages due to alteration, accident, misuse, abuse or neglect; the TrashTrap® modules being subject to conditions which are not permitted by StormTrap LLC's design criteria or installation instructions; such as but not limited to failure to maintain the minimum cover or exceed the maximum cover to grade set forth in the design criteria or installation instructions; failure to install within tolerance and set true to line and grade as set forth in the specifications or installation instructions; the placement of improper bedding or backfill materials; improper installation, bedding, or backfill techniques; failure of the product due to improper application or improper sizing; or any other event not caused by StormTrap LLC.

8.5 No Other Expressed Warranty

1. Except as specified herein, no other expressed warranty is given and no affirmation on Seller's part or on the part of Seller's representatives or agents, by work or act, shall constitute a warranty.
2. No representative of StormTrap LLC has the authority to change this Limited Warranty in any manner or to extend this Limited Warranty, unless written confirmation is provided by an officer of StormTrap LLC.

8.6 Remedies

1. If a breach of this warranty shall become apparent to the purchaser, the purchaser has the responsibility to provide StormTrap LLC with prompt written notice of the alleged breach at StormTrap LLC's company headquarters. This notice shall be provided within 30 days of the discovery of the alleged defect and shall describe it in detail. **AS THE SOLE AND EXCLUSIVE REMEDY TO PURCHASER FOR SUCH BREACH, STORMTRAP LLC AGREES TO PROVIDE REPLACEMENT MODULES OR REPAIR THOSE MODULES DETERMINED BY STORMTRAP, LLC TO BE DEFECTIVE AND COVERED BY THIS LIMITED WARRANTY.** Removal and/or installation of the replacement modules is the responsibility of the purchaser and specifically excluded by StormTrap LLC.

Appendix F – MCVAC Verification Letter



One Capitol Mall, Suite 320 • Sacramento, CA 95814 • p: (916) 440-0826 • f: (916) 444-7462 • e: mvcac@mvcac.org

StormTrap, LLC
1287 Windham Parkway
Romeoville, IL 60446

May 31, 2022

Dear Mr. Fajman,

Thank you for the submission of the StormTrap TrashTrap Net and Fixed Basket End-of-Pipe Systems full trash capture device for review by the Mosquito and Vector Control Association of California pursuant to the SWRCB Trash Treatment Control Device Application Requirements. The Association has reviewed the conceptual drawings for the StormTrap TrashTrap Net and Fixed Basket End-of-Pipe Systems and verifies that provisions have been included in the design that allow for full visual access to all areas for presence of standing water, and when necessary, allows for treatments of mosquitoes.

While this verification letter confirms that inspection and treatment for the purpose of minimizing mosquito production should be possible with the StormTrap TrashTrap Net and Fixed Basket End-of-Pipe Systems as presented, it does not affect the local mosquito control agency's rights and remedies under the State Mosquito Abatement and Vector Control District Law. For example, if the installed device or the associated stormwater system infrastructure becomes a mosquito breeding source, it may be determined by a local mosquito control agency to be a public nuisance in accordance with California Health and Safety Code sections 2060-2067.

"Public nuisance" means any of the following:

1. Any property, excluding water, that has been artificially altered from its natural condition so that it now supports the development, attraction, or harborage of vectors. The presence of vectors in their developmental stages on a property is prima facie evidence that the property is a public nuisance.
2. Any water that is a breeding place for vectors. The presence of vectors in their developmental stages in the water is prima facie evidence that the water is a public nuisance.
3. Any activity that supports the development, attraction, or harborage of vectors, or that facilitates the introduction or spread of vectors. (Heal. & Saf. Code § 2002 (j).)

Declaration of a facility or property as a public nuisance may result in penalties as provided under the Health and Safety Code. Municipalities and the vendors they work with are encouraged to discuss the design, installation, and maintenance of stormwater trash capture devices with their local mosquito control agency to reduce the potential for disease transmission and public nuisance associated with mosquito production.

Sincerely,

Megan MacNee
MVCAC Executive Director